

Glary[®] Power Technology

A bright sun with rays shining over a mountain range with clouds.

High Performance Power Converters

1/2 Bricks 250W~800W

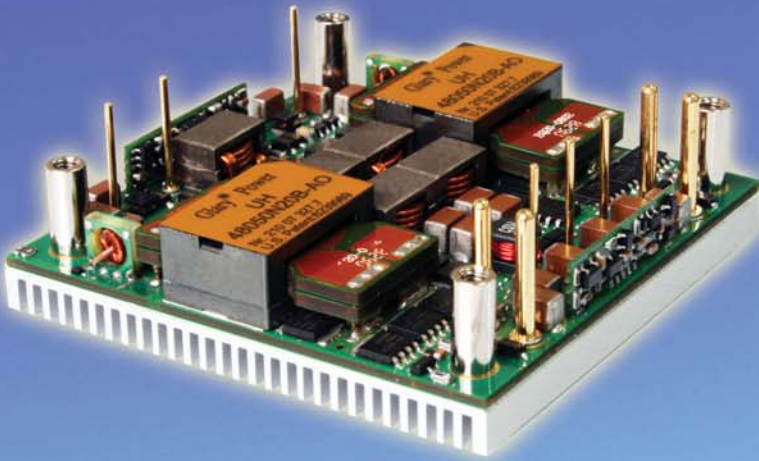

UH Series 1/2 Brick 800W /67A:

Input: 48V

Outputs: 12V, 28V and 48V

600W/120A :

Inputs: 24V and 48V

Outputs: 3.3V, 5V, 12V,
28V and 48V

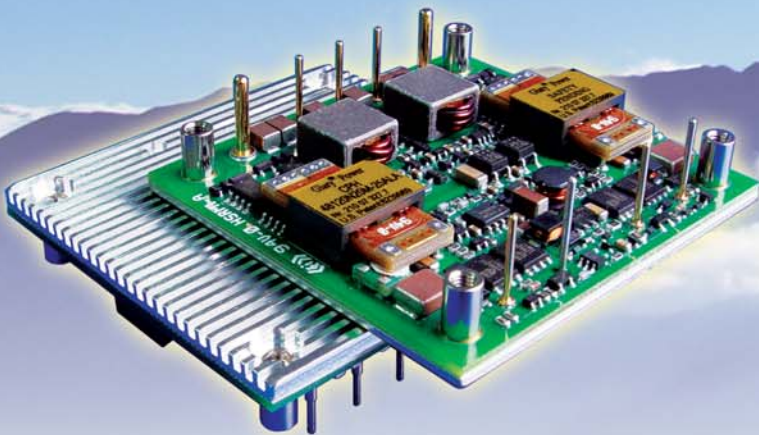

CPH and CBH 1/2 Brick 350W /100A:

Input: 24V and 48V

Outputs: 1.5V, 1.8V, 2.5V,
3.3V and 5V

250W/60A :

Inputs: 24V and 48V

Outputs: 1.5V, 1.8V, 2.5V,
3.3V and 5V

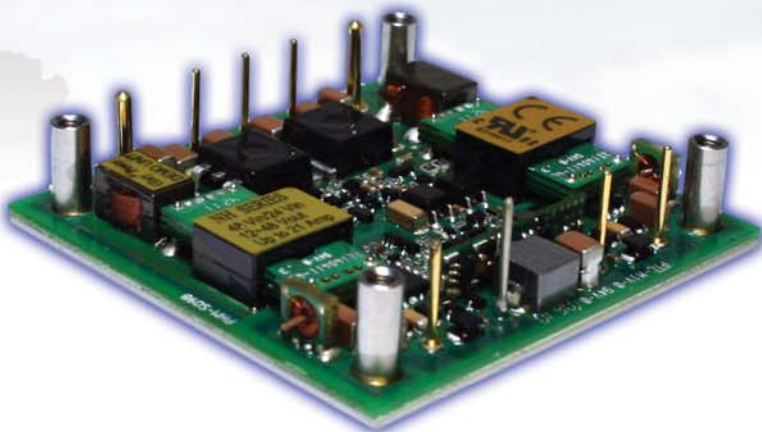

NH Series 1/2 Brick 336W /21A:

Input: 24V and 48V

Outputs: 12V, 24V, 28V and 48V

1/4 and 1/8 Bricks 130W~300W

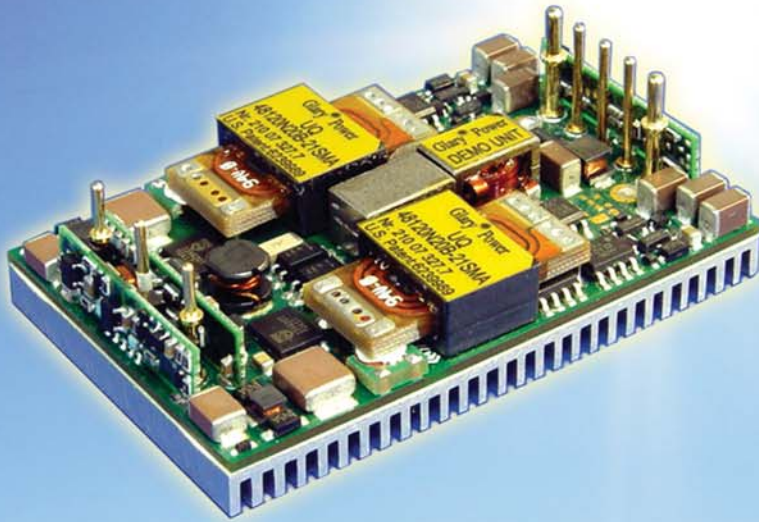

UQ Series 1/4 Brick 300W / 60A:

Inputs: 24V and 48V

Outputs: 3.3V, 5V, 7V and 12V

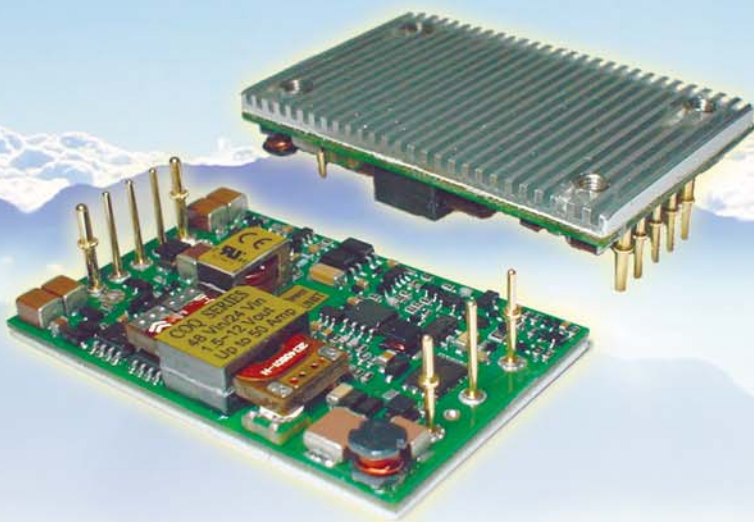

COQ Series 1/4 Brick 175W / 50A:

Inputs: 24V and 48V

Outputs: 1.5V, 1.8V, 2.5V, 3.3V,
5V, 7V and 12V

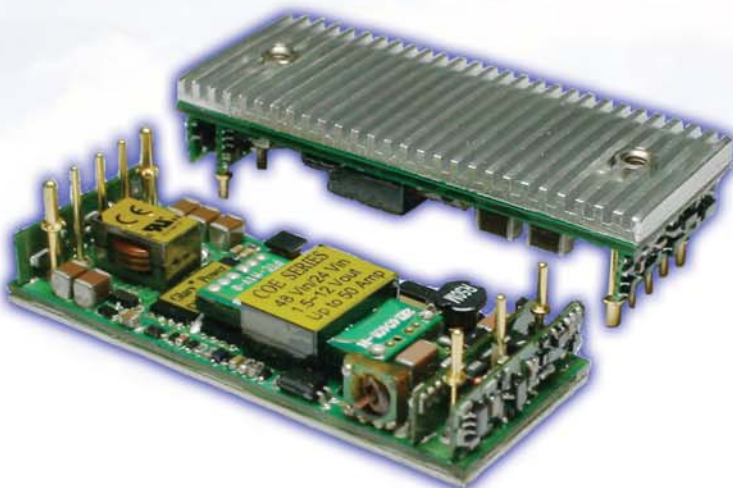

COE Series 1/8 Brick 132W / 50A:

Inputs: 24V and 48V

Outputs: 1.5V, 1.8V, 2.5V, 3.3V,
5V, 7V and 12V

1/16 and Micro Bricks 40W~50W

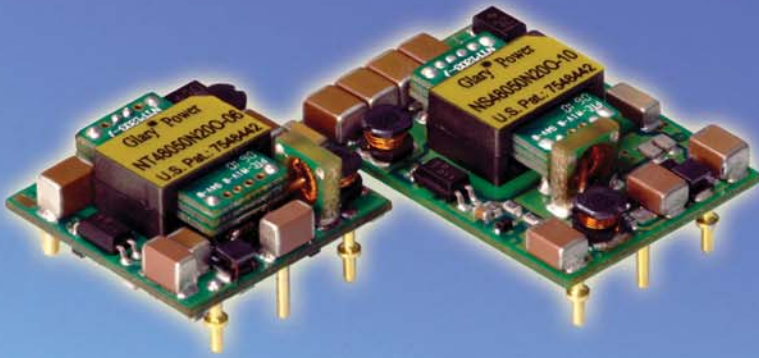

NS and N32 Series

1/16 Brick 50W /12A:

Inputs: 24V and 48V

Outputs: 2.5V, 3.3V, 5V and 12V

N32 Series 40W /10A:

0.91" X 0.91" Micro Brick

Inputs: 24V and 48V

Outputs: 2.5V, 3.3V, 5V and 12V

Metal Enclosed 50W



AB Series 2" X 1"

50W /12A:

Input: 24V and 48V

Outputs: 2.5V, 3.3V, 5V and 12V

Metal Enclosed 125W~2kW

1/8 Brick 130W/50A
Enclosed COE



Inputs: 24V and 48V
Outputs: 1.5V, 1.8V, 2.5V,
3.3V, 5V, 7V and 12V

1/4 Brick 125W/25A
CBQ Series



Inputs: 24V and 48V
Outputs: 1.5V, 1.8V, 2.5V,
3.3V and 5.0V

2X Brick 2kW/120A
PS Series



Input: 200V~420V
Outputs: 12V, 24V,
28V and 48V

1/4 Brick 300W/60A
Enclosed UQ



Inputs: 24V and 48V
Outputs: 3.3V, 5V, 7V and 12V

1/2 Brick 500W/42A
UH2H Series



Input: 200V~420V
Outputs: 12V, 28V and 48V

Efficiency >95% 370W/in³ Open Frame Package OCP 2.96Mhrs MTBF

Remote ON/OFF INPUT 2:1 OVP OTP

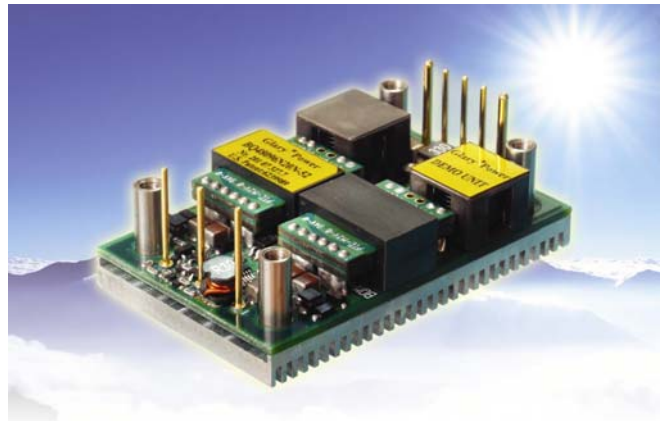

The **BQ** series provides up to 680W/60A outputs with industry standard quarter brick package. The efficient SR stage is combined with patented "Buck Reset" topology that would reduce power loss to achieve 370W/in³ power density. The multi-layer double-side circuit board design plus the patented Sink-Plate technology would enhance the thermal performance and improve its reliability. Modules are designed for Telecom, Servers, Networking equipments and other applications that use a 48V input bus.

Preliminary Data Sheet

PART NUMBER SYSTEM

BQ	X	096	a	b	c	d	-	60	XX	X
Series Name	Input Voltage Range	Output Voltage	Enable Logic	Pin Dimension	Standoff Height	Base-Plate		Output Current	Suffix	Version
UQ	X= 36V~60V Non-regulated N= 40V~60V Regulated W= 36V~72V Regulated	Unit: 0.1V Increments 096= 9.6V 065= 6.5V	P: Positive N: Negative	0 : 0.12" 1 : 0.16" 2 : 0.20" 3 : 0.24"	0 : 0.02" 1 : 0.08" 2 : 0.16"	M : 1.0mm Metal Plate A : 3.0mm Sink-Plate		00~60 : For output current rating		For marketing purpose only

MODEL LIST (Contact to factory for special input / output)

Part Number *	Maximum Input	Maximum Output	Efficiency	Part Number *	Maximum Input	Maximum Output	Efficiency
BQX096abcd-60XXX	36V~60V	730W	7.2-12V/60A 680W 96%				
BQN072abcd-40XXX	40V~60V	460W	7.2V/60A 432W 95%				
BQW065abcd-60XXX	36V~72V	430W	6.5V/60A 390W 94%				

REFERENCED THERMAL IMAGES

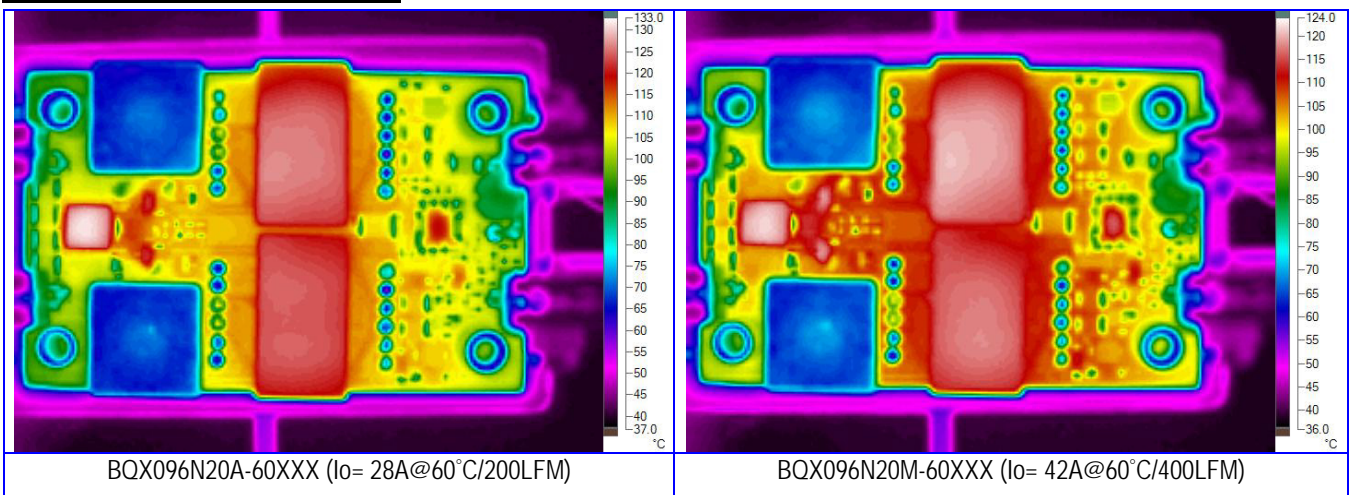

SPECIFICATIONS

Absolute Maximum Ratings		
Temperature	Operation Storage	-40°C to +110°C -55°C to +125°C
Input Voltage Range	Operation: 48V Models Transient (100mS): 48V Models	-0.5V to +80Vdc 100V Maximum
Isolation Voltage	Input to Output Input to Case Output to Case	1.5KV Minimum 1.0KV Minimum 1.0KV Minimum
Remote Control		-0.5V to +12Vdc

General Parameters		
Conversion Efficiency	Typical	See table
Switching Frequency	Typical	330KHz
MTBF	Bellcore TR-332 issue 6	2.96×10 ⁶ hrs @GB/25°C (BQ48096abcd-60XXX)
OTP	Internal	110°C(Tc) ±5°C
Weight	1.0mm metal plate 3.0mm metal plate	60g 75g

Control Functions		
Remote Control	Logic High Logic Low	+3.0V to +6.5V 0V to +1.0V
Input Current of Remote Control Pin		-0.5mA ~ +1.5mA

Input		
Operation Voltage Range	48V Models	See Part Number System
Reflected Ripple Current	L _{EXT} = 10uH	30mA rms/100mAp-p
Power ON Voltage Ranges	48V Models	+34.0V to +36.0Vdc
Power OFF Voltage Ranges	48V Models	+31.2V to +33.2Vdc
Off State Input Current	V _{NOM}	6mA Max
Latch-State Input Current	V _{NOM}	8mA Max
Input Capacitance	48V Models	12.0uF Max

Output		
Voltage Accuracy	Typical	Regulated: ±1.0% Non-regulated: ±5%
Line Regulation	Full Input Range	Regulated: ±0.3% Non-regulated: ±25%
Load Regulation	0%~100%	Regulated: ±0.3% Non-regulated: ±6%
Temperature Drift	-40°C ~100°C	Regulated: ±0.03%/°C Non-regulated: NA
Output Tolerance Band	All Conditions	Regulated: ±4% Non-regulated: NA
Ripple & Noise (20MHz)	Peak-Peak (RMS)	7% (2%) V _O
Over Voltage Protection	V _{NOM} , 10% Load	115~130 %V _{O(max)}
Output Current Limits	V _{NOM}	108%~125%
Voltage Trim	V _{NOM} , 10% Load	Regulated: ±10% Non-regulated: NA
Input Ripple Rejection (<1KHz)	V _{NOM} , Full Load	-50dB
Step Load (2.5A/μS)	50%~75% Load	Regulated: ±10%Vo/500μS Non-regulated: NA
Start-Up Delay Time	V _{NOM} , Full Load	20mS/250mS

PERFORMANCE CURVES

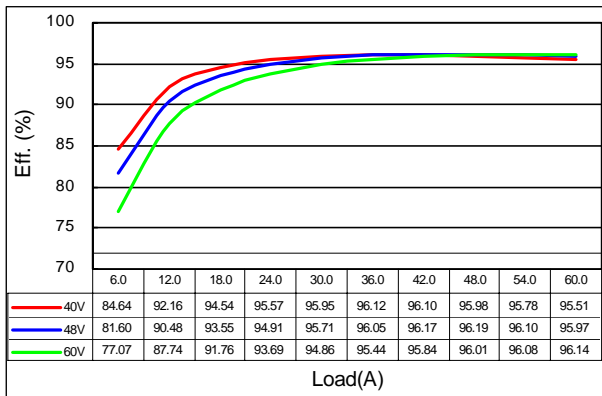

Efficiency plot of BQX096abcA-60XXX

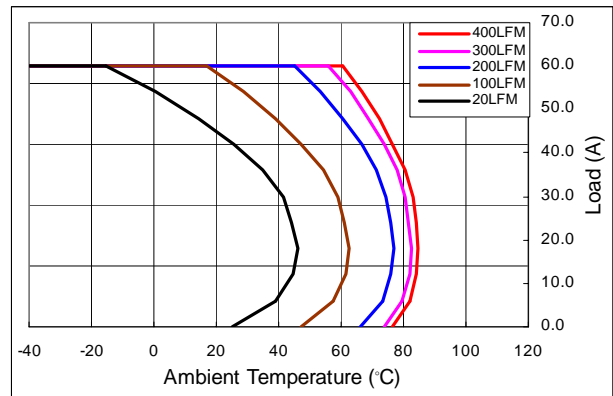

Derating curves of BQX096abcA-60XXX for $T_C = 110^\circ\text{C}$

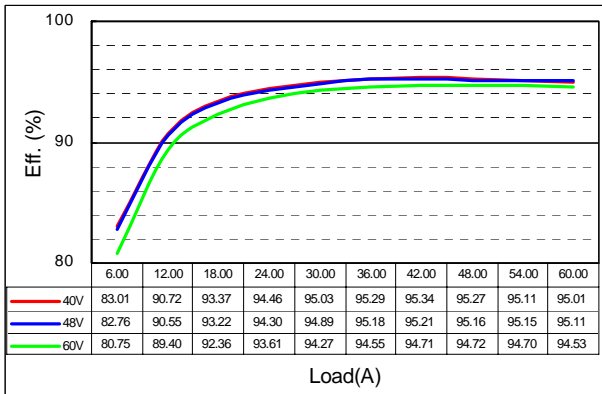

Efficiency plot of BQN8072abcA-60XXX

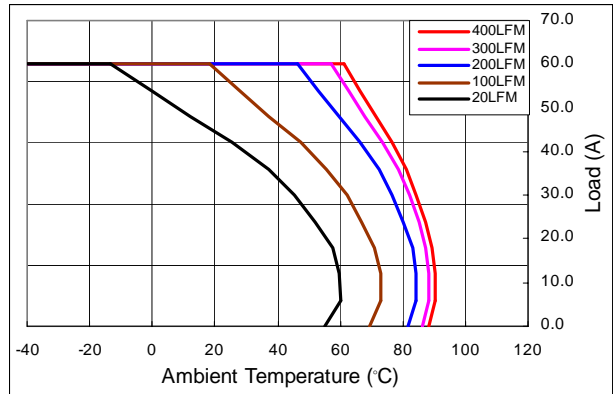

Derating curves of BQN8072abcA-60XXX for $T_C = 110^\circ\text{C}$

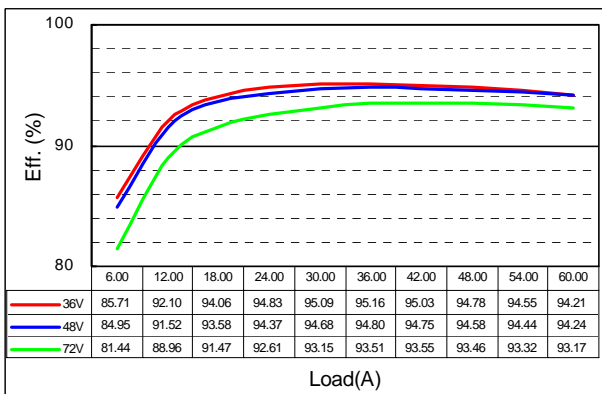

Efficiency plot of BQW8065abcA-60XXX

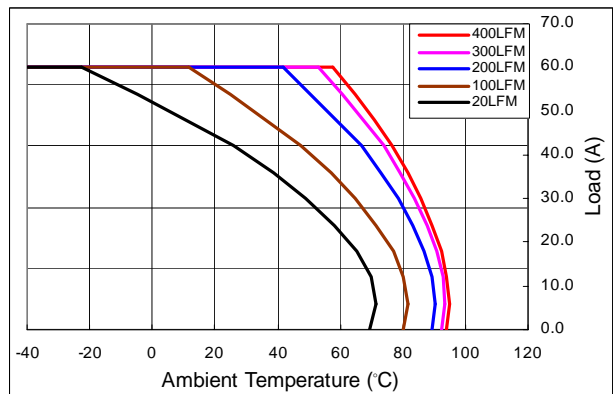

Derating curves of BQW8065abcA-60XXX for $T_C = 110^\circ\text{C}$

OPEN FRAME PACKAGE

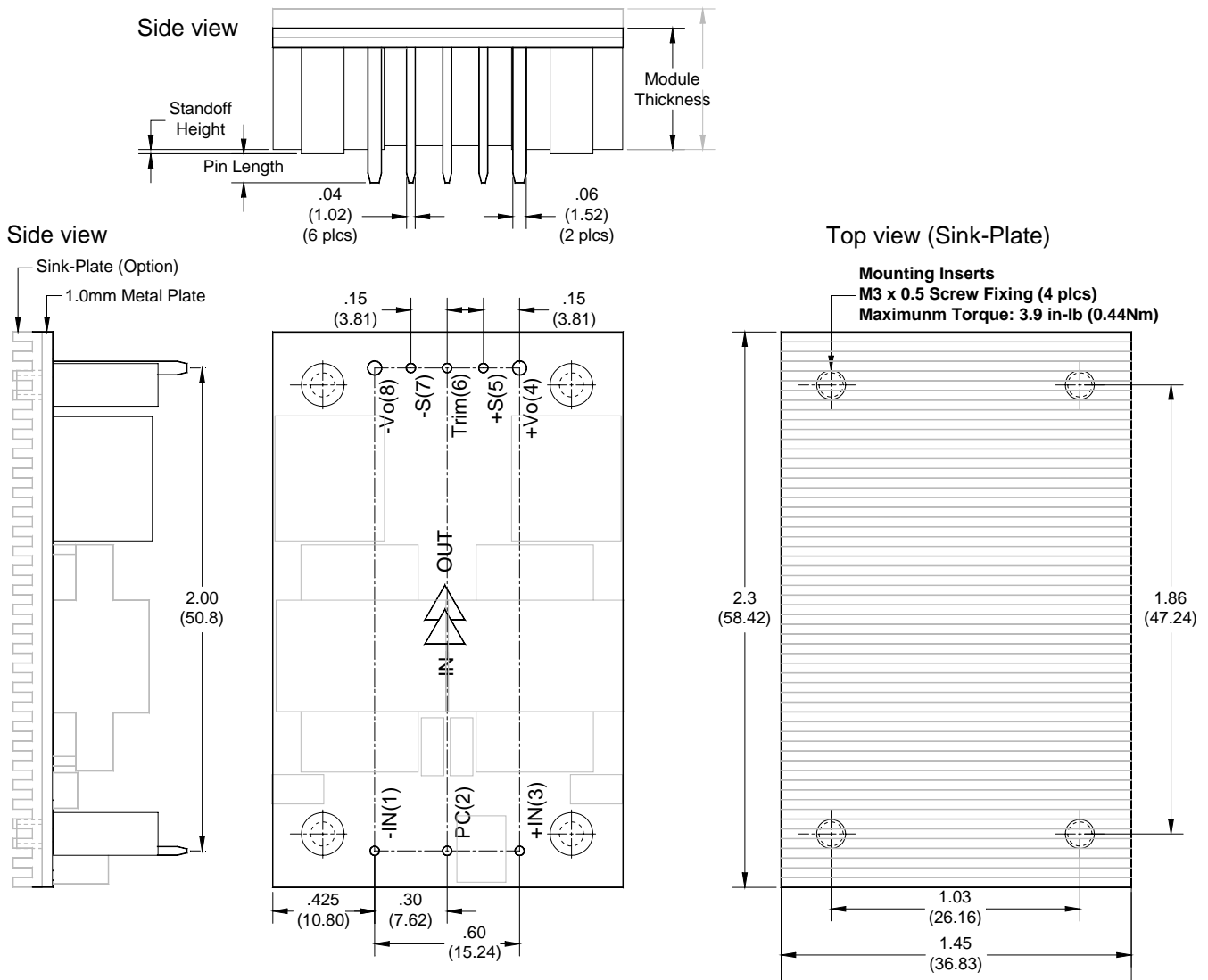

Dimensions and Pin Connections

Designation	Function Description	Pin #
-IN	Negative input	1
PC	Remote control. To turn-on and turn-off output.	2
+IN	Positive input	3
+Vo	Positive output	4
+S	Positive remote sense	5
TRIM	Output voltage adjust	6
-S	Negative remote sense	7
-Vo	Negative output	8

Dimensions: inches (mm)

Tolerances: .xx±0.02 (.x±0.5)
.xxx±0.01 (.x±0.25)

Weight: 60g / 1.0mm metal plate
75g / 3.0mm metal plate

Base plate: Aluminum alloy with anode oxide

Mounting inserts: Stainless steel
Maximum torque: 3.9 in-lb (0.44Nm)

Pin material: Copper alloy or Brass

Pin plating: Golden over Nickel

Efficiency >93% 226W/in³ Open Frame Package OCP 6.4Mhrs MTBF

Remote ON/OFF INPUT 2:1 OVP OTP

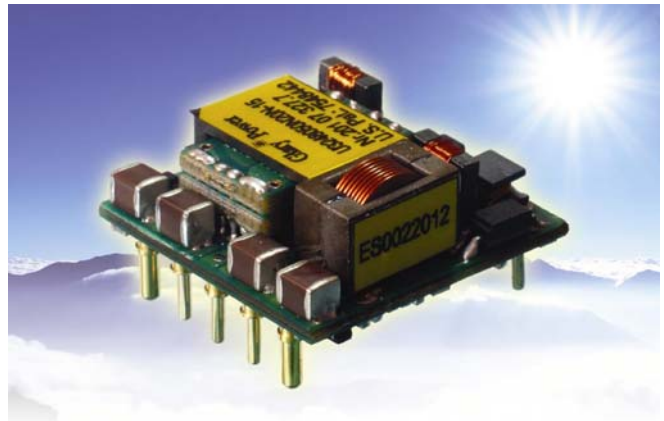

The high efficiency **U32** series provides up to 80W/20A output with 0.91"×0.91" Micro-Brick package, which is designed with the efficiently patented "Buck-Reset" topology. The low profile module design with open frame package reduces the shadow effect and provides the advanced thermal performance to simplify the system power design for users.

PART NUMBER SYSTEM

Preliminary Data Sheet

U32	48	050	a	b	c	d	-	15	XX	X
Series Name	Input Voltage	Output Voltage	Enable Logic	Pin Dimension	Standoff Height	Base-Plate		Output Current	Suffix	Version
U32	48=36V~75V	Unit: 0.1V Increments 120=12V 050=5V	P: Positive N: Negative	0 : 0.12" 1 : 0.16" 2 : 0.20"	0 : 0.02"	O : Open frame standard type		00~20 : For output current rating	For marketing purpose only	

MODEL LIST (Contact to factory for special input / output)

Part Number *	Maximum Input	Maximum Output	Efficiency	Part Number *	Maximum Input	Maximum Output	Efficiency
U3248120abcd-03XXX	36V~75V	91W	12.0V/7A 84W 94%				
U3248050abcd-08XXX	36V~75V	83W	5.0V/15A 75W 92%				
U3248033abcd-10XXX	36V~75V	57W	3.3V/15A 50W 90%				
U3248025abcd-10XXX	36V~75V	57W	2.5V/20A 50W 90%				

REFERENCED THERMAL IMAGES

To be updated in next version	To be updated in next version
-------------------------------	-------------------------------

SPECIFICATIONS

Absolute Maximum Ratings		
Temperature	Operation Storage	-40°C to +110°C -55°C to +125°C
Input Voltage Range	Operation: 48V Models Transient (100mS): 48V Models	-0.5V to +80Vdc 100V Maximum
Isolation Voltage	Input to Output	2.0KV Minimum
Remote Control		-0.5V to +12Vdc

General Parameters		
Conversion Efficiency	Typical	See table
Switching Frequency	Typical	400KHz
MTBF	Bellcore TR-332 issue 6	6.4×10 ⁶ hrs @GB/25°C (NT48050abcd-10XXX)
OTP	Internal	110°C(Tc) ±5°C
Weight	1/32 Brick	12g

Control Functions		
Remote Control	Logic High Logic Low	+3.0V to +6.5V 0V to +1.0V
Input Current of Remote Control Pin		-0.5mA ~ +1.5mA

Input		
Operation Voltage Range	48V Models	+36V to +75Vdc
Reflected Ripple Current	L _{EXT} = 10uH	30mA rms/100mAp-p
Power ON Voltage Ranges	48V Models	+34.0V to +36.0Vdc
Power OFF Voltage Ranges	48V Models	+31.2V to +33.2Vdc
Off State Input Current	V _{NOM}	3mA Max
Latch-State Input Current	V _{NOM}	8mA Max
Input Capacitance	48V Models	6.0uF Max

Output		
Voltage Accuracy	Typical	±1.0%
Line Regulation	Full Input Range	±0.2%
Load Regulation	10%~100%	±0.2%
Temperature Drift	-40°C ~100°C	±0.03%/°C
Output Tolerance Band	All Conditions	±4%
Ripple & Noise (20MHz)	Peak-Peak (RMS)	3% (1%) V _O
Over Voltage Protection	V _{NOM} , 10% Load	115~130 %V _O
Output Current Limits	V _{NOM}	108%~125%
Voltage Trim	V _{NOM} , 10% Load	±10%
Input Ripple Rejection (<1KHz)	V _{NOM} , Full Load	-50dB
Step Load (2.5A/μS)	50%~75% Load	±6%Vo/500μS
Start-Up Delay Time	V _{NOM} , Full Load	20mS/250mS

TYPICAL WAVES AND CURVES

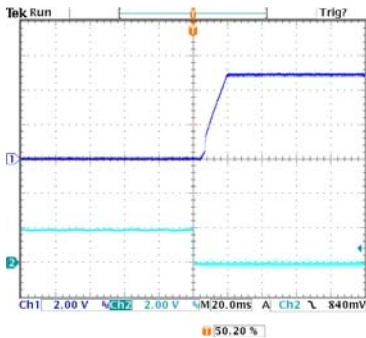

Start-up waveform of U3248050abcd-15XXX
(V_{IN} : 48V, Load: 15A)

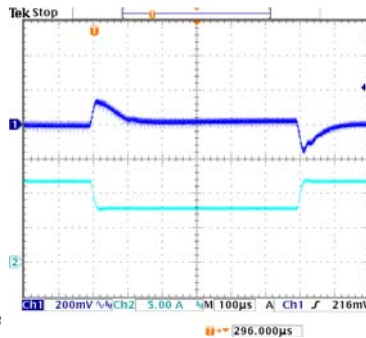

Transient response of U3248050abcd-15XXX
(V_{IN} : 48V, Load: 12A/8.0A@2.5A/µs)

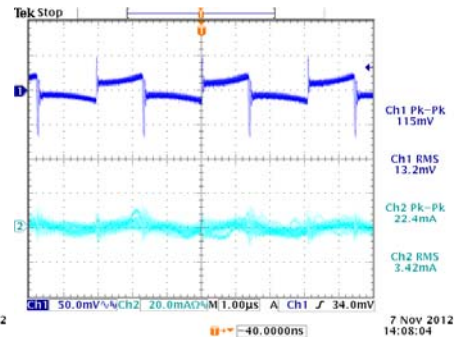

Input/Output ripples of U3248050abcd-15XXX
(V_{IN} : 48V, Load: 15A, L_{IN} =10µH)

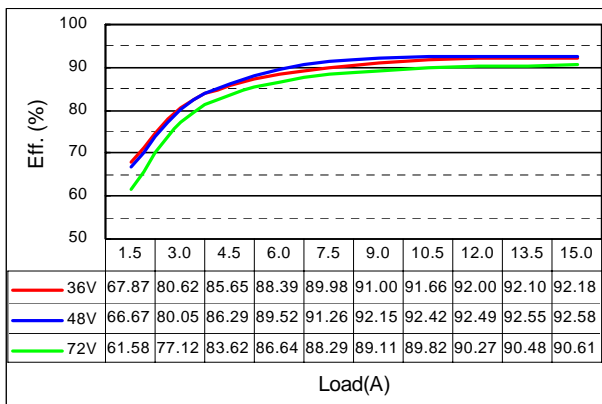

Efficiency plot of U3248050abcd-15XXX

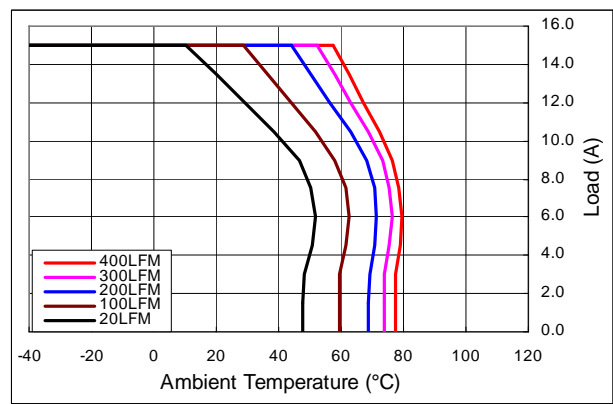

Derating curves of U3248050abcd-15XXX for $T_C = 110^\circ\text{C}$

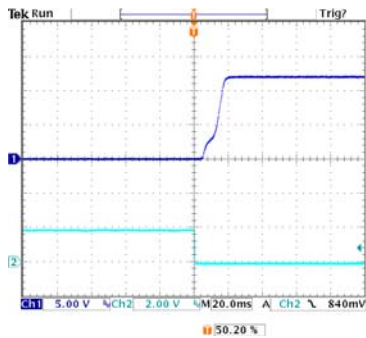

Start-up waveform of U3248120abcd-07XXX
(V_{IN} : 48V, Load: 7A)

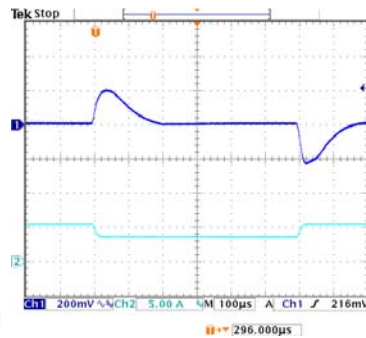

Transient response of U3248120abcd-07XXX
(V_{IN} : 48V, Load: 5A/3A@2.5A/µs)

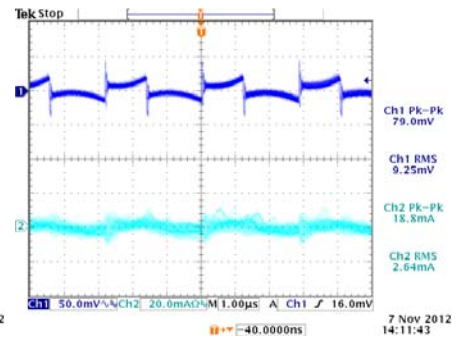

Input/Output ripples of U3248120abcd-07XXX
(V_{IN} : 48V, Load: 7A, L_{IN} =10µH)

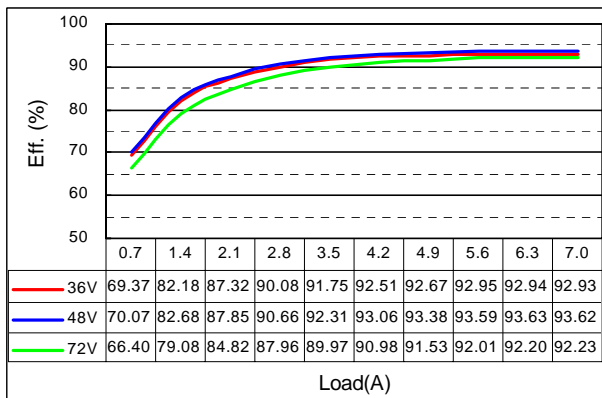

Efficiency plot of U3248120abcd-07XXX

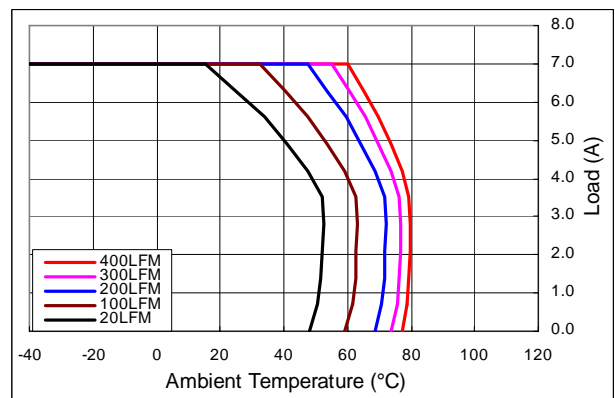

Derating curves of U3248120abcd-07XXX for $T_C = 110^\circ\text{C}$

OPEN FRAME PACKAGE

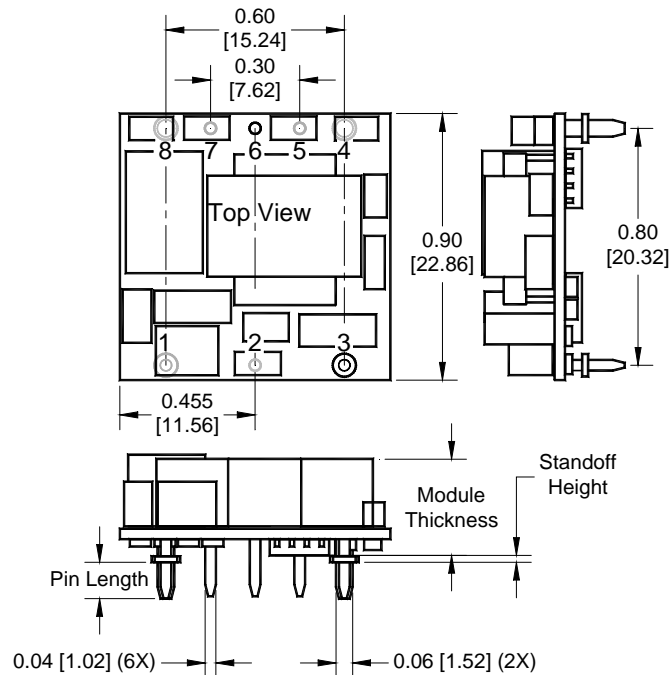

Micro Brick U32 series

Dimensions and Pin Connections

Designation	Function Description	Pin #
+Vi	Positive input	1
Remote	ON/OFF control	2
-Vi	Negative input	3
-Vo	Negative output	4
-S	Negative remote sense	5
TRIM	Output voltage adjust	6
+S	Positive remote sense	7
+Vo	Positive output	8

Dimensions: inches (mm)

Tolerances: .xx±0.02 (.x±0.5)
.xxx±0.01 (.x±0.25)

Mass: 8g / Micro brick N32 series
10g / NS series 1/16 brick

Base plate: None

Pin material: Copper alloy or Brass

Pin plating: Golden over Nickel

NOTE:

1. It is recommended that the input should be protected by fuses or other protection devices.
2. All specifications are typical at nominal input, full load and 25°C unless otherwise noted.
3. Specifications are subject to change without notice.
4. Printed or downloaded datasheets are not subject to Glary document control.
5. Product labels shown, including safety agency certificates, may vary based on the date of manufacture.
6. Information provided in this documentation is for ordering purposes only.
7. This product is not designed for use in critical life support systems, equipment used in hazardous environments, nuclear control systems or other such applications, which necessitate specific safety and regulatory standards other than the ones listed in this datasheet.

IMPORTANT

- ✳ General specifications and the performances are related to standard series only, no special customer specification display here except requested items.
- ✳ In order to secure effective usage of converter and the validity of Glary's service and warranty coverage, please refer to the application notes for general usage. For needs of usage beyond the application notes, please contact to Glary headquarter or our regional sales representative office for help.

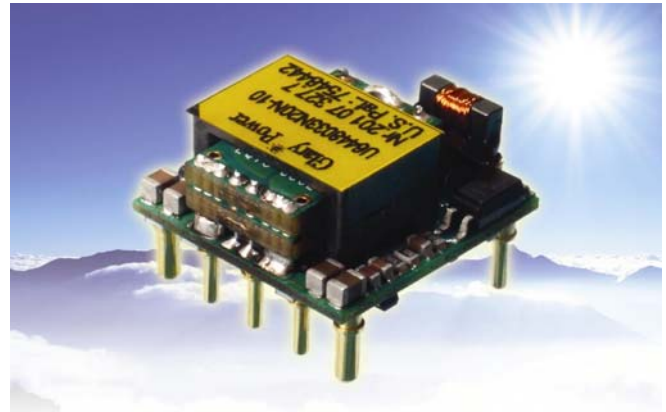

The ultra-compact high efficiency **U64** Nano-brick provides up to 40W/8A output with 0.7"×0.7" footprint, which is designed with the efficiently patented "Coupled-Inductor SR" topology. The DOSA compatible pin assignments and 60% more of available power are designed to help system designers with up to 50% of space saving for the power circuit area in the majority of the current application boards by simply a drop in replacement for system upgrade.

Preliminary Data Sheet

PART NUMBER SYSTEM

U64	48	050	a	b	c	d	-	08	XX	X
Series Name	Input Voltage	Output Voltage	Enable Logic	Pin Dimension	Standoff Height	Base-Plate		Output Current	Suffix	Version
U64	48=36V~75V	Unit: 0.1V Increments 120=12V 050=5V	P: Positive N: Negative	0 : 0.12" 1 : 0.16" 2 : 0.20"	0 : 0.02"	O : Open frame standard type	-	00-08 : For output current rating	For marketing purpose only	

MODEL LIST (Contact to factory for special input / output)

Part Number *	Maximum Input	Maximum Output	Efficiency	Part Number *	Maximum Input	Maximum Output	Efficiency
U6448120abcd-03XXX	36V~75V	44W	12.0V/3.3A 40W 93%				
U6448050abcd-08XXX	36V~75V	45W	5.0V/8A 40W 91%				
U6448033abcd-10XXX	36V~75V	37W	3.3V/8A 27W 89%				
N6448025abcd-10XXX	36V~75V	29W	2.5V/8A 25W 87%				

REFERENCED THERMAL IMAGES

To be updated in next version	To be updated in next version
U6448033abcO-08 (I _o = ?A@50°C/100LFM)	U6448033abcO-08 (I _o = ?A@55°C/200LFM)

SPECIFICATIONS

Absolute Maximum Ratings		
Temperature	Operation Storage	-40°C to +110°C -55°C to +125°C
Input Voltage Range	Operation: 48V Models Transient (100mS): 48V Models	-0.5V to +80Vdc 100V Maximum
Isolation Voltage	Input to Output	2.0KV Minimum
Remote Control		-0.5V to +12Vdc

General Parameters		
Conversion Efficiency	Typical	See table
Switching Frequency	Typical	400KHz
MTBF	Bellcore TR-332 issue 6	7.6×10 ⁶ hrs @GB/25°C (U6448050abcd-08XXX)
OTP	Internal	110°C(Tc) ±5°C
Weight		6g

Control Functions		
Remote Control	Logic High Logic Low	+3.0V to +6.5V 0V to +1.0V
Input Current of Remote Control Pin		-0.5mA ~ +1.5mA

Input		
Operation Voltage Range	48V Models	+36V to +75Vdc
Reflected Ripple Current	L _{EXT} = 10uH, C _{EXT} = 47uF	30mA rms/100mAp-p
Power ON Voltage Ranges	48V Models	+34.0V to +36.0Vdc
Power OFF Voltage Ranges	48V Models	+31.2V to +33.2Vdc
Off State Input Current	V _{NOM}	3mA Max
Latch-State Input Current	V _{NOM}	8mA Max
Input Capacitance	48V Models	6.0uF Max

Output		
Voltage Accuracy	Typical	±1.0%
Line Regulation	Full Input Range	±0.2%
Load Regulation	10%~100%	±0.2%
Temperature Drift	-40°C ~100°C	±0.03%/°C
Output Tolerance Band	All Conditions	±4%
Ripple & Noise (20MHz)	Peak-Peak (RMS)	3% (1%) V _O
Over Voltage Protection	V _{NOM} , 10% Load	115~130 %V _O
Output Current Limits	V _{NOM}	108%~125%
Voltage Trim	V _{NOM} , 10% Load	±10%
Input Ripple Rejection (<1KHz)	V _{NOM} , Full Load	-50dB
Step Load (2.5A/μS)	50%~75% Load	±6%Vo/500μS
Start-Up Delay Time	V _{NOM} , Full Load	20mS/250mS

TYPICAL WAVES AND CURVES

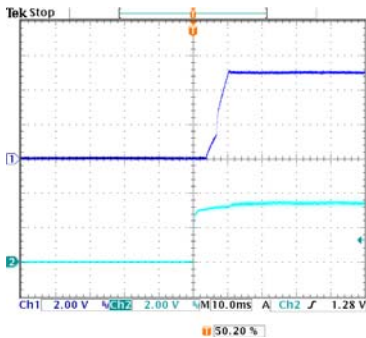

Start-up waveform of U6448050abcd-08XXX
(V_{IN} : 48V, Load: 8A)

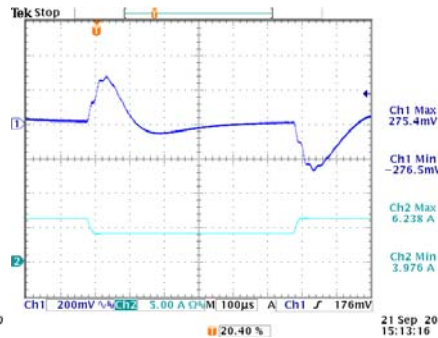

Transient response of U6448050abcd-08XXX
(V_{IN} : 48V, Load: 6.0A/4.0A@2.5A/ μ S)

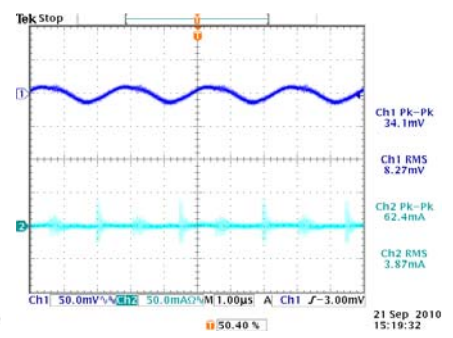

Input/Output ripples of U6448050abcd-08XXX
(V_{IN} : 48V, Load: 8A, L_{IN} =10uH, C_{IN} =47uF)

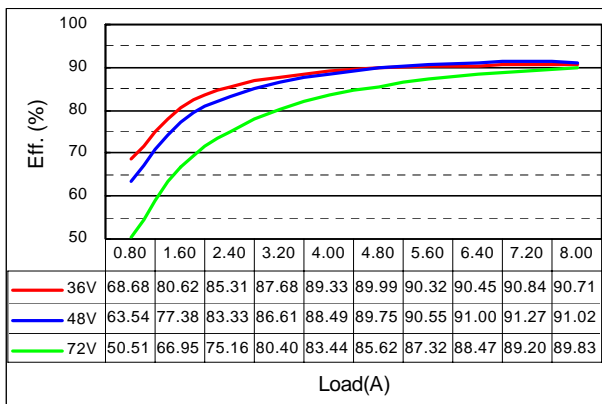

Efficiency plot of U6448050abcd-08XXX

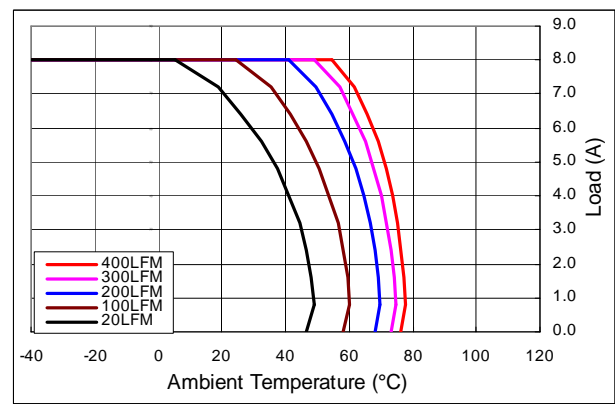

Derating curves of U6448050abcd-08XXX for $T_c = 110^\circ\text{C}$

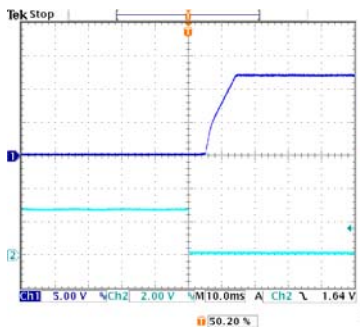

Start-up waveform of U6448120N000-03XXX
(V_{IN} : 48V, Load: 3.3A)

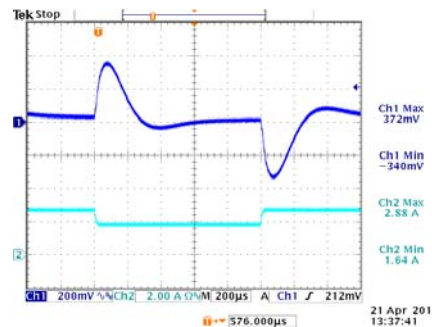

Transient response of U6448120N000-04XXX
(V_{IN} : 48V, Load: 2.5A/1.65A@2.5A/ μ S)

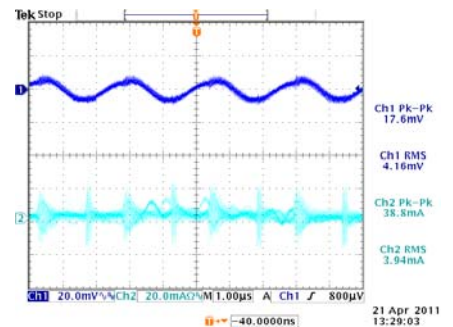

Input/Output ripples of U6448120N000-04XXX
(V_{IN} : 48V, Load: 3.3A, L_{IN} =10uH)

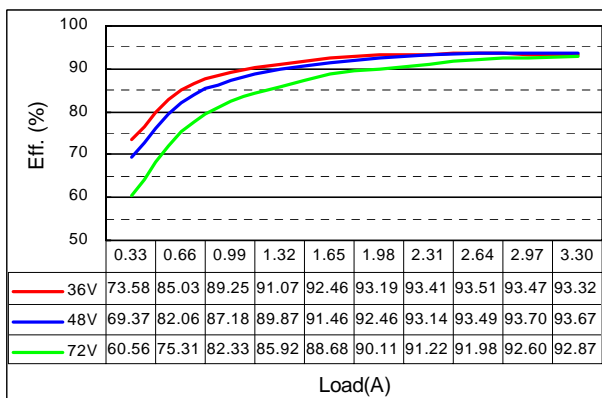

Efficiency plot of U6448120N000-03XXX

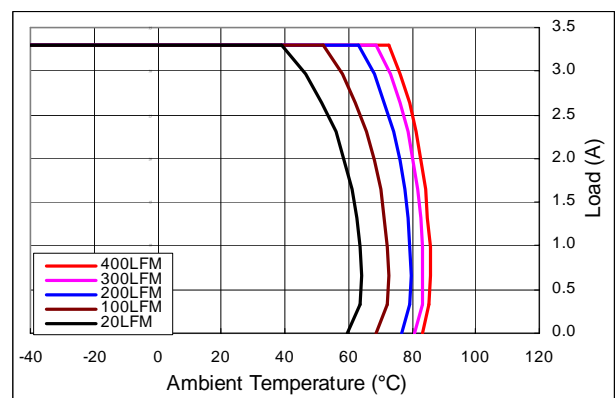

Derating curves of U6448120N000-03XXX for $T_c = 110^\circ\text{C}$

OPEN FRAME PACKAGE

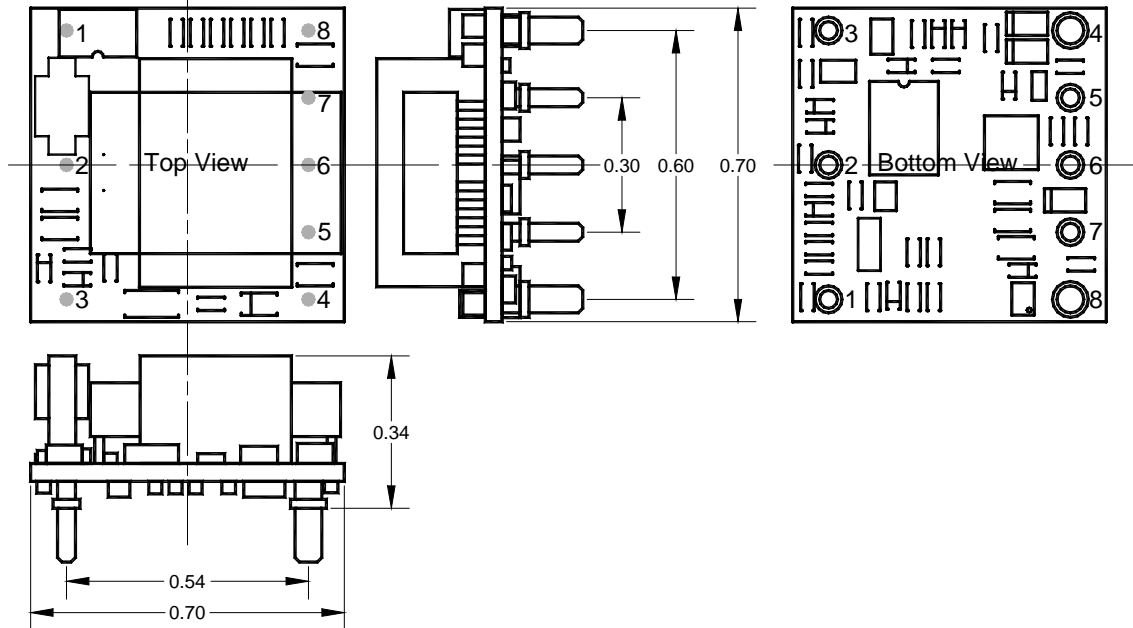

Nano-Brick U64 series

Dimensions and Pin Connections

Designation	Function Description	Pin #
+Vi	Positive input	1
Remote	ON/OFF control	2
-Vi	Negative input	3
-Vo	Negative output	4
-S	Negative remote sense	5
TRIM	Output voltage adjust	6
+S	Positive remote sense	7
+Vo	Positive output	8

Dimensions: inches (mm)

Tolerances: .xx±0.02 (.x±0.5)
.xxx±0.01 (.x±0.25)

Mass: 6g / Nano brick

Base plate: None

Pin material: Copper alloy or Brass

Pin plating: Golden over Nickel

NOTE:

1. It is recommended that the input should be protected by fuses or other protection devices.
2. All specifications are typical at nominal input, full load and 25°C unless otherwise noted.
3. Specifications are subject to change without notice.
4. Printed or downloaded datasheets are not subject to Glary document control.
5. Product labels shown, including safety agency certificates, may vary based on the date of manufacture.
6. Information provided in this documentation is for ordering purposes only.
7. This product is not designed for use in critical life support systems, equipment used in hazardous environments, nuclear control systems or other such applications, which necessitate specific safety and regulatory standards other than the ones listed in this datasheet.

IMPORTANT

- ✳ General specifications and the performances are related to standard series only, no special customer specification display here except requested items.
- ✳ In order to secure effective usage of converter and the validity of Glary's service and warranty coverage, please refer to the application notes for general usage. For needs of usage beyond the application notes, please contact to Glary headquarter or our regional sales representative office for help.

Efficiency >90%	50W/in³	Full Metal Package	EN55022 Class B	7.6Mhrs MTBF
Remote ON OFF	INPUT 2:1	OVP	OTP	OCP

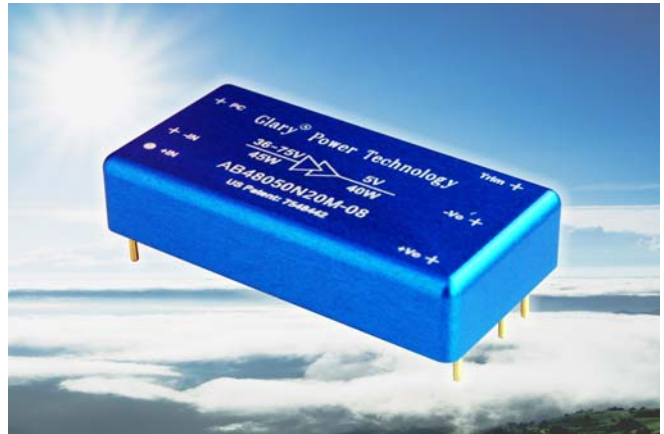

The high efficiency **Aurora** Converter provides up to 50W/10A output with industry standard “B” case (2” x 1”) package. The power stage is designed with the efficiently patented “Coupled-Inductor SR” topology, which results in very high efficiency. The low profile module design with silicone potted metal package eliminates the hot spots and further secures better thermal performance.

PART NUMBER SYSTEM

AB	48	050	a	b	c	d	-	10	XX	X
Series Name	Input Voltage	Output Voltage	Enable Logic	Pin Dimension	Standoff Height	Base-Plate		Output Current	Suffix	Version
AB	48=36V~75V 24=18V~36V	Unit: 0.1V Increments 120=12V 050=5V	P: Positive N: Negative	0 : 0.12" 1 : 0.16"	0 : 0.00"	E : Enclosed standard type	-	00~12 : For output current rating	For marketing purpose only	

MODEL LIST (Contact to factory for special input / output)

Part Number *	Maximum Input		Maximum Output		Efficiency	Part Number *	Maximum Input		Maximum Output		Efficiency
AB48120abcd-04XXX	36V~75V	55W	12.0V/4.2A	50W	91%	AB24120abcd-04XXX	18V~36V	55W	12.0V/4.2A	50W	91%
AB48050abcd-10XXX	36V~75V	56W	5.0V/10A	50W	90%	AB24050abcd-10XXX	18V~36V	56W	5.0V/10A	50W	90%
AB48033abcd-12XXX	36V~75V	45W	3.3V/12A	40W	88%	AB24033abcd-12XXX	18V~36V	45W	3.3V/12A	40W	88%
AB48025abcd-12XXX	36V~75V	35W	2.5V/12A	30W	86%	AB24025abcd-12XXX	18V~36V	35W	2.5V/12A	30W	86%

REFERENCED THERMAL IMAGES

To be updated in next version	To be updated in next version
-------------------------------	-------------------------------

SPECIFICATIONS

Absolute Maximum Ratings		
Temperature	Operation Storage	-40°C to +110°C -55°C to +125°C
Input Voltage Range	Operation: 24V Models 48V Models Transient (100mS): 24V Models 48V Models	-0.5V to +40Vdc -0.5V to +80Vdc 50V Maximum 100V Maximum
Isolation Voltage	Input to Output Input to Case Output to Case	2.0KV Minimum 1.0KV Minimum 0.5KV Minimum
Remote Control		-0.5V to +12Vdc

General Parameters		
Conversion Efficiency	Typical	See table
Switching Frequency	Typical	400KHz
MTBF	Bellcore TR-332 issue 6	7.6×10 ⁶ hrs @GB/25°C (AB48050abcd-08)
OTP	Internal	110°C(Tc) ±5°C
Weight		35g

Control Functions		
Remote Control	Logic High Logic Low	+3.0V to +6.5V 0V to +1.0V
Input Current of Remote Control Pin		-0.5mA ~ +1.5mA

Input		
Operation Voltage Range	24V Models 48V Models	+18V to +36Vdc +36V to +75Vdc
Reflected Ripple Current	L _{EXT} = 10uH	20mA Max
Power ON Voltage Ranges	24V Models 48V Models	+17.0V to +18.0Vdc +34.0V to +36.0Vdc
Power OFF Voltage Ranges	24V Models 48V Models	+15.6V to +16.6Vdc +31.2V to +33.2Vdc
Off State Input Current	V _{NOM}	3mA Max
Latch-State Input Current	V _{NOM}	8mA Max
Input Capacitance	24V Models 48V Models	10.0uF Max 6uF Max

Output		
Voltage Accuracy	Typical	±1.0%
Line Regulation	Full Input Range	±0.2%
Load Regulation	0%~100%	±0.2%
Temperature Drift	-40°C ~100°C	±0.03%/°C
Output Tolerance Band	All Conditions	±4%
Ripple & Noise (20MHz)	Peak-Peak (RMS)	3% (1%) V _O
Over Voltage Protection	V _{NOM} , 10% Load	115~130 %V _O
Output Current Limits	V _{NOM}	108%~125%
Voltage Trim	V _{NOM} , 10% Load	±10%
Input Ripple Rejection (<1KHz)	V _{NOM} , Full Load	-50dB
Step Load (2.5A/μS)	50%~75% Load	±8%Vo /500μS
Start-Up Delay Time	V _{NOM} , Full Load	20mS/250mS

TYPICAL WAVES AND CURVES

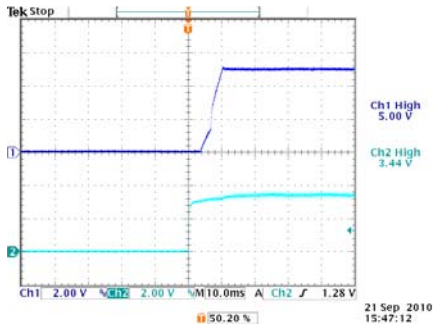

Start-up waveform of AB24050abcd-10XXX
(V_{IN} : 24V, Load: 10A)

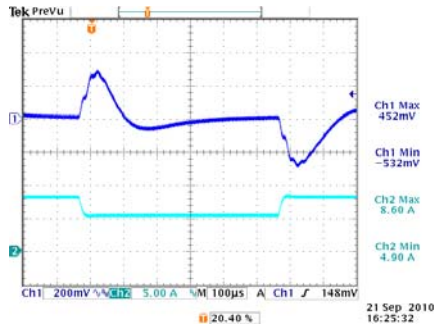

Transient response of AB24050abcd-10XXX
(V_{IN} : 24V, Load: 8.5A/5A@2.5A/ μ S)

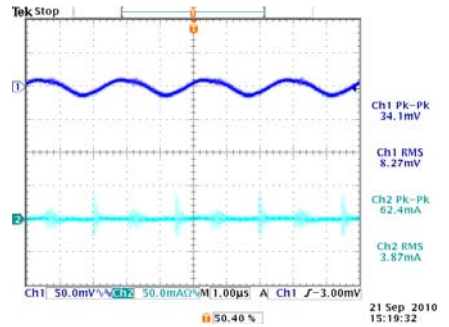

Input/Output ripples of AB24050abcd-10XXX
(V_{IN} : 24V, Load: 10A, L_{IN} =10uH)

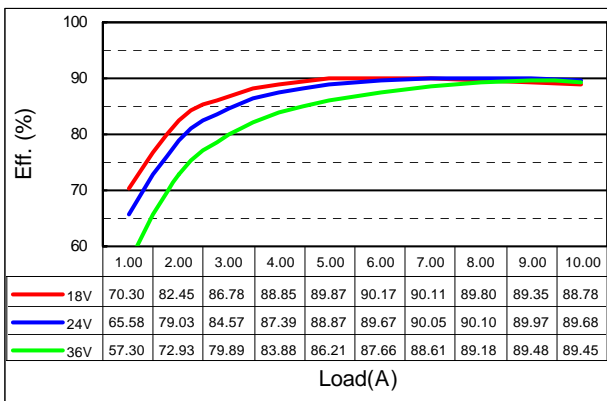

Efficiency Plot of AB24050abcd-10XXX

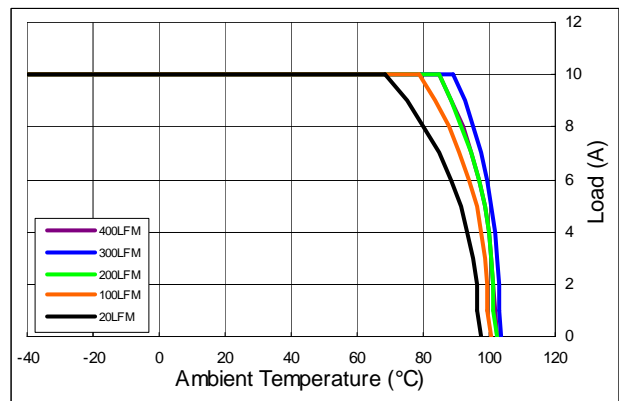

Derating Curves of AB24050abcd-10XXX for T_C = 110°C

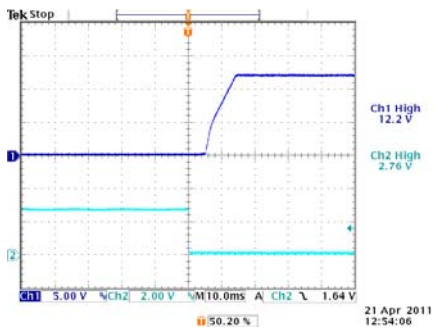

Start-up waveform of AB24120abcd-04XXX
(V_{IN} : 24V, Load: 4.2A)

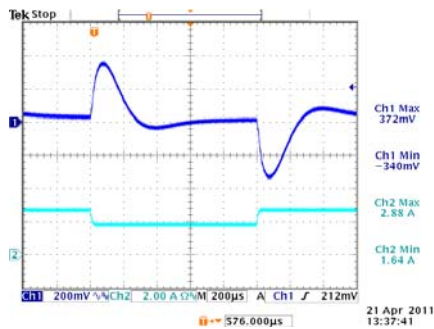

Transient response of AB24120abcd-04XXX
(V_{IN} : 24V, Load: 3A/2A@2.5A/ μ S)

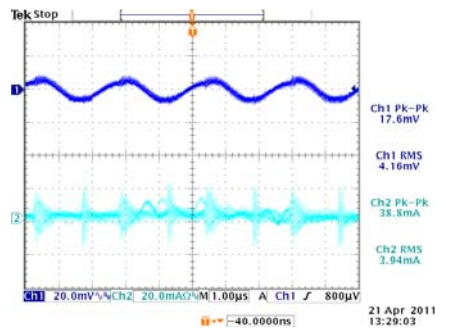

Input/Output ripples of AB24120abcd-04XXX
(V_{IN} : 24V, Load: 4.2A, L_{IN} =10uH)

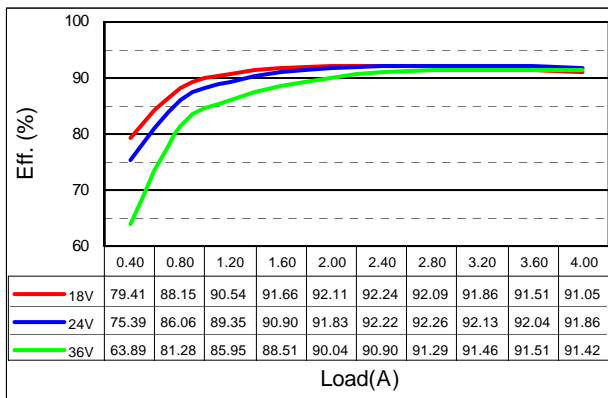

Efficiency plot of AB24120abcd-04XXX

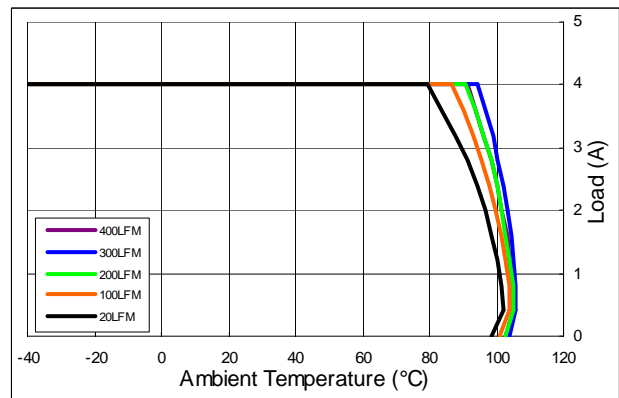

Derating curves of AB24120abcd-04XXX for T_C = 110°C

METAL ENCLOSED PACKAGE

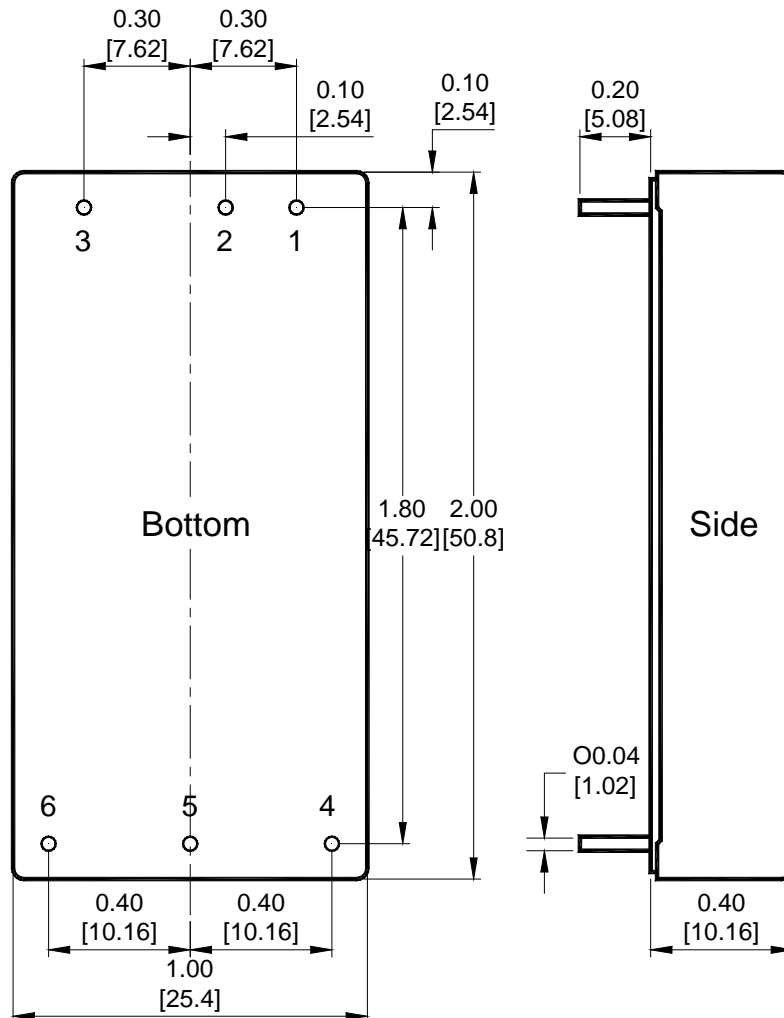

Dimensions and Pin Connections

Designation	Function Description	Pin #
+Vi	Positive input	1
-IN	Negative input	2
Remote	ON/OFF control	3
+Vo	Positive output	4
-Vo	Negative output	5
TRIM	Output voltage adjust	6

Dimensions: inches (mm)

Tolerances: .xx±0.02 (.x±0.5)
.xxx±0.01 (.x±0.25)

Weight: 35g

Base plate: Non-conductive

Pin material: Copper alloy or Brass

Pin plating: Golden over Nickel

REFERENCED EMC CIRCUIT

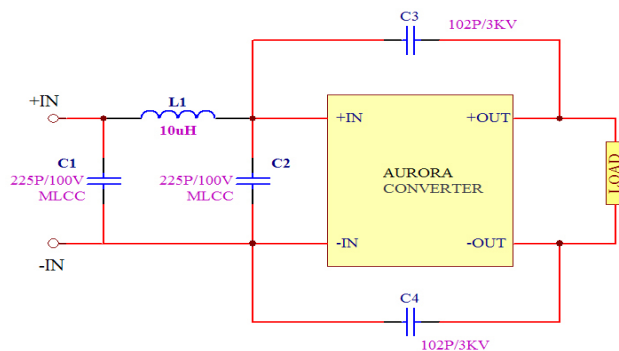
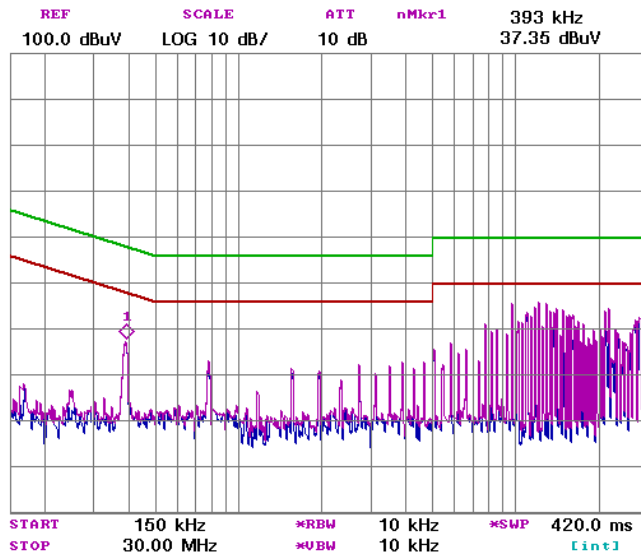

Measured conductive level of AB48050abcd-08XXX and referenced filter circuit

Referenced EMC Performance

The tested result shown in left-hand side is obtained by loading the power module with a resistive load only. It can be used as a design reference for customer system. However! The performance of customer's system depends on the whole system design. It should be noted that modifications on the circuit parameters and fine adjustment of the final layout affect the final EMC performance greatly.

Bandwidth of EMC Components

No components are ideal for infinite frequency range. The bandwidth of EMC components should be taking into consideration when designing an EMC filter circuit. To connect ceramic capacitor with electricity capacitor in parallel and connect low inductance inductor with big one could get a better bandwidth.

NOTE:

1. It is recommended that the input should be protected by fuses or other protection devices.
2. All specifications are typical at nominal input, full load and 25°C unless otherwise noted.
3. Specifications are subject to change without notice.
4. Printed or downloaded datasheets are not subject to Glary document control.
5. Product labels shown, including safety agency certificates, may vary based on the date of manufacture.
6. Information provided in this documentation is for ordering purposes only.
7. This product is not designed for use in critical life support systems, equipment used in hazardous environments, nuclear control systems or other such applications, which necessitate specific safety and regulatory standards other than the ones listed in this datasheet.

IMPORTANT

- ✳ General specifications and the performances are related to standard series only, no special customer specification display here except requested items.
- ✳ In order to secure effective usage of converter and the validity of Glary's service and warranty coverage, please refer to the application notes for general usage. For needs of usage beyond the application notes, please contact to Glary headquarter or our regional sales representative office for help.

Efficiency >91%	126W/in ³	Open Frame Package	Full Metal Package	3.3Mhrs MTBF
Remote ON/OFF	INPUT 2:1	OVP	OTP	OCP
UL US E219417		SAFETY DISPLAY TYPE APPROVED		CE
Pb		RoHS 2002/95/EC		



The **CBH** series provides up to 250W/60A outputs with industry standard half brick package. The efficient SR stage is combined with patented "Buck Reset" topology that would reduce power loss to achieve 126W/in³ power density. The single side component and multi-layer circuit board circuit board design plus the patented Sink-Plate technology would enhance the thermal performance and improve its reliability. Modules are designed for Telecom, Servers, Networking equipments and other applications that use a 24V or 48V input bus.

PART NUMBER SYSTEM

CBH	48	050	a	b	c	d	-	50	XX	X
Series Name	Input Voltage	Output Voltage	Enable Logic	Pin Dimension	Standoff Height	Base-Plate		Output Current	Suffix	Version
CBH	48=36V~75V 24=18V~36V	Unit: 0.1V Increments 050=5V 033=3.3V	P: Positive N: Negative	0 : 0.12" 1 : 0.16" 2 : 0.20" 3 : 0.24"	0 : 0.02" 1 : 0.08" 2 : 0.16"	M : 1.0mm Metal Plate A : 3.0mm Sink-Plate B : 5.0mm Sink-Plate E : Metallic enclosure (1.0mm metal plate)		00~60 : For output current rating		For marketing purpose only

MODEL LIST (Contact to factory for special input / output)

Part Number *	Maximum Input	Maximum Output	Efficiency	Part Number *	Maximum Input	Maximum Output	Efficiency
CBH48050abcd-50XXX	36V~75V 280W	5.0V/50A 250W	91%	CBH24050abcd-50XXX	18V~36V 280W	5.0V/50A 250W	90%
CBH48033abcd-50XXX	36V~75V 186W	3.3V/50A 165W	90%	CBH24033abcd-50XXX	18V~36V 186W	3.3V/50A 165W	89%
CBH48025abcd-60XXX	36V~75V 173W	2.5V/60A 150W	87%	CBH24025abcd-60XXX	18V~36V 173W	2.5V/60A 150W	87%
CBH48018abcd-60XXX	36V~75V 127W	1.8V/60A 108W	85%	CBH24018abcd-60XXX	18V~36V 127W	1.8V/60A 108W	85%
CBH48015abcd-60XXX	36V~75V 109W	1.5V/60A 90W	83%	CBH24015abcd-60XXX	18V~36V 109W	1.5V/60A 90W	83%

REFERENCED THERMAL IMAGES

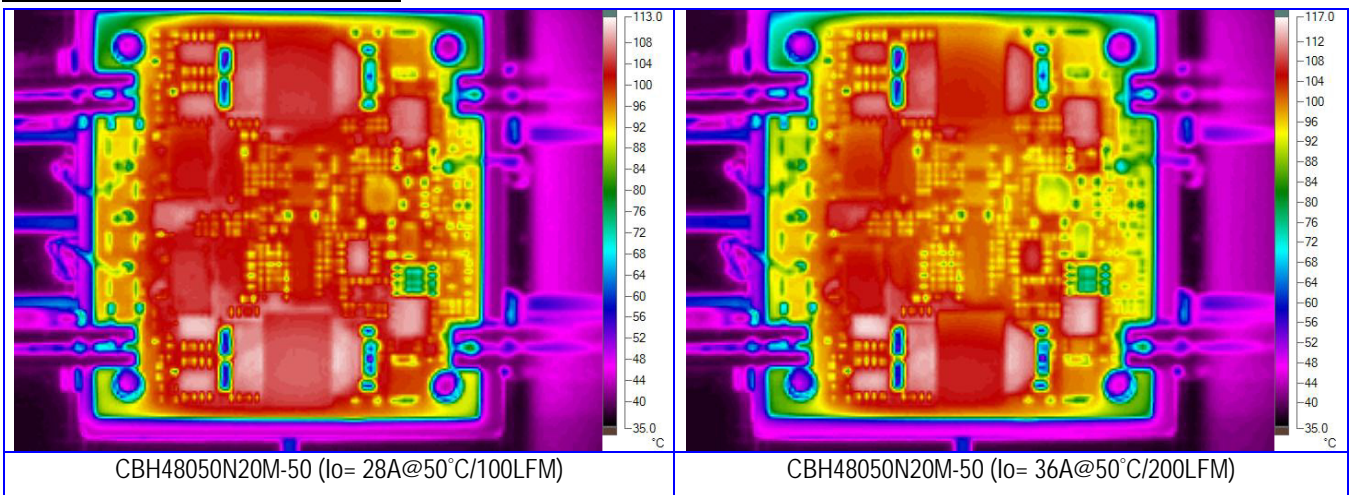

SPECIFICATIONS

Absolute Maximum Ratings		
Temperature	Operation Storage	-40°C to +110°C -55°C to +125°C
Input Voltage Range	Operation: 24V Models 48V Models Transient (100mS): 24V Models 48V Models	-0.5V to +40Vdc -0.5V to +80Vdc 50V Maximum 100V Maximum
Isolation Voltage	Input to Output Input to Case Output to Case	2.0KV Minimum 1.0KV Minimum 1.0KV Minimum
Remote Control		-0.5V to +12Vdc

General Parameters		
Conversion Efficiency	Typical	See table
Switching Frequency	Typical	330KHz
MTBF	Bellcore TR-332 issue 6	3.30x10 ⁶ hrs @GB/25°C (CBH48050abcd-50XXX)
OTP	Internal	110°C(Tc) ±5°C
Weight	Open frame Metallic enclosure	60g / 1.0mm metal plate 95g / 1.0mm metal plate

Control Functions		
Remote Control	Logic High Logic Low	+3.0V to +6.5V 0V to +1.0V
Input Current of Remote Control Pin		-0.5mA ~ +1.5mA

Input		
Operation Voltage Range	24V Models 48V Models	+18V to +36Vdc +36V to +75Vdc
Reflected Ripple Current	L _{EXT} = 10uH	30mA rms/100mAp-p
Power ON Voltage Ranges	24V Models 48V Models	+17.0V to +18.0Vdc +34.0V to +36.0Vdc
Power OFF Voltage Ranges	24V Models 48V Models	+15.6V to +16.6Vdc +31.2V to +33.2Vdc
Off State Input Current	V _{NOM}	6mA Max
Latch-State Input Current	V _{NOM}	8mA Max
Input Capacitance	24V Models 48V Models	42.0uF Max 15.0uF Max

Output		
Voltage Accuracy	Typical	±1.0%
Line Regulation	Full Input Range	±0.3%
Load Regulation	0%~100%	±0.3%
Temperature Drift	-40°C ~100°C	±0.03%/°C
Output Tolerance Band	All Conditions	±4%
Ripple & Noise (20MHz)	Peak-Peak (RMS)	3% (1%) V _O
Over Voltage Protection	V _{NOM} , 10% Load	115~130 %V _O
Output Current Limits	V _{NOM}	108%~125%
Voltage Trim	V _{NOM} , 10% Load	±10%
Input Ripple Rejection (<1KHz)	V _{NOM} , Full Load	-50dB
Step Load (2.5A/μS)	50%~75% Load	±6%Vo/500μS
Start-Up Delay Time	V _{NOM} , Full Load	20mS/250mS

TYPICAL WAVES AND CURVES

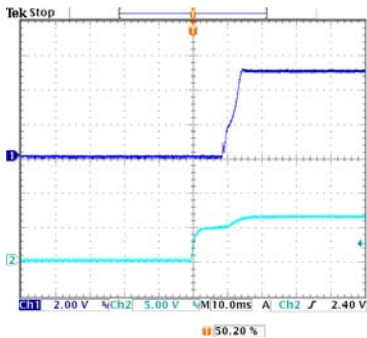

Start-up waveform of CBH24050abcd-50XXX
(V_{IN} : 24V, Load: 50A)

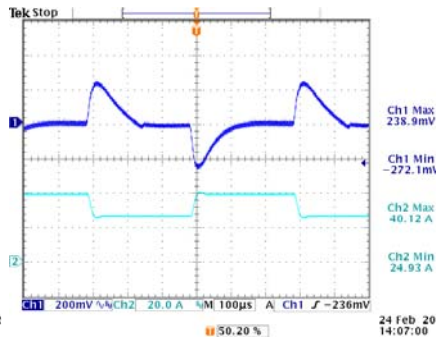

Transient response of CBH24050abcd-50XXX
(V_{IN} : 24V, Load: 39A/24A@2.5A/µs)

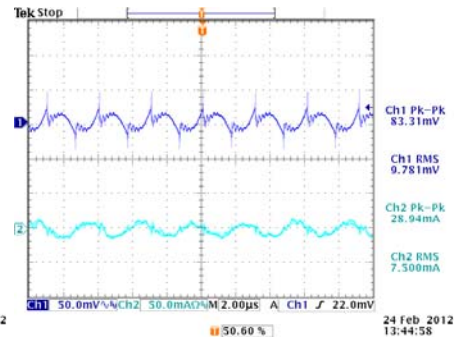

Input/Output ripples of CBH24050abcd-50XXX
(V_{IN} : 24V, Load: 50A, L_{IN} =10µH)

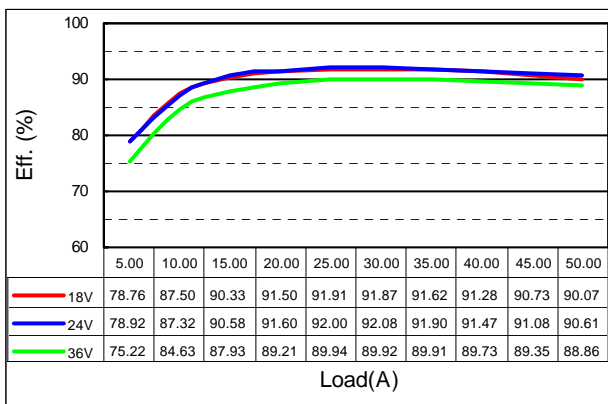

Efficiency plot of CBH24050abcA-50XXX

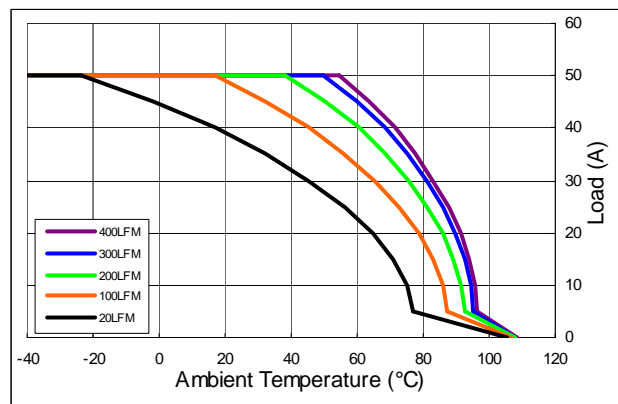

Derating curves of CBH24050abcA-50XXX for $T_C = 110^\circ\text{C}$

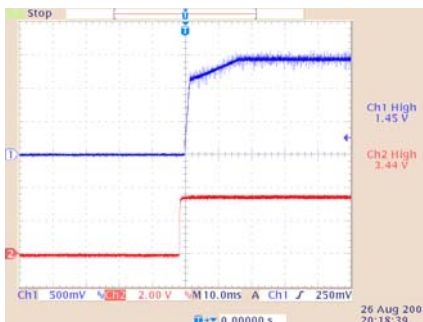

Start-up waveform of CBH48015abcd-60XXX
(V_{IN} : 48V, Load: 60A)

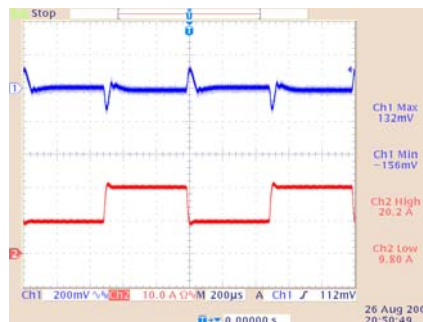

Transient response of CBH48015abcd-60XXX
(V_{IN} : 48V, Load: 20A/10A@2.5A/µs)

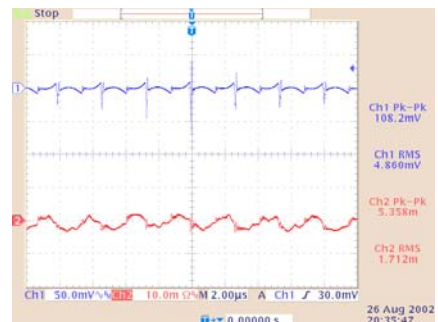

Input/Output ripples of CBH48015abcd-60XXX
(V_{IN} : 48V, Load: 60A, L_{IN} =10µH)

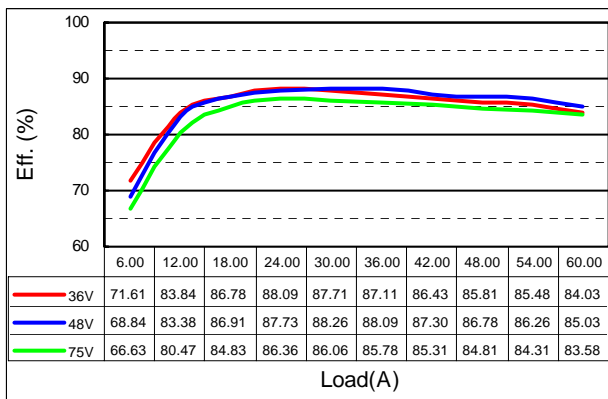

Efficiency plot of CBH48015abcA-60XXX

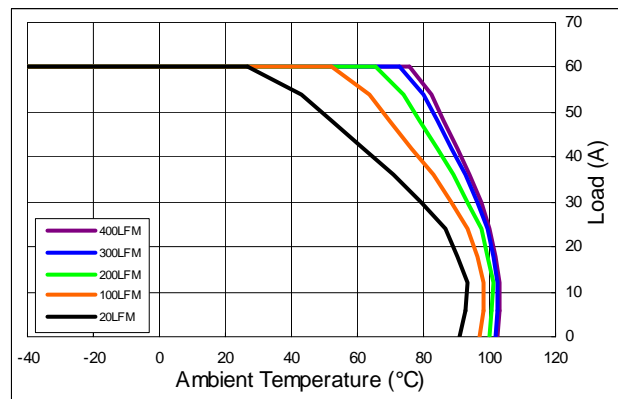

Derating curves of CBH48015abcA-60XXX for $T_C = 110^\circ\text{C}$

METAL ENCLOSED PACKAGE

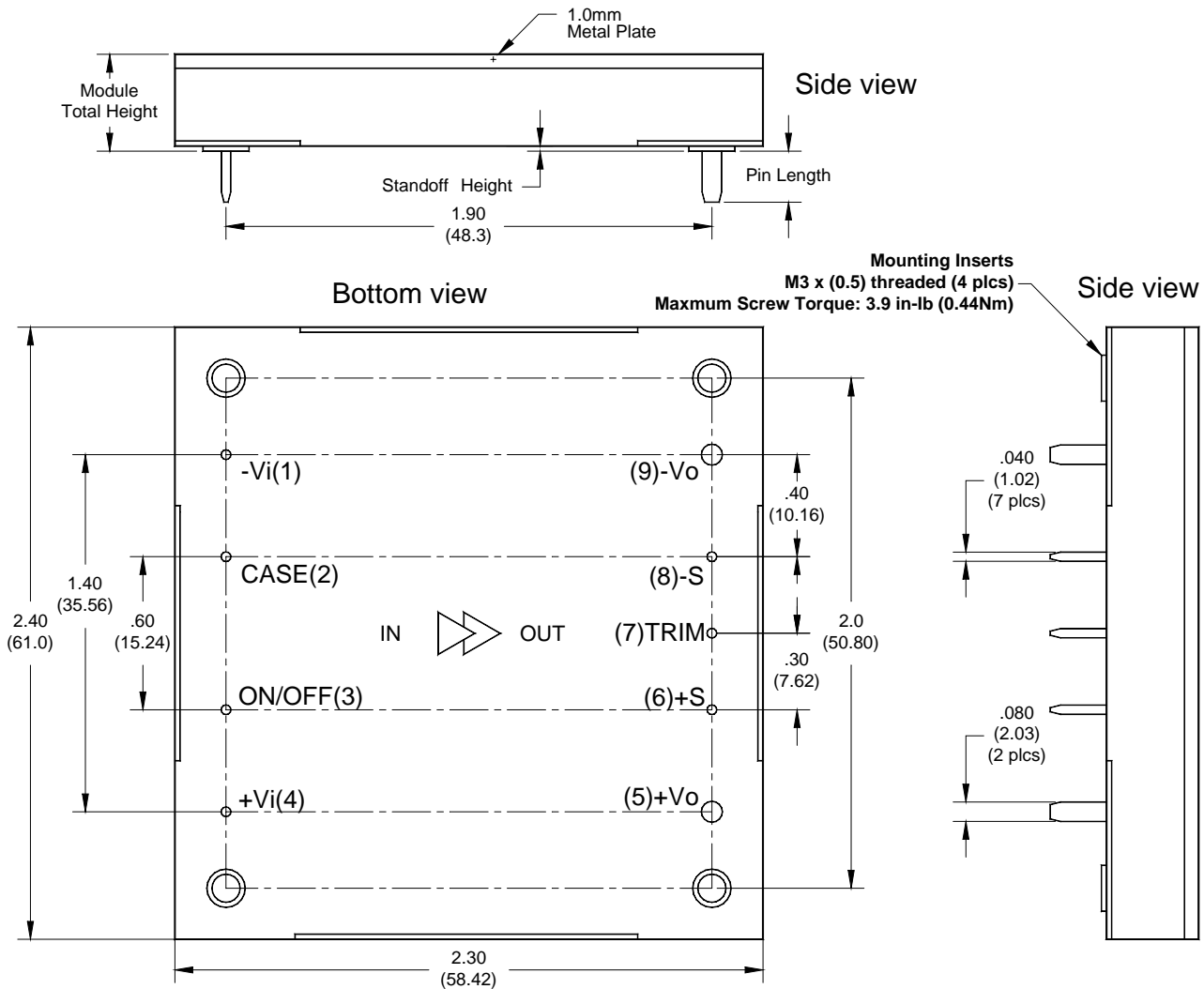

Dimensions and Pin Connections

Designation	Function Description	Pin #
-Vi	Negative input	1
CASE	Connected to base plate	2
ON/OFF	Remote control. To turn-on and turn-off output.	3
+Vi	Positive input	4
+Vo	Positive output	5
+S	Positive remote sense	6
TRIM	Output voltage adjust	7
-S	Negative remote sense	8
-Vo	Negative output	9

Dimensions: inches (mm)

Tolerances: .xx±0.02 (.x±0.5)
.xxx±0.01 (.x±0.25)

Weight: 95g / 1.0mm metal plate

Base plate: Aluminum alloy with anode oxide

Mounting inserts: Stainless steel

Maximum torque: 3.9 in-lb (0.44Nm)

Pin material: Copper alloy or Brass

Pin plating: Golden over Nickel

OPEN FRAME PACKAGE

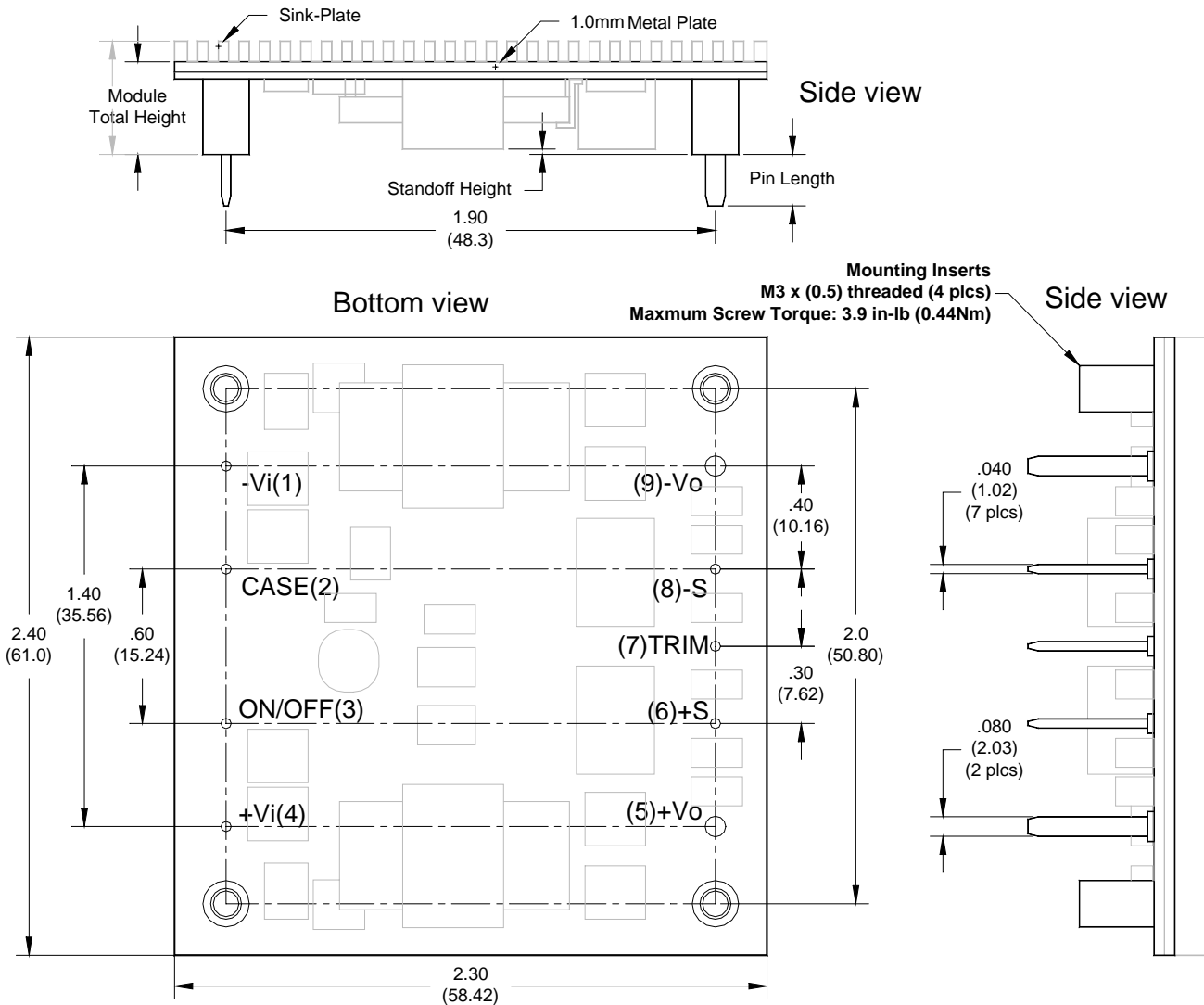

Dimensions and Pin Connections

Designation	Function Description	Pin #
-Vi	Negative input	1
CASE	Connected to base plate	2
ON/OFF	Remote control. To turn-on and turn-off output.	3
+Vi	Positive input	4
+Vo	Positive output	5
+S	Positive remote sense	6
TRIM	Output voltage adjust	7
-S	Negative remote sense	8
-Vo	Negative output	9

Dimensions: inches (mm)

Tolerances: .xx±0.02 (.x±0.5)
.xxx±0.01 (.x±0.25)

Weight: 60g / 1.0mm metal plate

Base plate: Aluminum alloy with anode oxide

Mounting inserts: Stainless steel

Maximum torque: 3.9 in-lb (0.44Nm)

Pin material: Copper alloy or Brass

Pin plating: Golden over Nickel

REFERENCED EMC CIRCUIT

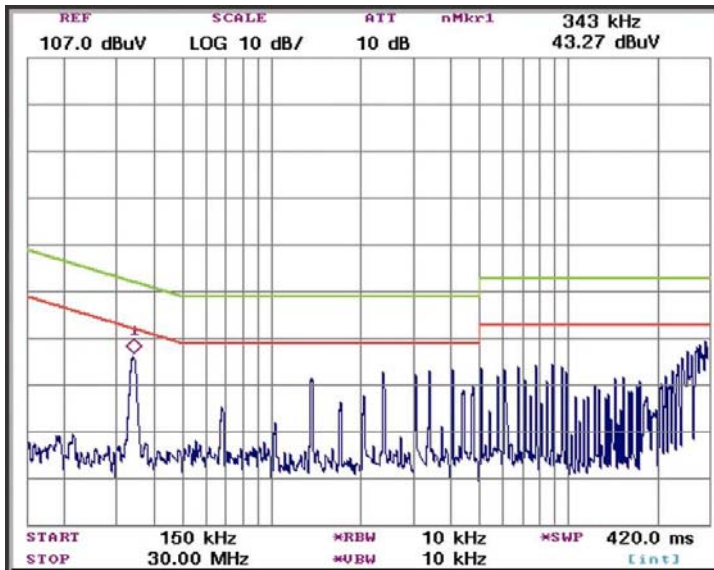

Referenced EMC Performance

The tested result shown in left-hand side is obtained by loading the power module with a resistive load only. It can be used as a design reference for customer system. However! The performance of customer’s system depends on the whole system design. It should be noted that modifications on the circuit parameters and fine adjustment of the final layout affect the final EMC performance greatly.

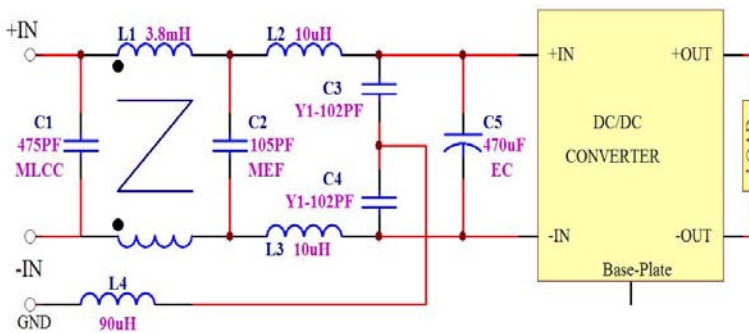

Bandwidth of EMC Components

No components are ideal for infinite frequency range. The bandwidth of EMC components should be taking into consideration when designing an EMC filter circuit. To connect ceramic capacitor with electricity capacitor in parallel and connect low inductance inductor with big one could get a better bandwidth.

Measured conductive level of CBH48050abcd-50XXX and referenced filter circuit

NOTE:

1. It is recommended that the input should be protected by fuses or other protection devices.
2. All specifications are typical at nominal input, full load and 25°C unless otherwise noted.
3. Specifications are subject to change without notice.
4. Printed or downloaded datasheets are not subject to Glary document control.
5. Product labels shown, including safety agency certificates, may vary based on the date of manufacture.
6. Information provided in this documentation is for ordering purposes only.
7. This product is not designed for use in critical life support systems, equipment used in hazardous environments, nuclear control systems or other such applications, which necessitate specific safety and regulatory standards other than the ones listed in this datasheet.

IMPORTANT

- ✳ General specifications and the performances are related to standard series only, no special customer specification display here except requested items.
- ✳ In order to secure effective usage of converter and the validity of Glary’s service and warranty coverage, please refer to the application notes for general usage. For needs of usage beyond the application notes, please contact to Glary headquarter or our regional sales representative office for help.

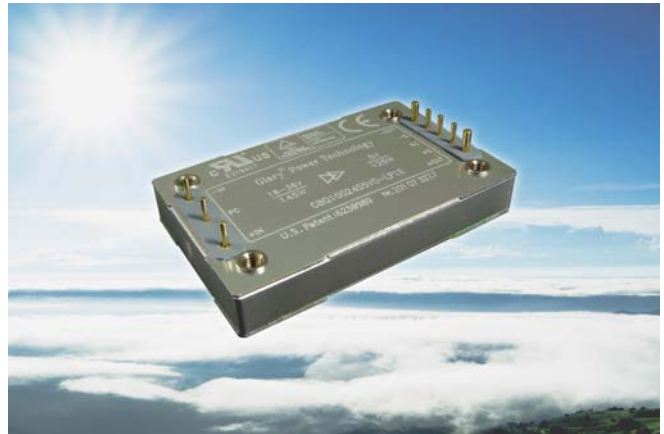

The **Enclosed CBQ** series provides up to 125W/25A outputs with six-sides metal package. The efficient SR stage is combined with patented "Buck Reset" topology that would reduce power loss to achieve 101W/in³ power density. The multi-layer single side circuit board design would enhance the thermal performance and improve its reliability. Modules are designed for Telecom, Servers, Networking equipments and other applications that use a 24V or 48V input bus.

PART NUMBER SYSTEM

CBQ100	48S	5V0	-L	a	b	c	XX	X
Series Name	Input Voltage	Output Voltage		Enable Logic	Pin Dimension	Base-Plate	Suffix	Version
CBQ100	48S =36V~75V 24S =18V~36V	Unit: 0.1V Increments 050 =5V 033 =3.3V	-L	P: Positive N: Negative	0 : 0.12" 1 : 0.16" 2 : 0.20" 3 : 0.24"	E : Metallic enclosure (1.0mm Metal Plate)	For marketing purpose only	

MODEL LIST (Contact to factory for special input / output)

Part Number *	Maximum Input		Maximum Output		Efficiency	Part Number *	Maximum Input		Maximum Output		Efficiency
CBQ10048S5V0-LabcXXX	36V~75V	139W	5.0V/25A	125W	90%	CBQ10024S5V0-LabcXXX	18V~36V	141W	5.0V/25A	125W	89%
CBQ10048S3V3-LabcXXX	36V~75V	94W	3.3V/25A	83W	89%	CBQ10024S3V3-LabcXXX	18V~36V	94W	3.3V/25A	83W	88%
CBQ10048S2V5-LabcXXX	36V~75V	73W	2.5V/25A	63W	87%	CBQ10024S2V5-LabcXXX	18V~36V	74W	2.5V/25A	63W	86%
CBQ10048S2V0-LabcXXX	36V~75V	59W	2.0V/25A	50W	85%	CBQ10024S2V0-LabcXXX	18V~36V	59W	2.0V/25A	50W	85%
CBQ10048S1V8-LabcXXX	36V~75V	53W	1.8V/25A	45W	85%	CBQ10024S1V8-LabcXXX	18V~36V	54W	1.8V/25A	45W	84%
CBQ10048S1V5-LabcXXX	36V~75V	46W	1.5V/25A	38W	83%	CBQ10024S1V5-LabcXXX	18V~36V	46W	1.5V/25A	38W	83%

REFERENCED THERMAL IMAGES

To be updated in next version	To be updated in next version
-------------------------------	-------------------------------

SPECIFICATIONS

Absolute Maximum Ratings		
Temperature	Operation Storage	-40°C to +110°C -55°C to +125°C
Input Voltage Range	Operation: 24V Models 48V Models Transient (100mS): 24V Models 48V Models	-0.5V to +40Vdc -0.5V to +80Vdc 50V Maximum 100V Maximum
Isolation Voltage	Input to Output Input to Case Output to Case	2.0KV Minimum 1.0KV Minimum 1.0KV Minimum
Remote Control		-0.5V to +12Vdc

General Parameters		
Conversion Efficiency	Typical	See table
Switching Frequency	Typical	330KHz
MTBF	Bellcore TR-332 issue 6	4.57×10 ⁶ hrs @GB/25°C (CBQ10048S5V0-LabcXXX)
OTP	Internal	110°C(Tc) ±5°C
Weight	Metallic enclosure	55g

Control Functions		
Remote Control	Logic High Logic Low	+3.0V to +6.5V 0V to +1.0V
Input Current of Remote Control Pin		-0.5mA ~ +1.5mA

Input		
Operation Voltage Range	24V Models 48V Models	+18V to +36Vdc +36V to +75Vdc
Reflected Ripple Current	L _{EXT} = 10uH	20mA rms/60mAp-p
Power ON Voltage Ranges	24V Models 48V Models	+17.0V to +18.0Vdc +34.0V to +36.0Vdc
Power OFF Voltage Ranges	24V Models 48V Models	+15.6V to +16.6Vdc +31.2V to +33.2Vdc
Off State Input Current	V _{NOM}	6mA Max
Latch-State Input Current	V _{NOM}	8mA Max
Input Capacitance	24V Models 48V Models	22.0uF Max 10.0uF Max

Output		
Voltage Accuracy	Typical	±1.0%
Line Regulation	Full Input Range	±0.3%
Load Regulation	0%~100%	±0.3%
Temperature Drift	-40°C ~100°C	±0.03%/°C
Output Tolerance Band	All Conditions	±4%
Ripple & Noise (20MHz)	Peak-Peak (RMS)	3% (1%) V _O
Over Voltage Protection	V _{NOM} , 10% Load	115~130 %V _O
Output Current Limits	V _{NOM}	108%~125%
Voltage Trim	V _{NOM} , 10% Load	±10%
Input Ripple Rejection (<1KHz)	V _{NOM} , Full Load	-50dB
Step Load (2.5A/μS)	50%~75% Load	±6%Vo/500μS
Start-Up Delay Time	V _{NOM} , Full Load	20mS/250mS

TYPICAL WAVES AND CURVES

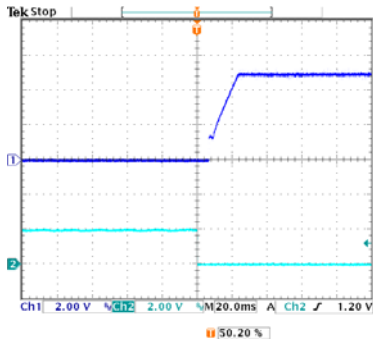

Start-up waveform of CBQ10048S5V0-LabcXXX
(V_{IN} : 48V, Load: 25A)

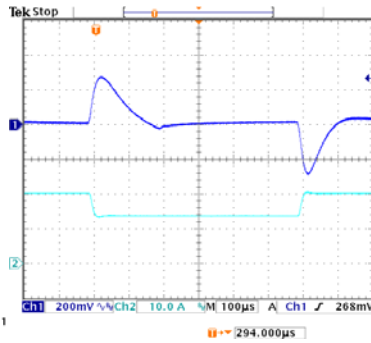

Transient response of CBQ10048S5V0-LabcXXX
(V_{IN} : 48V, Load: 20.5A/13.0A@2.5A/µs)

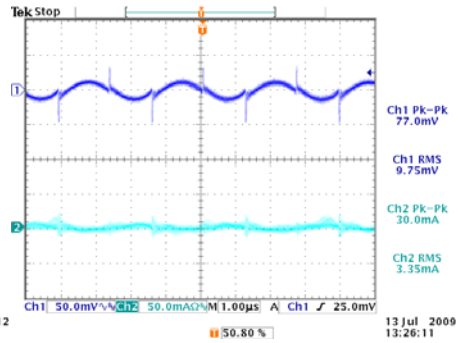

Input/Output ripples of CBQ10048S5V0-LabcXXX
(V_{IN} : 48V, Load: 25A, L_{IN} =10uH, C_{IN} =100uH)

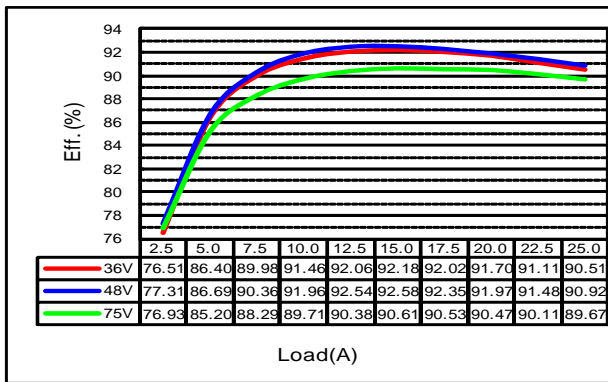

Efficiency plot of CBQ10048S5V0-LabcXXX

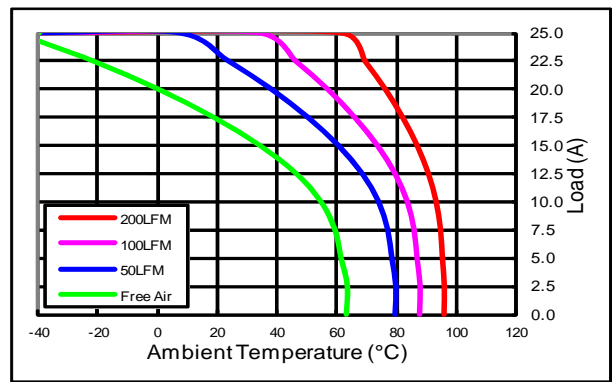

Derating curves of CBQ10048S5V0-LabcXXX for $T_c = 110^\circ\text{C}$

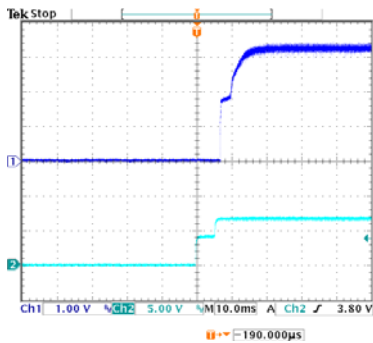

Start-up waveform of CBQ10024S3V3-LabcXXX
(V_{IN} : 24V, Load: 25A)

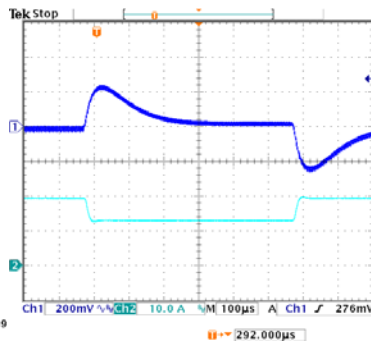

Transient response of CBQ10024S3V3-LabcXXX
(V_{IN} : 24V, Load: 20A/12.5A@2.5A/µs)

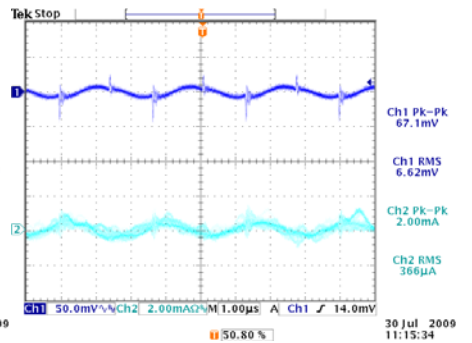

Input/Output ripples of CBQ10024S3V3-LabcXXX
(V_{IN} : 24V, Load: 25A, L_{IN} =10uH)

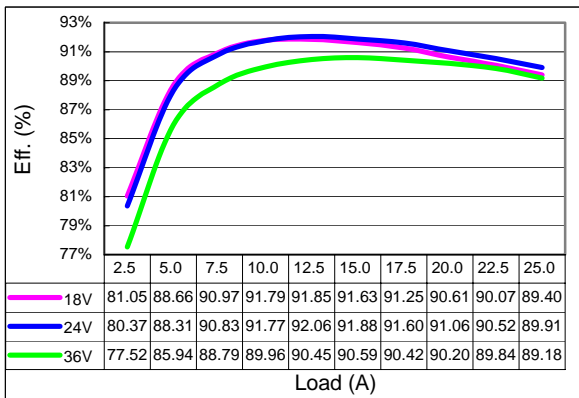

Efficiency plot of CBQ10024S3V3-LabcXXX

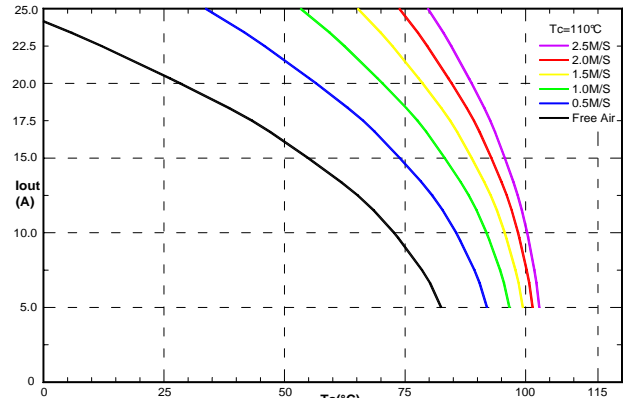

Derating curves of CBQ10024S3V3-LabcXXX

METAL ENCLOSED PACKAGE

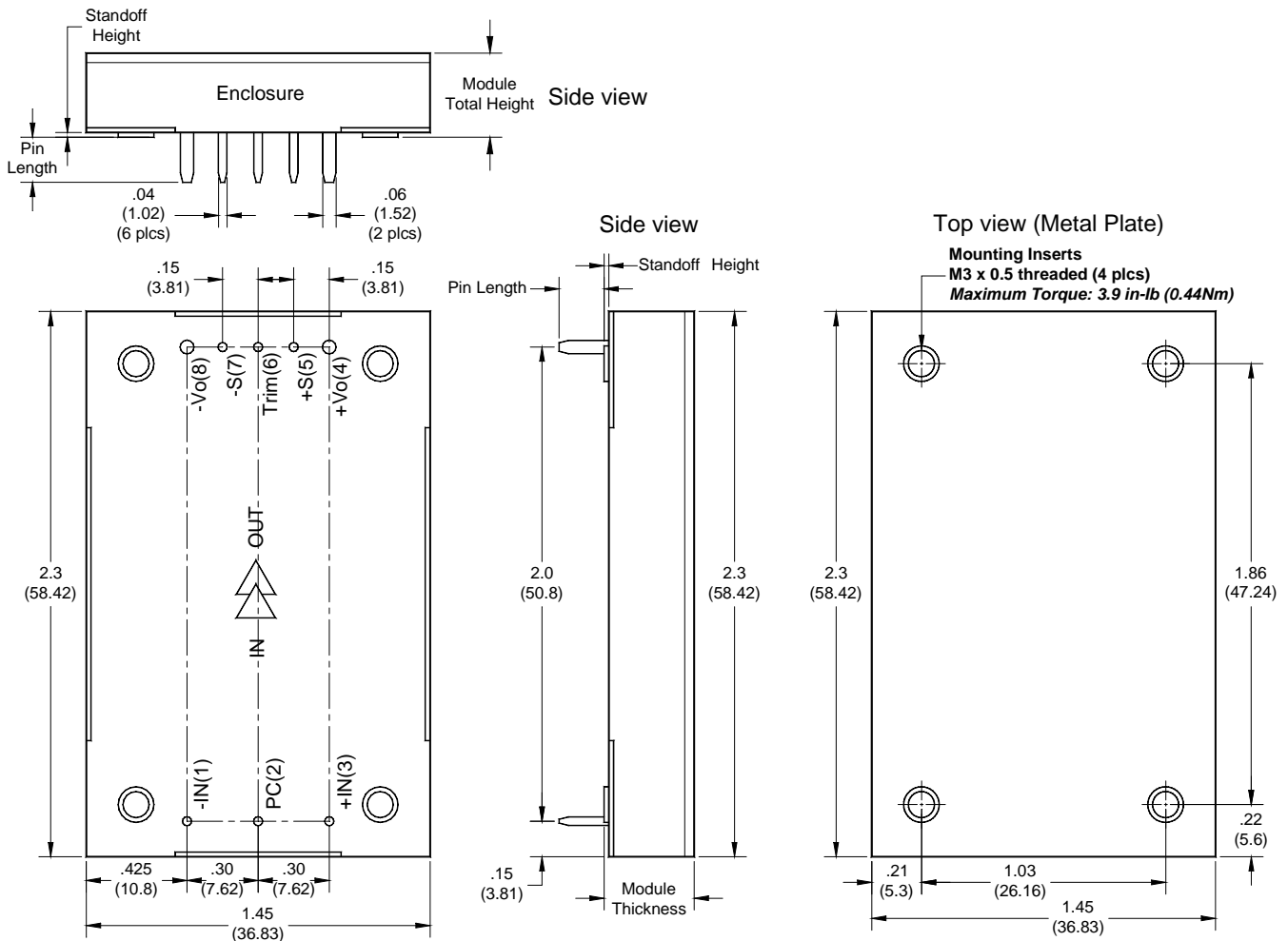

Dimensions and Pin Connections

Designation	Function Description	Pin #
-IN	Negative input	1
PC	Remote control. To turn-on and turn-off output.	2
+IN	Positive input	3
+Vo	Positive output	4
+S	Positive remote sense	5
TRIM	Output voltage adjust	6
-S	Negative remote sense	7
-Vo	Negative output	8

Dimensions: inches (mm)

Tolerances: .xx±0.02 (.x±0.5)
.xxx±0.01 (.x±0.25)

Weight: 55g

Base plate: Aluminum alloy with anode oxide

Mounting inserts: Stainless steel
Maximum torque: 3.9 in-lb (0.44Nm)

Pin material: Copper alloy or Brass

Pin plating: Golden over Nickel

REFERENCED EMC CIRCUIT

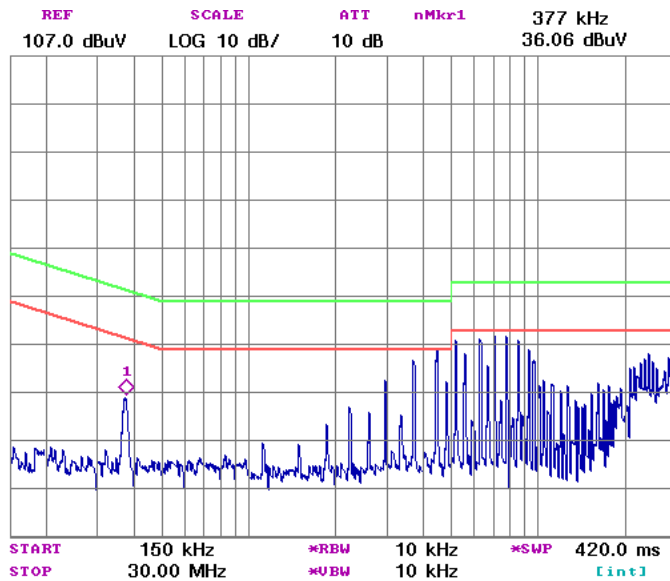

Referenced EMC Performance

The tested result shown in left-hand side is obtained by loading the power module with a resistive load only. It can be used as a design reference for customer system. However! The performance of customer's system depends on the whole system design. It should be noted that modifications on the circuit parameters and fine adjustment of the final layout affect the final EMC performance greatly.

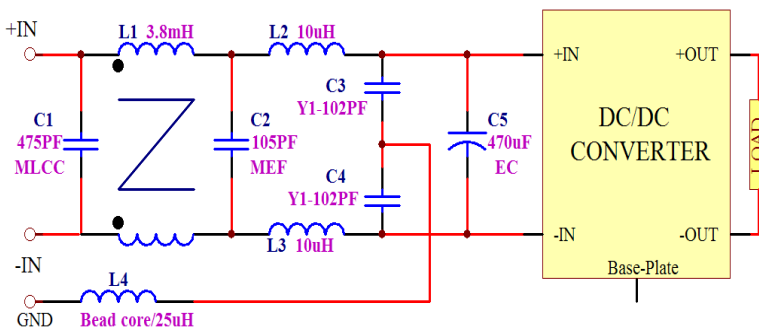

Bandwidth of EMC Components

No components are ideal for infinite frequency range. The bandwidth of EMC components should be taking into consideration when designing an EMC filter circuit. To connect ceramic capacitor with electricity capacitor in parallel and connect low inductance inductor with big one could get a better bandwidth.

Measured conductive level of CBQ10048S5V0-LabcXXX and referenced filter circuit

NOTE:

1. It is recommended that the input should be protected by fuses or other protection devices.
2. All specifications are typical at nominal input, full load and 25°C unless otherwise noted.
3. Specifications are subject to change without notice.
4. Printed or downloaded datasheets are not subject to Glary document control.
5. Product labels shown, including safety agency certificates, may vary based on the date of manufacture.
6. Information provided in this documentation is for ordering purposes only.
7. This product is not designed for use in critical life support systems, equipment used in hazardous environments, nuclear control systems or other such applications, which necessitate specific safety and regulatory standards other than the ones listed in this datasheet.

IMPORTANT

- ✘ General specifications and the performances are related to standard series only, no special customer specification display here except requested items.
- ✘ In order to secure effective usage of converter and the validity of Glary's service and warranty coverage, please refer to the application notes for general usage. For needs of usage beyond the application notes, please contact to Glary headquarter or our regional sales representative office for help.



The **Enclosed COE** series provides up to 130W/50A outputs with industry standard eighth brick pin assignment. The high thermal conductivity silicone potted six-sides metal package is designed for applications under extreme environmental conditions. The efficient SR stage is combined with patented “Buck Reset” topology that would reduce power loss to achieve 102W/in³ power density. The multi-layer single side circuit board design plus the metal-plate technology would enhance the thermal performance and improve its reliability. Modules are designed for Telecom, Servers, Networking equipments and other applications that use a 24V or 48V input bus.

PART NUMBER SYSTEM

COE	48	120	a	b	c	d	-	11	XX	X
Series Name	Input Voltage	Output Voltage	Enable Logic	Pin Dimension	Standoff Height	Base-Plate		Output Current	Suffix	Version
COE	48=36V~75V 24=18V~36V	Unit: 0.1V Increments 120=12V 050=5V	P: Positive N: Negative	0 : 0.12" 1 : 0.16" 2 : 0.20" 3 : 0.24"	0 : 0.02"	U : 3.0mm Metal Plate V : 5.0mm Metal Plate W : 3.0mm Sink Plate	-	00~50 : For output current rating	For marketing purpose only	

MODEL LIST (Contact to factory for special input / output)

Part Number *	Maximum Input		Maximum Output		Efficiency	Part Number *	Maximum Input		Maximum Output		Efficiency
COE48120abcd-11XXX	36V~75V	145W	12.0V/11A	132W	92%	COE24120abcd-10XXX	18V~36V	133W	12.0V/10A	120W	92%
COE48070abcd-18XXX	36V~75V	138W	7.0V/18A	126W	91%	COE24050abcd-25XXX	18V~36V	139W	5.0V/25A	125W	91%
COE48050abcd-25XXX	36V~75V	138W	5.0V/25A	125W	91%	COE24033abcd-30XXX	18V~36V	111W	3.3V/30A	99W	90%
COE48033abcd-30XXX	36V~75V	111W	3.3V/30A	99W	90%	COE24025abcd-40XXX	18V~36V	114W	2.5V/40A	100W	89%
COE48025abcd-40XXX	36V~75V	114W	2.5V/40A	100W	89%	COE24018abcd-50XXX	18V~36V	106W	1.8V/50A	90W	87%
COE48018abcd-50XXX	36V~75V	106W	1.8V/50A	90W	87%	COE24015abcd-50XXX	18V~36V	90W	1.5V/50A	75W	85%
COE48015abcd-50XXX	36V~75V	90W	1.5V/50A	75W	85%						

REFERENCED THERMAL IMAGES

To be updated in next version	To be updated in next version
-------------------------------	-------------------------------

Enclosed COE Series

SPECIFICATIONS

Absolute Maximum Ratings		
Temperature	Operation Storage	-40°C to +110°C -55°C to +125°C
Input Voltage Range	Operation: 24V Models 48V Models Transient (100mS): 24V Models 48V Models	-0.5V to +40Vdc -0.5V to +80Vdc 50V Maximum 100V Maximum
Isolation Voltage	Input to Output Input to Case Output to Case	2.0KV Minimum 1.0KV Minimum 1.0KV Minimum
Remote Control		-0.5V to +12Vdc

General Parameters		
Conversion Efficiency	Typical	See table
Switching Frequency	Typical	330KHz
MTBF	Bellcore TR-332 issue 6	4.80x10 ⁶ hrs @GB/25°C (COE48050abcc-25XXX)
OTP	Internal	110°C(Tc) ±5°C
Weight	3.0mm metal plate 5.0mm metal plate	55g 65g

Control Functions		
Remote Control	Logic High Logic Low	+3.0V to +6.5V 0V to +1.0V
Input Current of Remote Control Pin		-0.5mA ~ +1.5mA

Input		
Operation Voltage Range	24V Models 48V Models	+18V to +36Vdc +36V to +75Vdc
Reflected Ripple Current	L _{EXT} = 10uH	20mA rms/60mAp-p
Power ON Voltage Ranges	24V Models 48V Models	+17.0V to +18.0Vdc +34.0V to +36.0Vdc
Power OFF Voltage Ranges	24V Models 48V Models	+15.6V to +16.6Vdc +31.2V to +33.2Vdc
Off State Input Current	V _{NOM}	6mA Max
Latch-State Input Current	V _{NOM}	8mA Max
Input Capacitance	24V Models 48V Models	22.0uF Max 10.0uF Max

Output		
Voltage Accuracy	Typical	±1.0%
Line Regulation	Full Input Range	±0.2%
Load Regulation	0%~100%	±0.2%
Temperature Drift	-40°C ~100°C	±0.03%/°C
Output Tolerance Band	All Conditions	±4%
Ripple & Noise (20MHz)	Peak-Peak (RMS)	3% (1%) V _O
Over Voltage Protection	V _{NOM} , 10% Load	115~130 %V _O
Output Current Limits	V _{NOM}	108%~125%
Voltage Trim	V _{NOM} , 10% Load	±10%
Input Ripple Rejection (<1KHz)	V _{NOM} , Full Load	-50dB
Step Load (2.5A/μS)	50%~75% Load	±6%Vo/500μS
Start-Up Delay Time	V _{NOM} , Full Load	20mS/250mS

TYPICAL WAVES AND CURVES

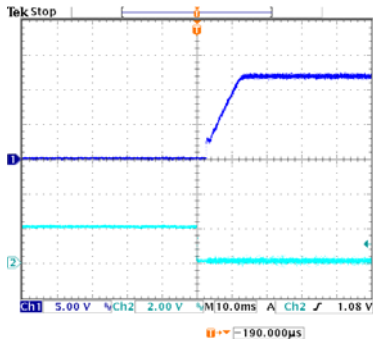

Start-up waveform of COE48120abcd-11XXX
(V_{IN} : 48V, Load: 11A)

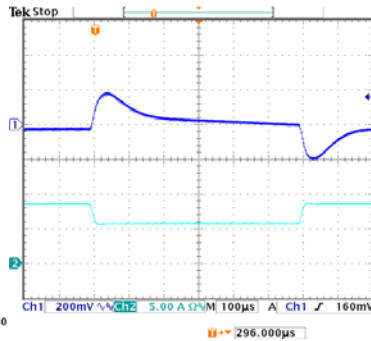

Transient response of COE48120abcd-11XXX
(V_{IN} : 48V, Load: 8.5A/5.5A@2.5A/µs)

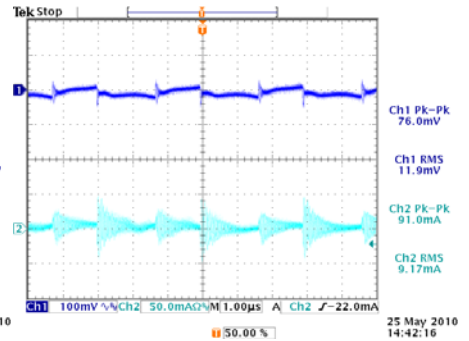

Input/Output ripples of COE48120abcd-11XXX
(V_{IN} : 48V, Load: 11A, L_{IN} =10uH)

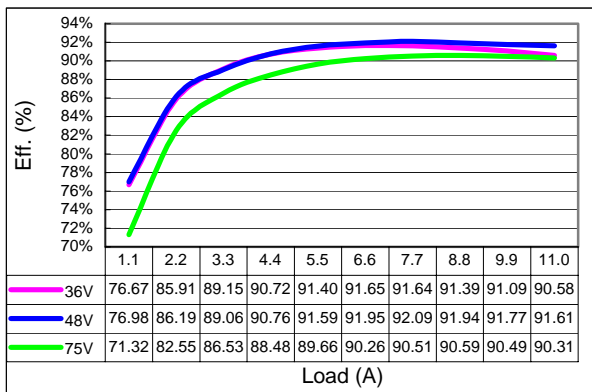

Efficiency plot of COE48120abcA-11XXX

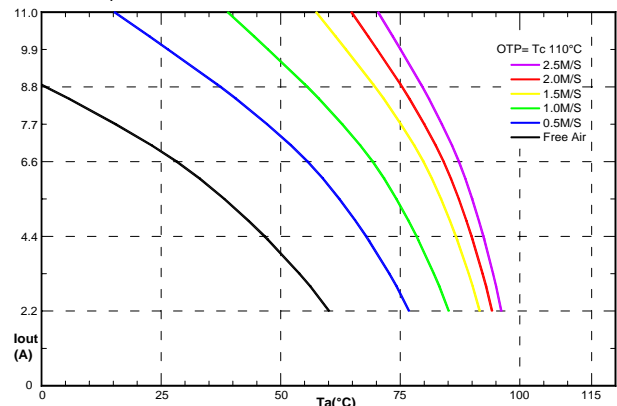

Derating curves of COE48120abcA-11XXX for $T_C = 110^\circ\text{C}$

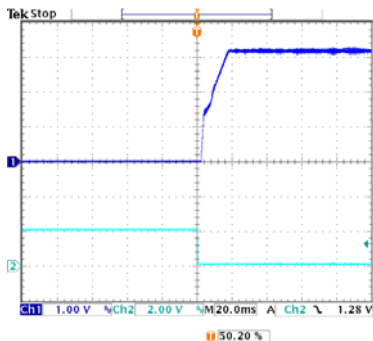

Start-up waveform of COE48033abcd-30XXX
(V_{IN} : 48V, Load: 30A)

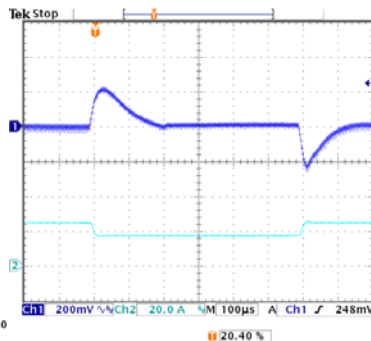

Transient response of COE48033abcd-30XXX
(V_{IN} : 48V, Load: 25A/16A@2.5A/µs)

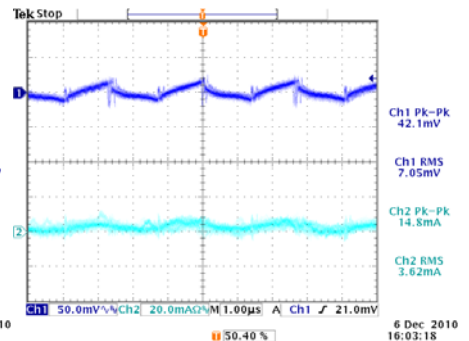

Input/Output ripples of COE48033abcd-30XXX
(V_{IN} : 48V, Load: 30A, L_{IN} =10uH)

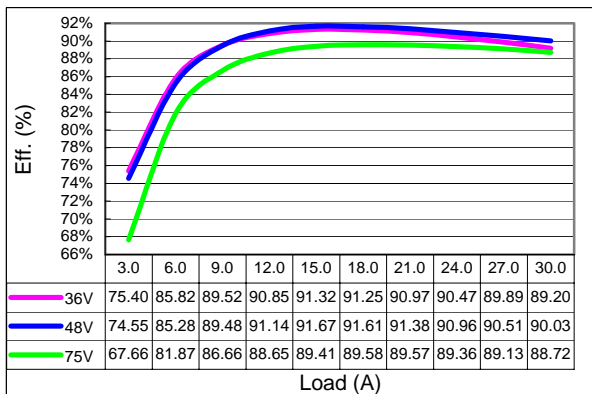

Efficiency plot of COE48033abcA-30XXX

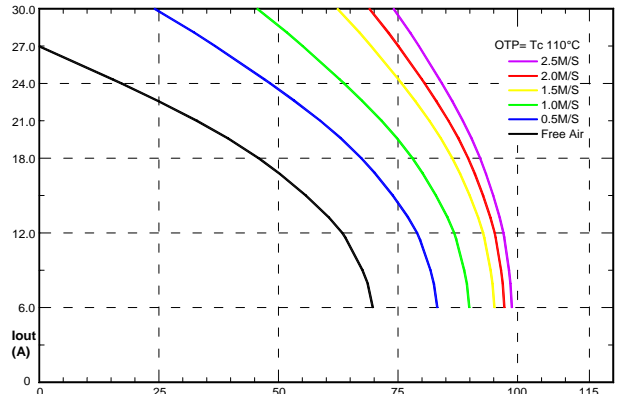

Derating curves of COE48033abcA-30XXX for $T_C = 110^\circ\text{C}$

METAL ENCLOSED PACKAGE

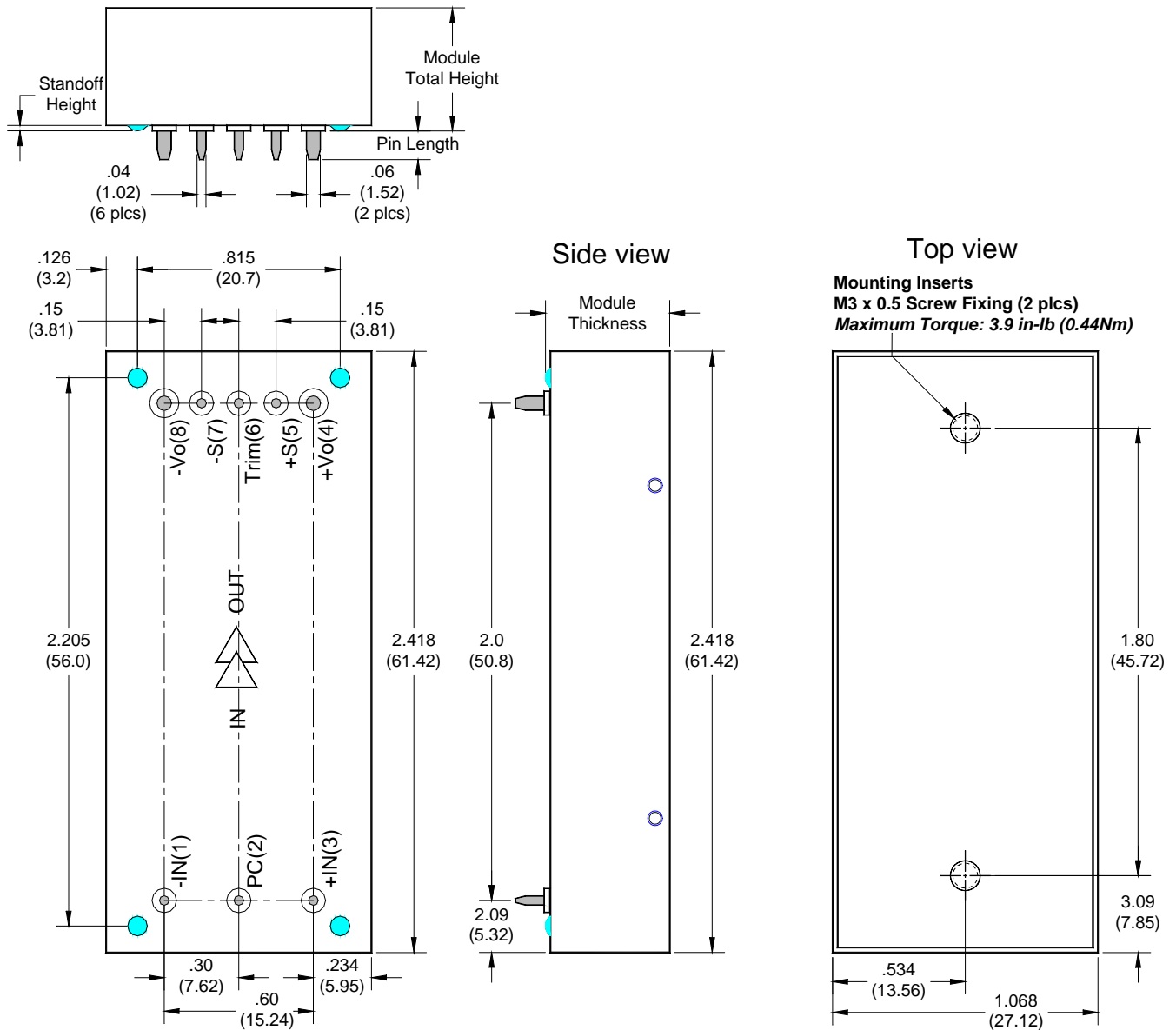

Dimensions and Pin Connections

Designation	Function Description	Pin #
-IN	Negative input	1
PC	Remote control. To turn-on and turn-off output.	2
+IN	Positive input	3
+Vo	Positive output	4
+S	Positive remote sense	5
TRIM	Output voltage adjust	6
-S	Negative remote sense	7
-Vo	Negative output	8

Dimensions: inches (mm)

Tolerances: .xx±0.02 (.x±0.5)

.xxx±0.01 (.x±0.25)

Weight: 55g / 3.0mm metal plate

65g / 5.0mm metal plate

Base plate: Aluminum alloy with anode oxide

Mounting inserts: Stainless steel

Maximum torque: 3.9 in-lb (0.44Nm)

Pin material: Copper alloy or Brass

Pin plating: Golden over Nickel

REFERENCED EMC CIRCUIT

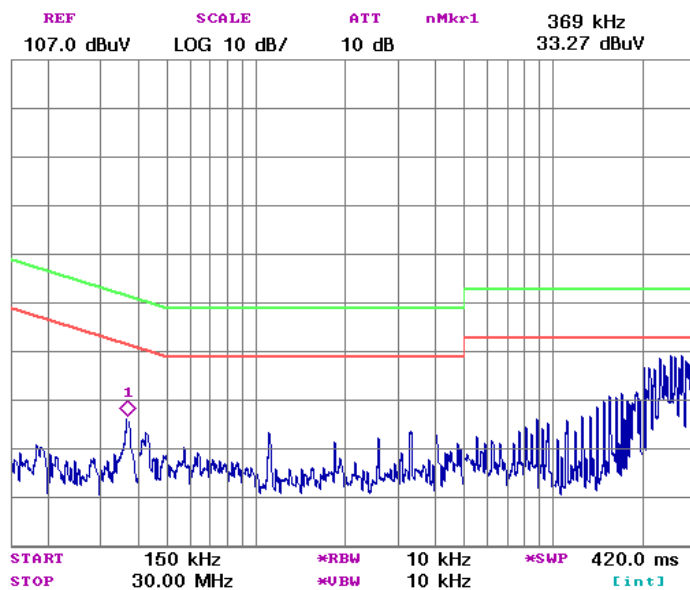

Referenced EMC Performance

The tested result shown in left-hand side is obtained by loading the power module with a resistive load only. It can be used as a design reference for customer system. However! The performance of customer's system depends on the whole system design. It should be noted that modifications on the circuit parameters and fine adjustment of the final layout affect the final EMC performance greatly.

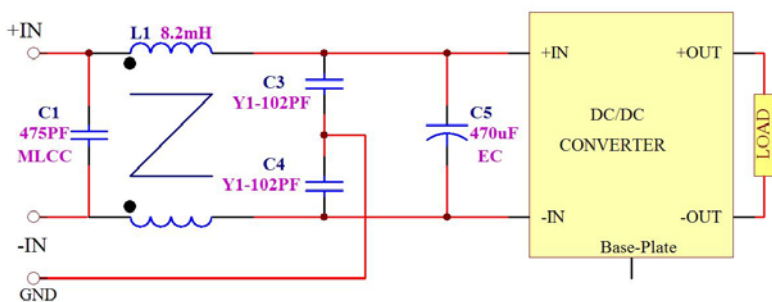

Measured conductive level of COE48050abcd-25XXX and referenced filter circuit

Bandwidth of EMC Components

No components are ideal for infinite frequency range. The bandwidth of EMC components should be taking into consideration when designing an EMC filter circuit. To connect ceramic capacitor with electricity capacitor in parallel and connect low inductance inductor with big one could get a better bandwidth.

NOTE:

1. It is recommended that the input should be protected by fuses or other protection devices.
2. All specifications are typical at nominal input, full load and 25°C unless otherwise noted.
3. Specifications are subject to change without notice.
4. Printed or downloaded datasheets are not subject to Glary document control.
5. Product labels shown, including safety agency certificates, may vary based on the date of manufacture.
6. Information provided in this documentation is for ordering purposes only.
7. This product is not designed for use in critical life support systems, equipment used in hazardous environments, nuclear control systems or other such applications, which necessitate specific safety and regulatory standards other than the ones listed in this datasheet.

IMPORTANT

- ✳ General specifications and the performances are related to standard series only, no special customer specification display here except requested items.
- ✳ In order to secure effective usage of converter and the validity of Glary's service and warranty coverage, please refer to the application notes for general usage. For needs of usage beyond the application notes, please contact to Glary headquarter or our regional sales representative office for help.



The **COE** series provides up to 132W/50A outputs with industry standard eighth brick pin assignment. The efficient SR stage is combined with patented "Buck Reset" topology that would reduce power loss to achieve 175W/in³ power density. The multi-layer single side circuit board design plus the Sink-plate technology would enhance the thermal performance and improve its reliability. Modules are designed for Telecom, Servers, Networking equipments and other applications that use a 24V or 48V input bus.

PART NUMBER SYSTEM

COE	48	120	a	b	c	d	-	11	XX	X
Series Name	Input Voltage	Output Voltage	Enable Logic	Pin Dimension	Standoff Height	Base-Plate		Output Current	Suffix	Version
COE	48=36V~75V 24=18V~36V	Unit: 0.1V Increments 120=12V 050=5V	P: Positive N: Negative	0 : 0.12" 1 : 0.16" 2 : 0.20" 3 : 0.24"	0 : 0.02" 1 : 0.08" 2 : 0.16"	M : 1.0mm Metal Plate S : 3.0mm Metal Plate A : 3.0mm Sink-Plate B : 5.0mm Sink-Plate		00~50 : For output current rating	For marketing purpose only	

MODEL LIST (Contact to factory for special input / output)

Part Number *	Maximum Input	Maximum Output	Efficiency	Part Number *	Maximum Input	Maximum Output	Efficiency
COE48120abcd-11XXX	36V~75V 145W	12.0V/11A 132W	92%	COE24120abcd-10XXX	18V~36V 133W	12.0V/10A 120W	92%
COE48070abcd-18XXX	36V~75V 138W	7.0V/18A 126W	91%	COE24050abcd-25XXX	18V~36V 139W	5.0V/25A 125W	91%
COE48050abcd-25XXX	36V~75V 138W	5.0V/25A 125W	91%	COE24033abcd-30XXX	18V~36V 111W	3.3V/30A 99W	90%
COE48033abcd-30XXX	36V~75V 111W	3.3V/30A 99W	90%	COE24025abcd-40XXX	18V~36V 114W	2.5V/40A 100W	89%
COE48025abcd-40XXX	36V~75V 114W	2.5V/40A 100W	89%	COE24018abcd-50XXX	18V~36V 106W	1.8V/50A 90W	87%
COE48018abcd-50XXX	36V~75V 106W	1.8V/50A 90W	87%	COE24015abcd-50XXX	18V~36V 90W	1.5V/50A 75W	85%
COE48015abcd-50XXX	36V~75V 90W	1.5V/50A 75W	85%				

REFERENCED THERMAL IMAGES

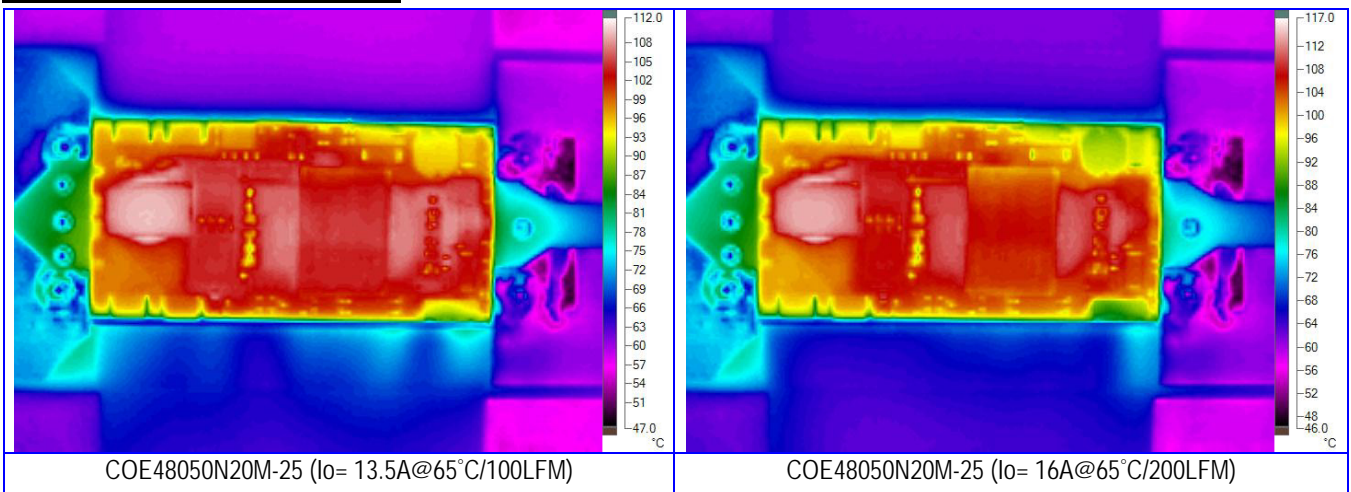

SPECIFICATIONS

Absolute Maximum Ratings		
Temperature	Operation Storage	-40°C to +110°C -55°C to +125°C
Input Voltage Range	Operation: 24V Models 48V Models Transient (100mS): 24V Models 48V Models	-0.5V to +40Vdc -0.5V to +80Vdc 50V Maximum 100V Maximum
Isolation Voltage	Input to Output Input to Case Output to Case	2.0KV Minimum 1.0KV Minimum 1.0KV Minimum
Remote Control		-0.5V to +12Vdc

General Parameters		
Conversion Efficiency	Typical	See table
Switching Frequency	Typical	330KHz
MTBF	Bellcore TR-332 issue 6	4.80x10 ⁶ hrs @GB/25°C (COE48050abcc-25XXX)
OTP	Internal	110°C(Tc) ±5°C
Weight	1.0mm metal plate 3.0mm metal plate	27g 32g

Control Functions		
Remote Control	Logic High Logic Low	+3.0V to +6.5V 0V to +1.0V
Input Current of Remote Control Pin		-0.5mA ~ +1.5mA

Input		
Operation Voltage Range	24V Models 48V Models	+18V to +36Vdc +36V to +75Vdc
Reflected Ripple Current	L _{EXT} = 10uH	20mA rms/60mAp-p
Power ON Voltage Ranges	24V Models 48V Models	+17.0V to +18.0Vdc +34.0V to +36.0Vdc
Power OFF Voltage Ranges	24V Models 48V Models	+15.6V to +16.6Vdc +31.2V to +33.2Vdc
Off State Input Current	V _{NOM}	6mA Max
Latch-State Input Current	V _{NOM}	8mA Max
Input Capacitance	24V Models 48V Models	22.0uF Max 10.0uF Max

Output		
Voltage Accuracy	Typical	±1.0%
Line Regulation	Full Input Range	±0.2%
Load Regulation	0%~100%	±0.2%
Temperature Drift	-40°C ~100°C	±0.03%/°C
Output Tolerance Band	All Conditions	±4%
Ripple & Noise (20MHz)	Peak-Peak (RMS)	3% (1%) V _O
Over Voltage Protection	V _{NOM} , 10% Load	115~130 %V _O
Output Current Limits	V _{NOM}	108%~125%
Voltage Trim	V _{NOM} , 10% Load	±10%
Input Ripple Rejection (<1KHz)	V _{NOM} , Full Load	-50dB
Step Load (2.5A/μS)	50%~75% Load	±6%Vo/500μS
Start-Up Delay Time	V _{NOM} , Full Load	20mS/250mS

TYPICAL WAVES AND CURVES

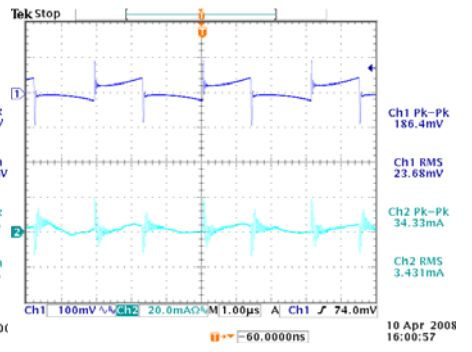
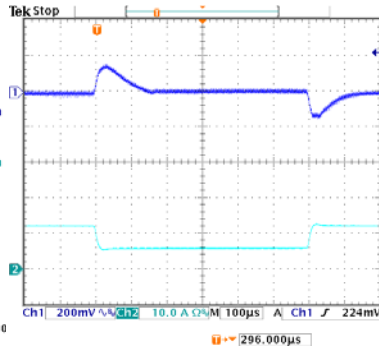
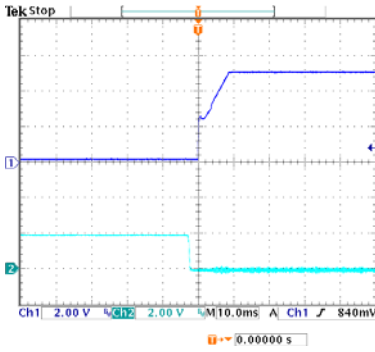

Start-up waveform of COE48050abcd-25XXX
(V_{IN} : 50V, Load: 25A)

Transient response of COE48050abcd-25XXX
(V_{IN} : 50V, Load: 12.5A/5.0A@2.5A/µs)

Input/Output ripples of COE48050abcd-25XXX
(V_{IN} : 50V, Load: 25A, L_{IN} =10uH)

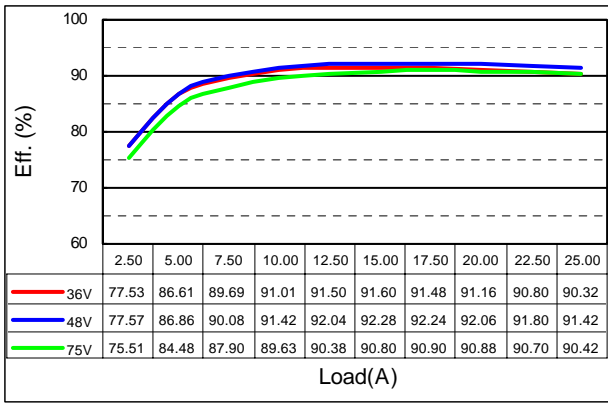

Efficiency plot of COE48050abcA-25XXX

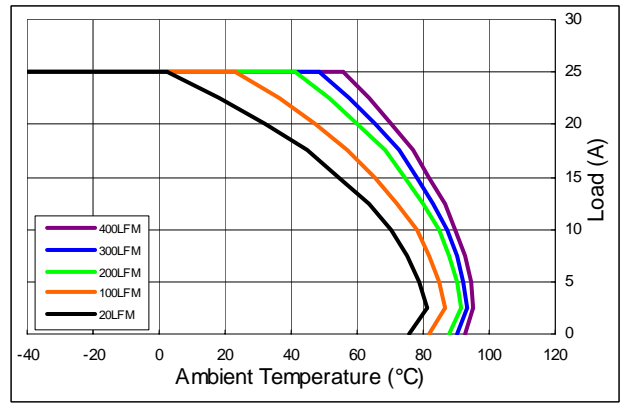

Derating curves of COE48050abcA-25XXX for $T_C=110^\circ C$

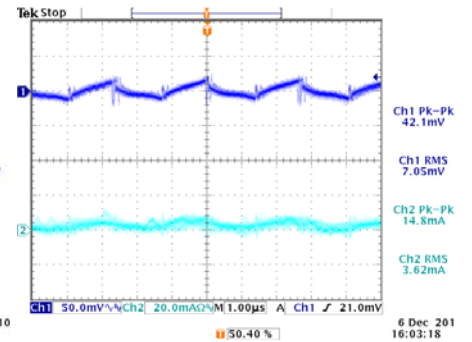
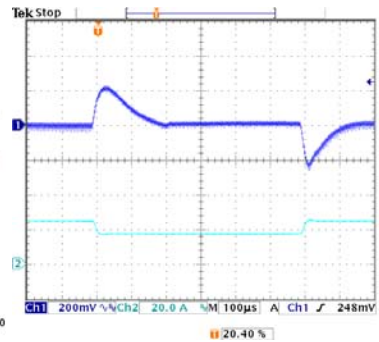
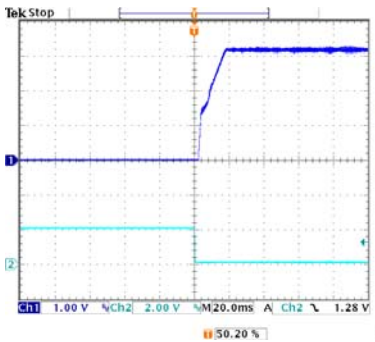

Start-up waveform of COE48033abcd-30XXX
(V_{IN} : 48V, Load: 30A)

Transient response of COE48033abcd-30XXX
(V_{IN} : 48V, Load: 25A/16A@2.5A/µs)

Input/Output ripples of COE48033abcd-30XXX
(V_{IN} : 48V, Load: 30A, L_{IN} =10uH)

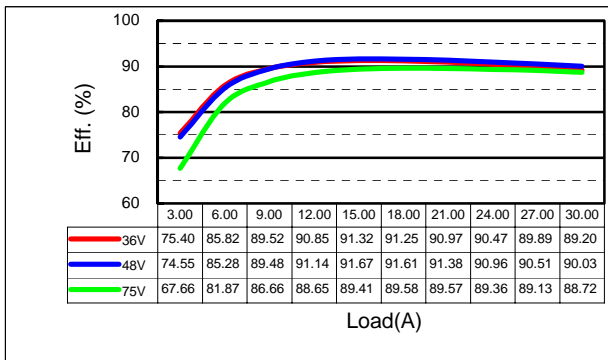

Efficiency plot of COE48033abcA-30XXX

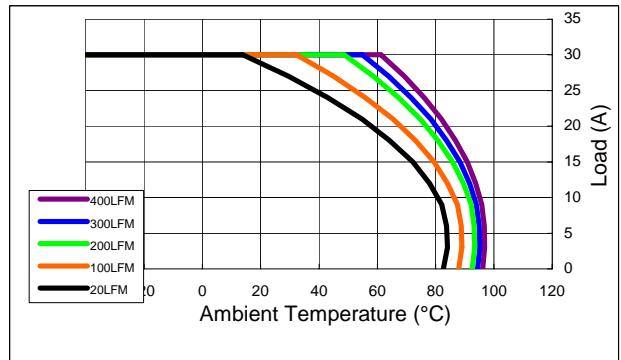

Derating curves of COE48033abcA-30XXX for $T_C=110^\circ C$

OPEN FRAME PACKAGE

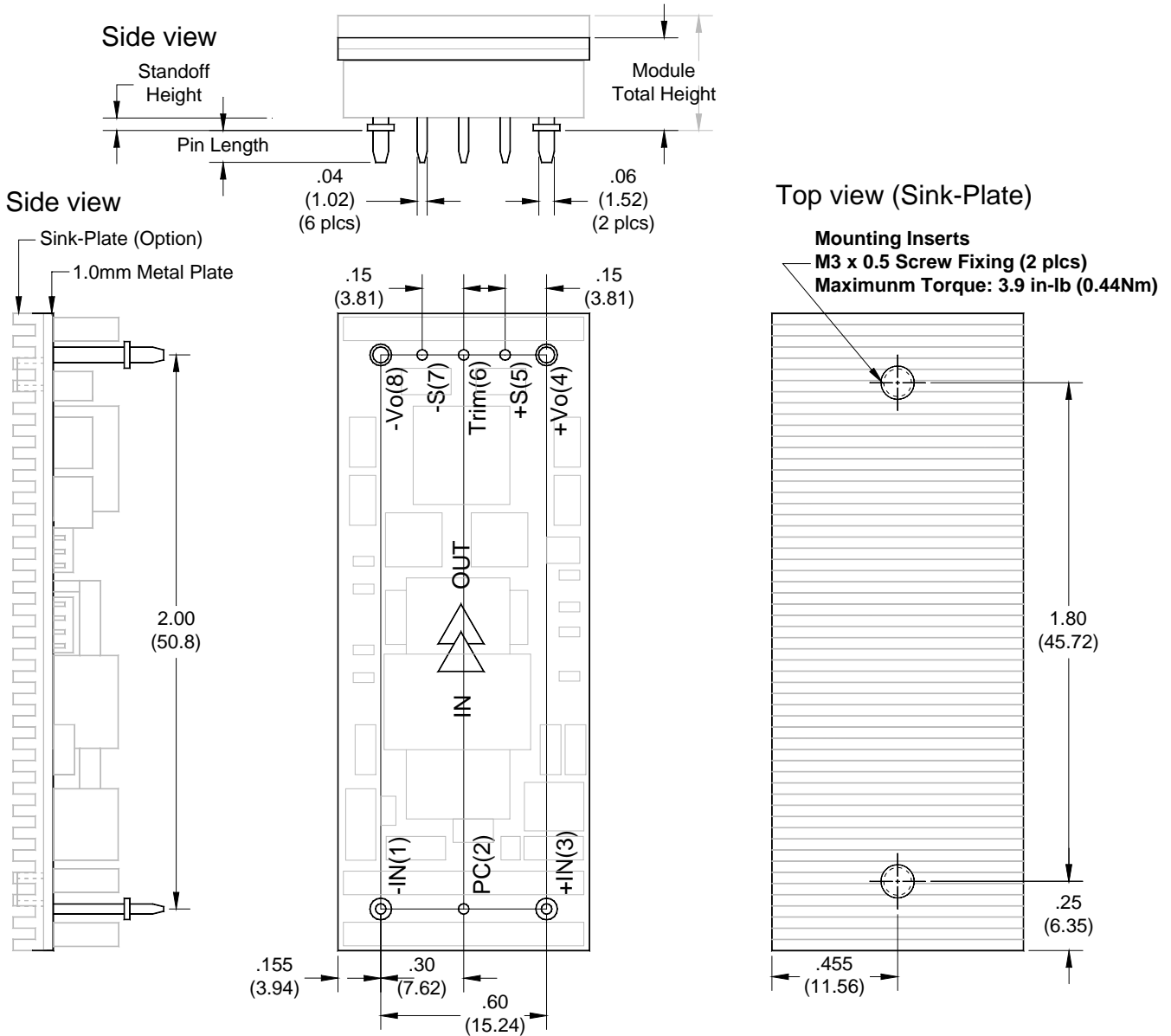

Dimensions and Pin Connections

Designation	Function Description	Pin #
-IN	Negative input	1
PC	Remote control. To turn-on and turn-off output.	2
+IN	Positive input	3
+Vo	Positive output	4
+S	Positive remote sense	5
TRIM	Output voltage adjust	6
-S	Negative remote sense	7
-Vo	Negative output	8

Dimensions: inches (mm)
Tolerances: .xx±0.02 (.x±0.5)
 .xxx±0.01 (.x±0.25)
Weight: 27g / 1.0mm metal plate
 32g / 3.0mm metal plate
Base plate: Aluminum alloy with anode oxide
Mounting inserts: Stainless steel
Maximum torque: 3.9 in-lb (0.44Nm)
Pin material: Copper alloy or Brass
Pin plating: Golden over Nickel

REFERENCED EMC CIRCUIT

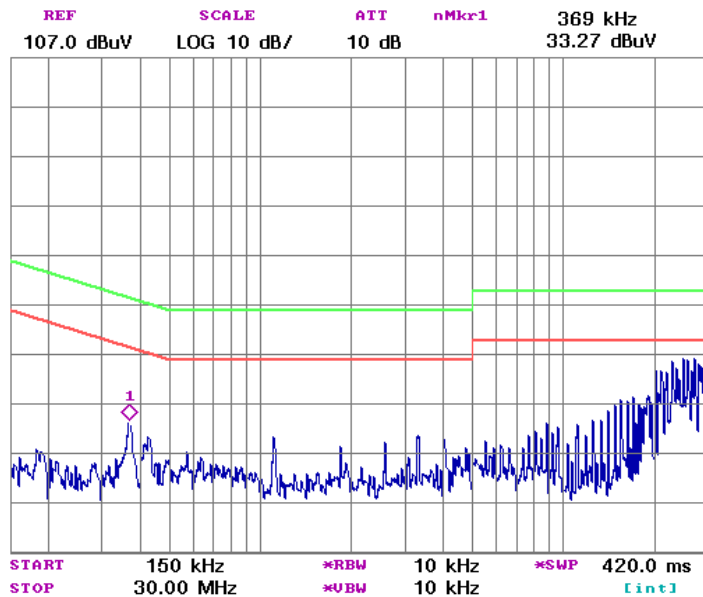

Referenced EMC Performance

The tested result shown in left-hand side is obtained by loading the power module with a resistive load only. It can be used as a design reference for customer system. However! The performance of customer's system depends on the whole system design. It should be noted that modifications on the circuit parameters and fine adjustment of the final layout affect the final EMC performance greatly.

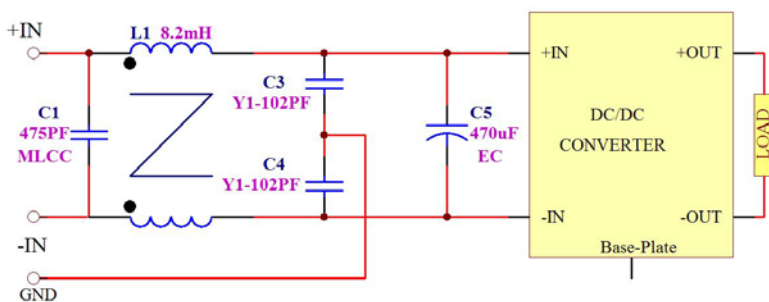

Measured conductive level of COE48050abcd-25XXX and referenced filter circuit

Bandwidth of EMC Components

No components are ideal for infinite frequency range. The bandwidth of EMC components should be taking into consideration when designing an EMC filter circuit. To connect ceramic capacitor with electricity capacitor in parallel and connect low inductance inductor with big one could get a better bandwidth.

NOTE:

1. It is recommended that the input should be protected by fuses or other protection devices.
2. All specifications are typical at nominal input, full load and 25°C unless otherwise noted.
3. Specifications are subject to change without notice.
4. Printed or downloaded datasheets are not subject to Glary document control.
5. Product labels shown, including safety agency certificates, may vary based on the date of manufacture.
6. Information provided in this documentation is for ordering purposes only.
7. This product is not designed for use in critical life support systems, equipment used in hazardous environments, nuclear control systems or other such applications, which necessitate specific safety and regulatory standards other than the ones listed in this datasheet.

IMPORTANT

- ✳ General specifications and the performances are related to standard series only, no special customer specification display here except requested items.
- ✳ In order to secure effective usage of converter and the validity of Glary's service and warranty coverage, please refer to the application notes for general usage. For needs of usage beyond the application notes, please contact to Glary headquarter or our regional sales representative office for help.

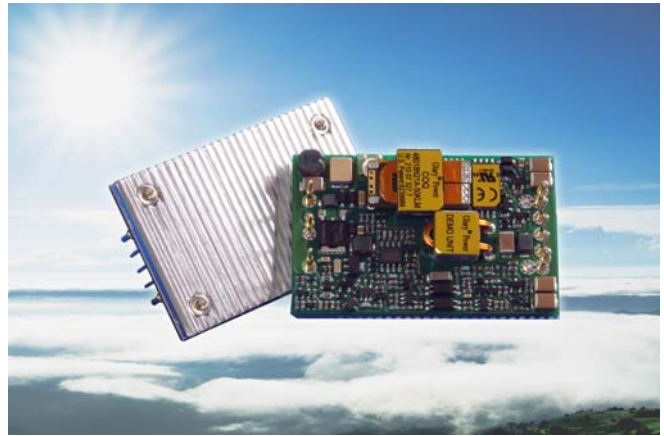

The **COQ** series provides up to 175W/50A outputs with industry standard quarter brick pin assignment. The efficient SR stage is combined with patented "Buck Reset" topology that would reduce power loss to achieve 145W/in³ power density. The multi-layer single side circuit board design plus the Sink-plate technology would enhance the thermal performance and improve its reliability. Modules are designed for Telecom, Servers, Networking equipments and other applications that use a 24V or 48V input bus.

PART NUMBER SYSTEM

COQ	48	120	a	b	c	d	-	14	XX	X
Series Name	Input Voltage	Output Voltage	Enable Logic	Pin Dimension	Standoff Height	Base-Plate		Output Current	Suffix	Version
COQ	48=36V~75V 24=18V~36V	Unit: 0.1V Increments 120=12V 050=5V	P: Positive N: Negative	0 : 0.12" 1 : 0.16" 2 : 0.20" 3 : 0.24"	0 : 0.02" 1 : 0.08" 2 : 0.16"	M : 1.0mm metal plate S : 3.0mm metal plate A : 3.0mm sink-plate B : 5.0mm sink-plate		00~50 : For output current rating	For marketing purpose only	

MODEL LIST (Contact to factory for special input / output)

Part Number *	Maximum Input	Maximum Output	Efficiency	Part Number *	Maximum Input	Maximum Output	Efficiency
COQ48120abcd-14XXX	36V~75V 184W	12.0V/14A 168W	91%	COQ24120abcd-12XXX	18V~36V 160W	12.0V/12A 144W	91%
COQ48070abcd-21XXX	36V~75V 163W	7.0V/21A 147W	90%	COQ24050abcd-30XXX	18V~36V 168W	5.0V/30A 150W	90%
COQ48050abcd-35XXX	36V~75V 195W	5.0V/35A 175W	90%	COQ24033abcd-35XXX	18V~36V 131W	3.3V/35A 116W	89%
COQ48033abcd-35XXX	36V~75V 131W	3.3V/35A 116W	89%	COQ24025abcd-40XXX	18V~36V 146W	2.5V/40A 100W	86%
COQ48025abcd-50XXX	36V~75V 146W	2.5V/50A 125W	86%	COQ24018abcd-50XXX	18V~36V 106W	1.8V/50A 90W	86%
COQ48018abcd-50XXX	36V~75V 106W	1.8V/50A 90W	86%	COQ24015abcd-50XXX	18V~36V 90W	1.5V/50A 75W	84%
COQ48015abcd-50XXX	36V~75V 90W	1.5V/50A 75W	84%				

REFERENCED THERMAL IMAGES

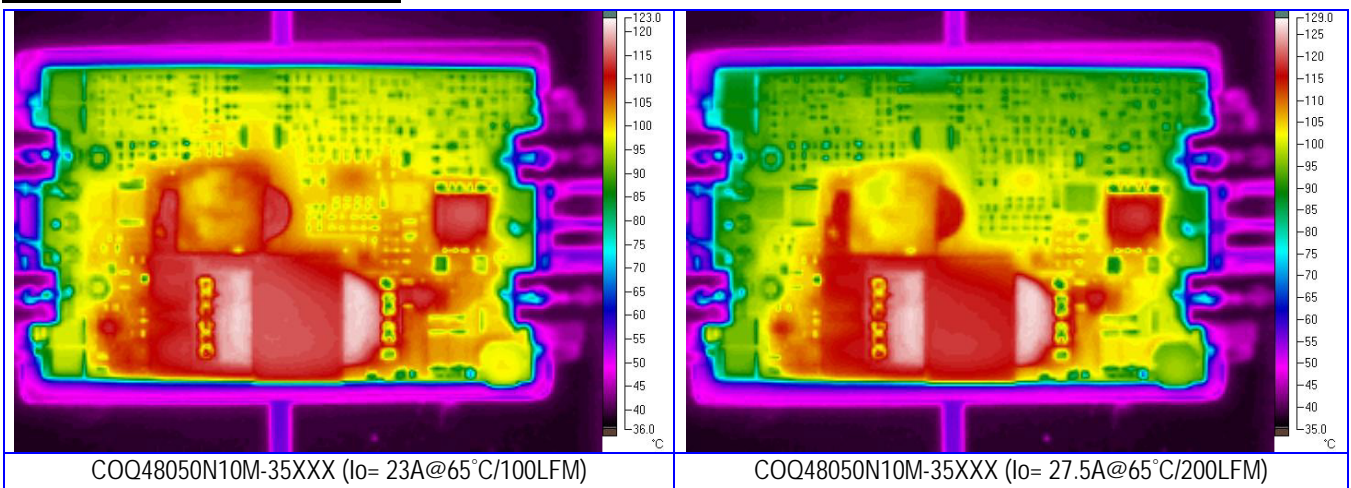

SPECIFICATIONS

Absolute Maximum Ratings		
Temperature	Operation Storage	-40°C to +110°C -55°C to +125°C
Input Voltage Range	Operation: 24V Models 48V Models Transient (100mS): 24V Models 48V Models	-0.5V to +40Vdc -0.5V to +80Vdc 50V Maximum 100V Maximum
Isolation Voltage	Input to Output Input to Case Output to Case	2.0KV Minimum 1.0KV Minimum 0.5KV Minimum
Remote Control		-0.5V to +12Vdc

General Parameters		
Conversion Efficiency	Typical	See table
Switching Frequency	Typical	330KHz
MTBF	Bellcore TR-332 issue 6	4.41×10 ⁶ hrs @GB/25°C. (COQ48033abcd-35XXX)
OTP	Internal	110°C(Tc) ±5°C
Weight	1.0mm metal plate 3.0mm metal plate	29g 43g

Control Functions		
Remote Control	Logic High Logic Low	+3.0V to +6.5V 0V to +1.0V
Input Current of Remote Control Pin		-0.5mA ~ +1.5mA

Input		
Operation Voltage Range	24V Models 48V Models	+18V to +36Vdc +36V to +75Vdc
Reflected Ripple Current	L _{EXT} = 10uH	30mA rms/100mAp-p
Power ON Voltage Ranges	24V Models 48V Models	+17.0V to +18.0Vdc +34.0V to +36.0Vdc
Power OFF Voltage Ranges	24V Models 48V Models	+15.6V to +16.6Vdc +31.2V to +33.2Vdc
Off State Input Current	V _{NOM}	6mA Max
Latch-State Input Current	V _{NOM}	8mA Max
Input Capacitance	24V Models 48V Models	22.0uF Max 10.0uF Max

Output		
Voltage Accuracy	Typical	±1.0%
Line Regulation	Full Input Range	±0.2%
Load Regulation	0%~100%	±0.2%
Temperature Drift	-40°C ~100°C	±0.03%/°C
Output Tolerance Band	All Conditions	±4%
Ripple & Noise (20MHz)	Peak-Peak (RMS)	3% (1%) V _O
Over Voltage Protection	V _{NOM} , 10% Load	115~130 %V _O
Output Current Limits	V _{NOM}	108%~125%
Voltage Trim	V _{NOM} , 10% Load	±10%
Input Ripple Rejection (<1KHz)	V _{NOM} , Full Load	-50dB
Step Load (2.5A/μS)	50%~75% Load	±6%Vo/500μS
Start-Up Delay Time	V _{NOM} , Full Load	20mS/250mS

TYPICAL WAVES AND CURVES

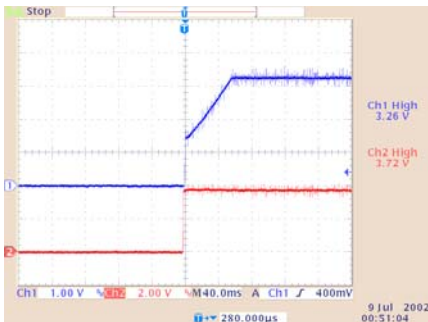

Start-up waveform of COQ48033abcd-35XXX
(V_{IN} : 50V, Load: 35A)

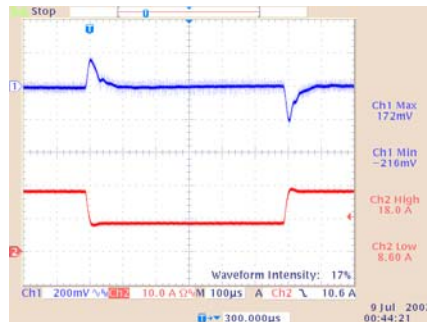

Transient response of COQ48033abcd-35XXX
(V_{IN} : 48V, Load: 18A/9A@2.5A/ μ S)

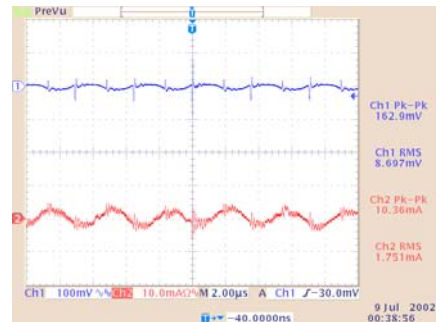

Input/Output ripples of COQ48033abcd-35XXX
(V_{IN} : 50V, Load: 35A, L_{IN} =10 μ H)

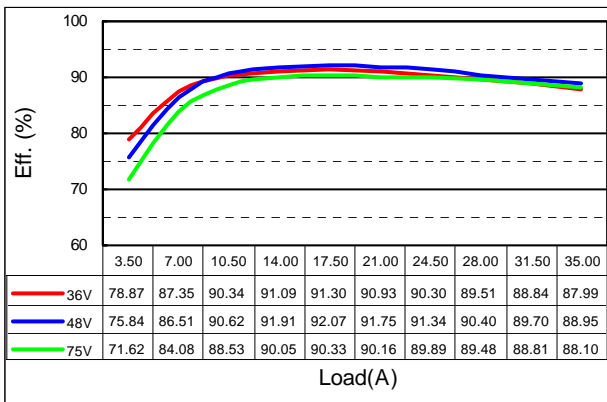

Efficiency plot of COQ48033abcA-35XXX

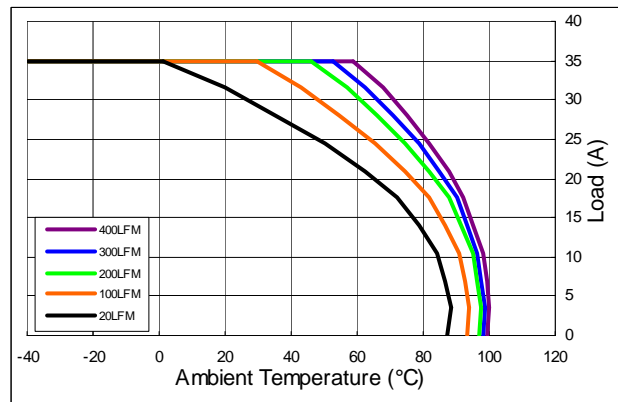

Derating curves of COQ48033abcA-35XXX for $T_C = 110^\circ\text{C}$

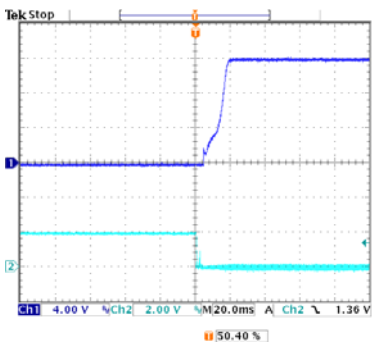

Start-up waveform of COQ48120abcd-14XXX
(V_{IN} : 48V, Load: 14A)

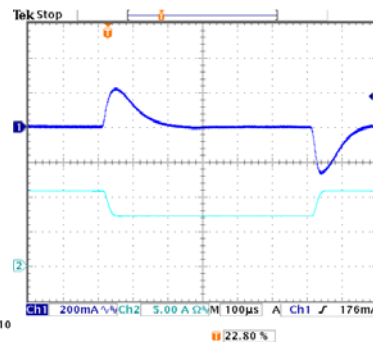

Transient response of COQ48120abcd-14XXX
(V_{IN} : 48V, Load: 10.5A/7.5A@2.5A/ μ S)

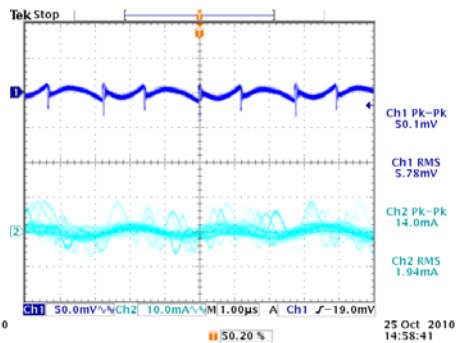

Input/Output ripples of COQ48120abcd-14XXX
(V_{IN} : 48V, Load: 14A, L_{IN} =10 μ H)

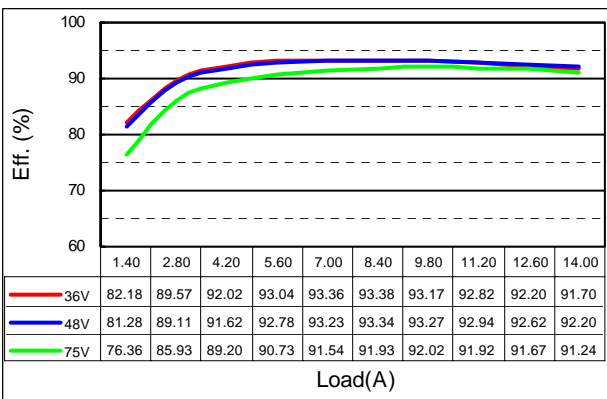

Efficiency plot of COQ48120abcA-14XXX

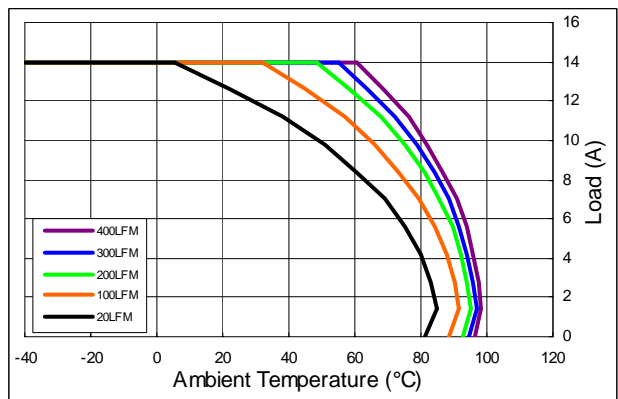

Derating curves of COQ48120abcA-14XXX for $T_C = 110^\circ\text{C}$

OPEN FRAME PACKAGE

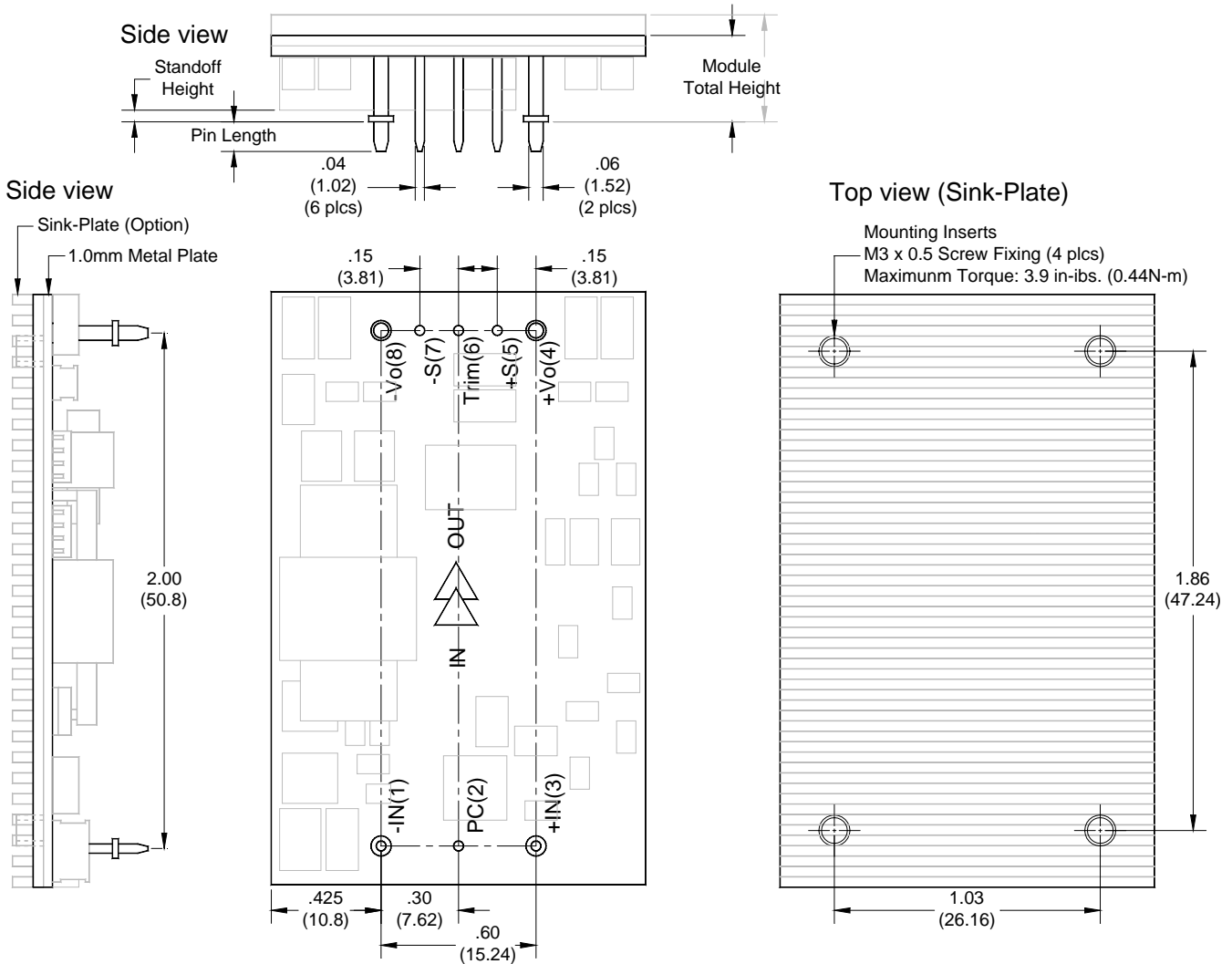

Dimensions and Pin Connections

Designation	Function Description	Pin #
-IN	Negative input	1
PC	Remote control. To turn-on and turn-off output.	2
+IN	Positive input	3
+Vo	Positive output	4
+S	Positive remote sense	5
TRIM	Output voltage adjust	6
-S	Negative remote sense	7
-Vo	Negative output	8

Dimensions: inches (mm)

Tolerances: .xx±0.02 (.x±0.5)

.xxx±0.01 (.x±0.25)

Weight: 29g / 1.0mm metal plate
43g / 3.0mm metal plate

Base plate: Aluminum alloy with anode oxide

Mounting inserts: Stainless steel

Maximum torque: 3.9 in-lb (0.44Nm)

Pin material: Copper alloy or Brass

Pin plating: Golden over Nickel

REFERENCED EMC CIRCUIT

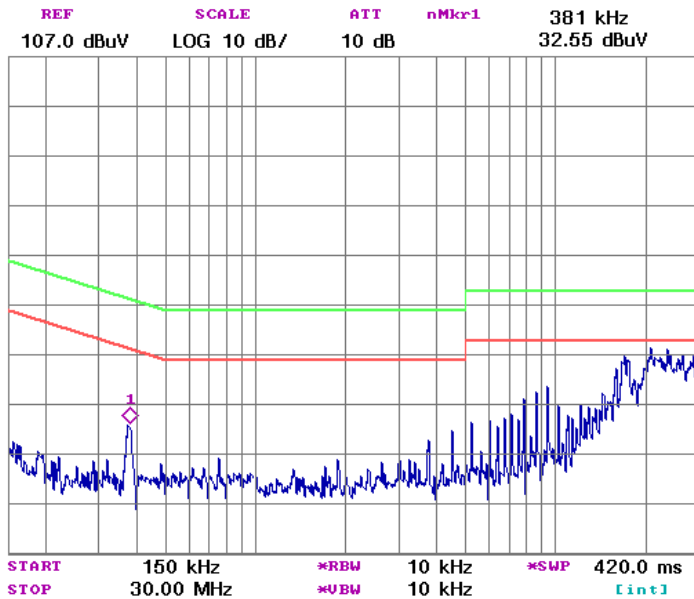

Referenced EMC Performance

The tested result shown in left-hand side is obtained by loading the power module with a resistive load only. It can be used as a design reference for customer system. However! The performance of customer's system depends on the whole system design. It should be noted that modifications on the circuit parameters and fine adjustment of the final layout affect the final EMC performance greatly.

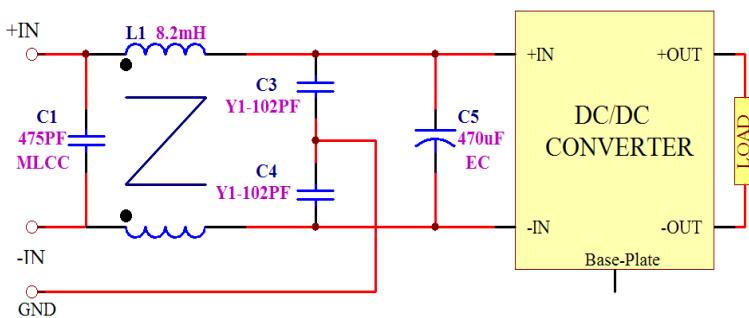

Measured conductive level of COQ48050abcd-25XXX and referenced filter circuit

Bandwidth of EMC Components

No components are ideal for infinite frequency range. The bandwidth of EMC components should be taking into consideration when designing an EMC filter circuit. To connect ceramic capacitor with electricity capacitor in parallel and connect low inductance inductor with big one could get a better bandwidth.

NOTE:

1. It is recommended that the input should be protected by fuses or other protection devices.
2. All specifications are typical at nominal input, full load and 25°C unless otherwise noted.
3. Specifications are subject to change without notice.
4. Printed or downloaded datasheets are not subject to Glary document control.
5. Product labels shown, including safety agency certificates, may vary based on the date of manufacture.
6. Information provided in this documentation is for ordering purposes only.
7. This product is not designed for use in critical life support systems, equipment used in hazardous environments, nuclear control systems or other such applications, which necessitate specific safety and regulatory standards other than the ones listed in this datasheet.

IMPORTANT

- ✘ General specifications and the performances are related to standard series only, no special customer specification display here except requested items.
- ✘ In order to secure effective usage of converter and the validity of Glary's service and warranty coverage, please refer to the application notes for general usage. For needs of usage beyond the application notes, please contact to Glary headquarter or our regional sales representative office for help.

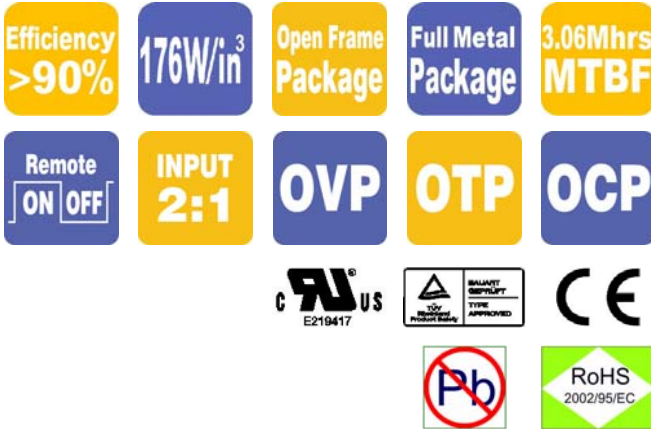

The **CPH** series provides up to 350W/100A outputs with industry standard half brick package. The efficient SR stage is combined with patented "Buck Reset" topology that would reduce power loss to achieve 176W/in³ power density. The single side component and multi-layer circuit board design plus the patented Sink-Plate technology would enhance the thermal performance and improve its reliability. Modules are designed for Telecom, Servers, Networking equipments and other applications that use a 24V or 48V input bus.

PART NUMBER SYSTEM

CPH	48	050	a	b	c	d	-	70	XX	X
Series Name	Input Voltage	Output Voltage	Enable Logic	Pin Dimension	Standoff Height	Base-Plate		Output Current	Suffix	Version
CPH	48=36V~75V 24=18V~36V	Unit: 0.1V Increments 050=5V 033=3.3V	P: Positive N: Negative	0 : 0.12" 1 : 0.16" 2 : 0.20" 3 : 0.24"	0 : 0.02" 1 : 0.08" 2 : 0.16"	M : 1.0mm Metal Plate A : 3.0mm Sink-Plate B : 5.0mm Sink-Plate E : Metallic enclosure (1.0mm metal plate)		00~A0 : For output current rating		For marketing purpose only

MODEL LIST (Contact to factory for special input / output)

Part Number *	Maximum Input		Maximum Output		Efficiency	Part Number *	Maximum Input		Maximum Output		Efficiency
CPH48050abcd-70XXX	36V~75V	390W	5.0V/70A	350W	90%	CPH24050abcd-70XXX	18V~36V	395W	5.0V/70A	350W	89%
CPH48033abcd-70XXX	36V~75V	260W	3.3V/70A	231W	89%	CPH24033abcd-70XXX	18V~36V	265W	3.3V/70A	231W	88%
CPH48025abcd-80XXX	36V~75V	230W	2.5V/80A	200W	88%	CPH24025abcd-80XXX	18V~36V	235W	2.5V/80A	200W	87%
CPH48018abcd-A0XXX	36V~75V	215W	1.8V/100A	180W	85%	CPH24018abcd-A0XXX	18V~36V	220W	1.8V/100A	180W	84%
CPH48015abcd-A0XXX	36V~75V	185W	1.5V/100A	150W	84%	CPH24015abcd-A0XXX	18V~36V	190W	1.5V/100A	150W	83%

REFERENCED THERMAL IMAGES

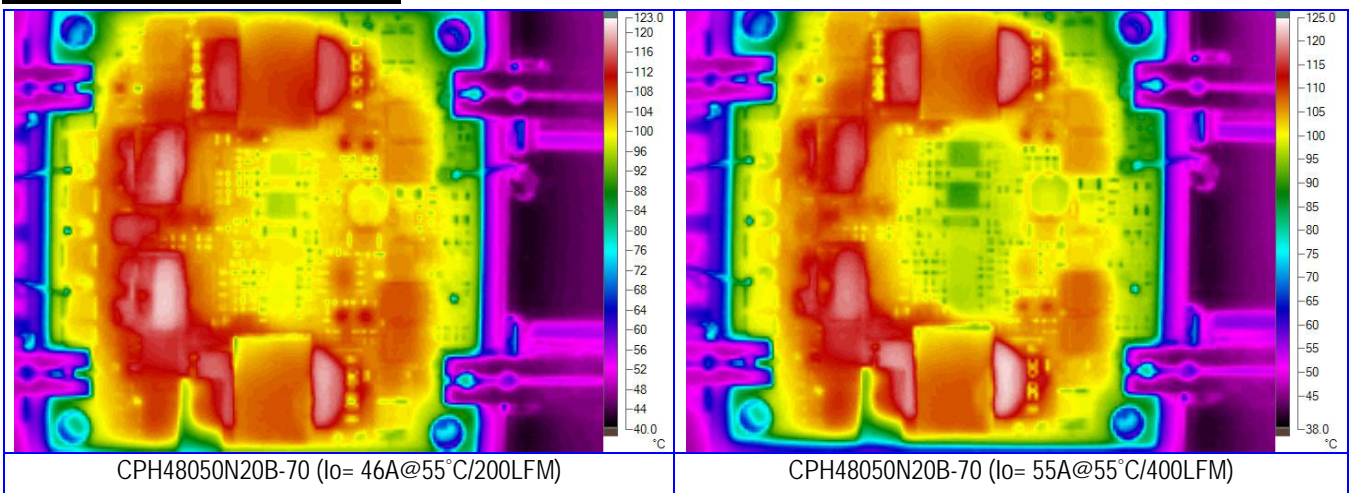

SPECIFICATIONS

Absolute Maximum Ratings		
Temperature	Operation Storage	-40°C to +110°C -55°C to +125°C
Input Voltage Range	Operation: 24V Models 48V Models Transient (100mS): 24V Models 48V Models	-0.5V to +40Vdc -0.5V to +80Vdc 50V Maximum 100V Maximum
Isolation Voltage	Input to Output Input to Case Output to Case	2.0KV Minimum 1.0KV Minimum 1.0KV Minimum
Remote Control		-0.5V to +12Vdc

General Parameters		
Conversion Efficiency	Typical	See table
Switching Frequency	Typical	330KHz
MTBF	Bellcore TR-332 issue 6	3.06x10 ⁶ hrs @GB/25°C (CPH48050abcd-70XXX)
OTP	Internal	110°C(Tc) ±5°C
Weight	Open frame Metallic enclosure	60g / 1.0mm metal plate 95g / 1.0mm metal plate

Control Functions		
Remote Control	Logic High Logic Low	+3.0V to +6.5V 0V to +1.0V
Input Current of Remote Control Pin		-0.5mA ~ +1.5mA

Input		
Operation Voltage Range	24V Models 48V Models	+18V to +36Vdc +36V to +75Vdc
Reflected Ripple Current	L _{EXT} = 10uH	30mA rms/100mAp-p
Power ON Voltage Ranges	24V Models 48V Models	+17.0V to +18.0Vdc +34.0V to +36.0Vdc
Power OFF Voltage Ranges	24V Models 48V Models	+15.6V to +16.6Vdc +31.2V to +33.2Vdc
Off State Input Current	V _{NOM}	6mA Max
Latch-State Input Current	V _{NOM}	8mA Max
Input Capacitance	24V Models 48V Models	42.0uF Max 15.0uF Max

Output		
Voltage Accuracy	Typical	±1.0%
Line Regulation	Full Input Range	±0.3%
Load Regulation	0%~100%	±0.3%
Temperature Drift	-40°C ~100°C	±0.03%/°C
Output Tolerance Band	All Conditions	±4%
Ripple & Noise (20MHz)	Peak-Peak (RMS)	3% (1%) V _O
Over Voltage Protection	V _{NOM} , 10% Load	115~130 %V _O
Output Current Limits	V _{NOM}	108%~125%
Voltage Trim	V _{NOM} , 10% Load	±10%
Input Ripple Rejection (<1KHz)	V _{NOM} , Full Load	-50dB
Step Load (2.5A/μS)	50%~75% Load	±6%Vo/500μS
Start-Up Delay Time	V _{NOM} , Full Load	20mS/250mS

TYPICAL WAVES AND CURVES

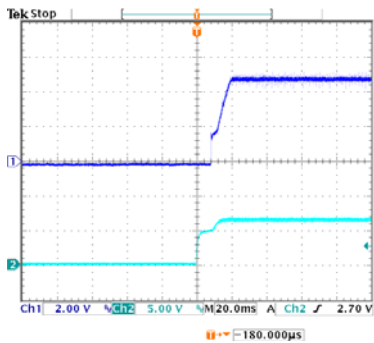

Start-up waveform of CPH48050abcd-70XXX
(V_{IN} : 48V, Load: 70A)

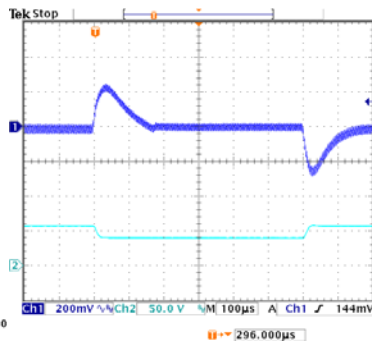

Transient response of CPH48050abcd-70XXX
(V_{IN} : 48V, Load: 52.5A/35.0A@2.5A/µs)

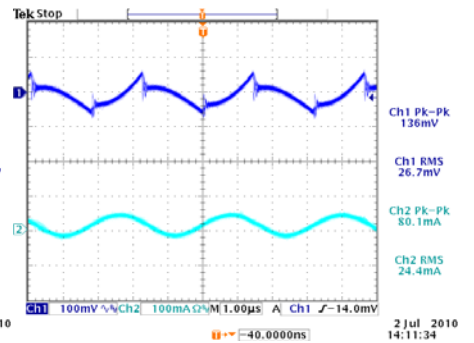

Input/Output ripples of CPH48050abcd-70XXX
(V_{IN} : 48V, Load: 70A, L_{IN} =10µH)

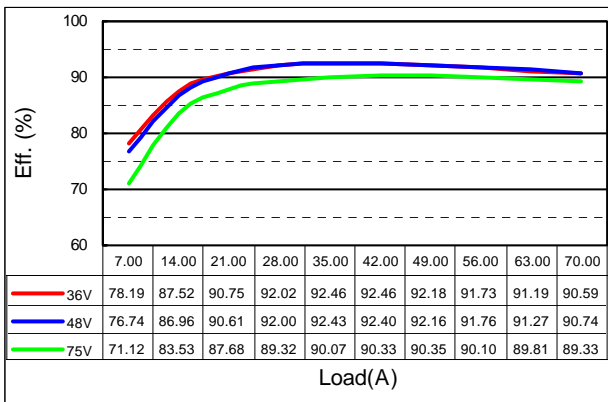

Efficiency Plot of CPH48050abcB-70XXX

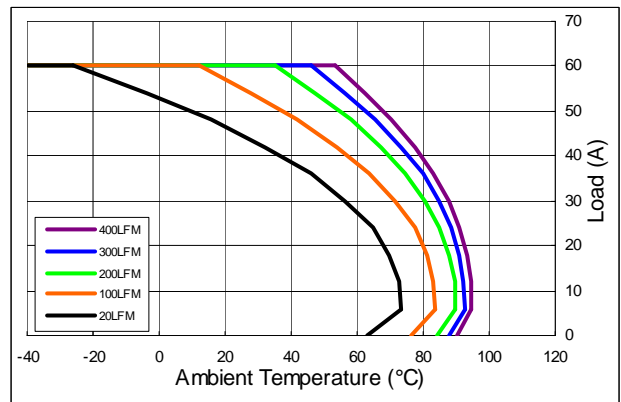

Derating Curves of CPH48050abcB-70XXX for $T_C = 110^\circ\text{C}$

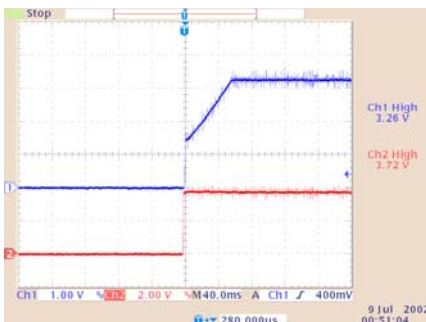

Start-up waveform of CPH48033abcd-70XXX
(V_{IN} : 48V, Load: 70A)

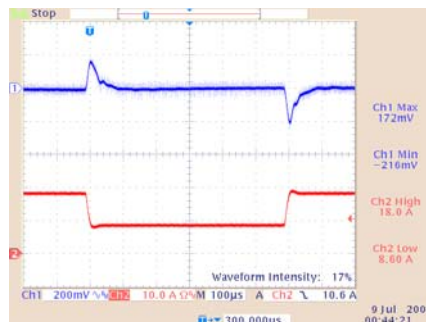

Transient response of CPH48033abcd-70XXX
(V_{IN} : 48V, Load: 18A/8A@2.5A/µs)

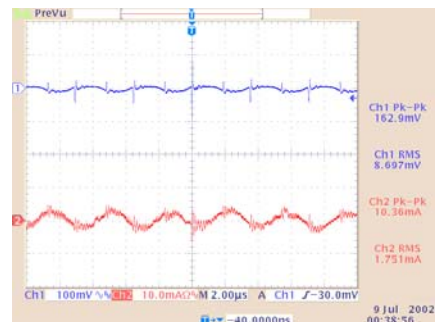

Input/Output ripples of CPH48033abcd-70XXX
(V_{IN} : 48V, Load: 70A, L_{IN} =10µH)

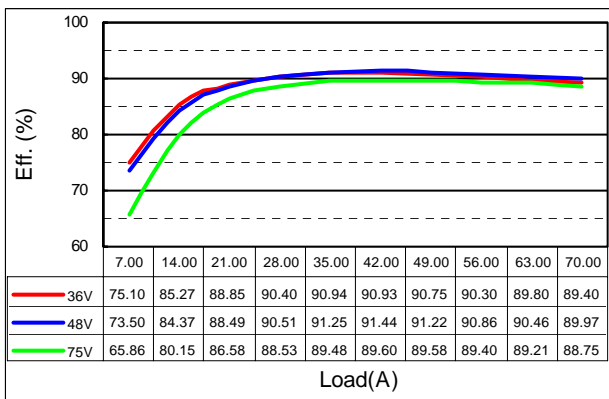

Efficiency Plot of CPH48033abcB-70XXX

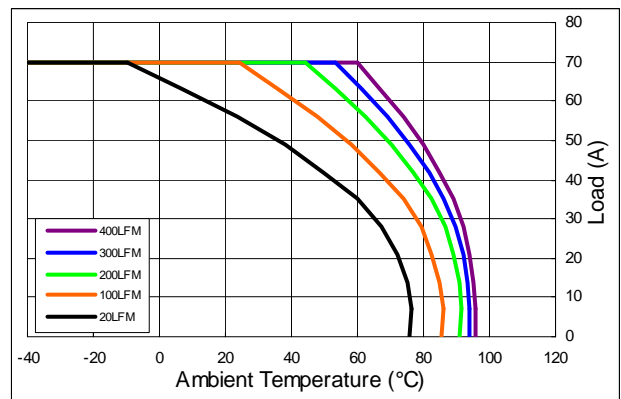

Derating Curves of CPH48033abcB-70XXX for $T_C = 110^\circ\text{C}$

METAL ENCLOSED PACKAGE

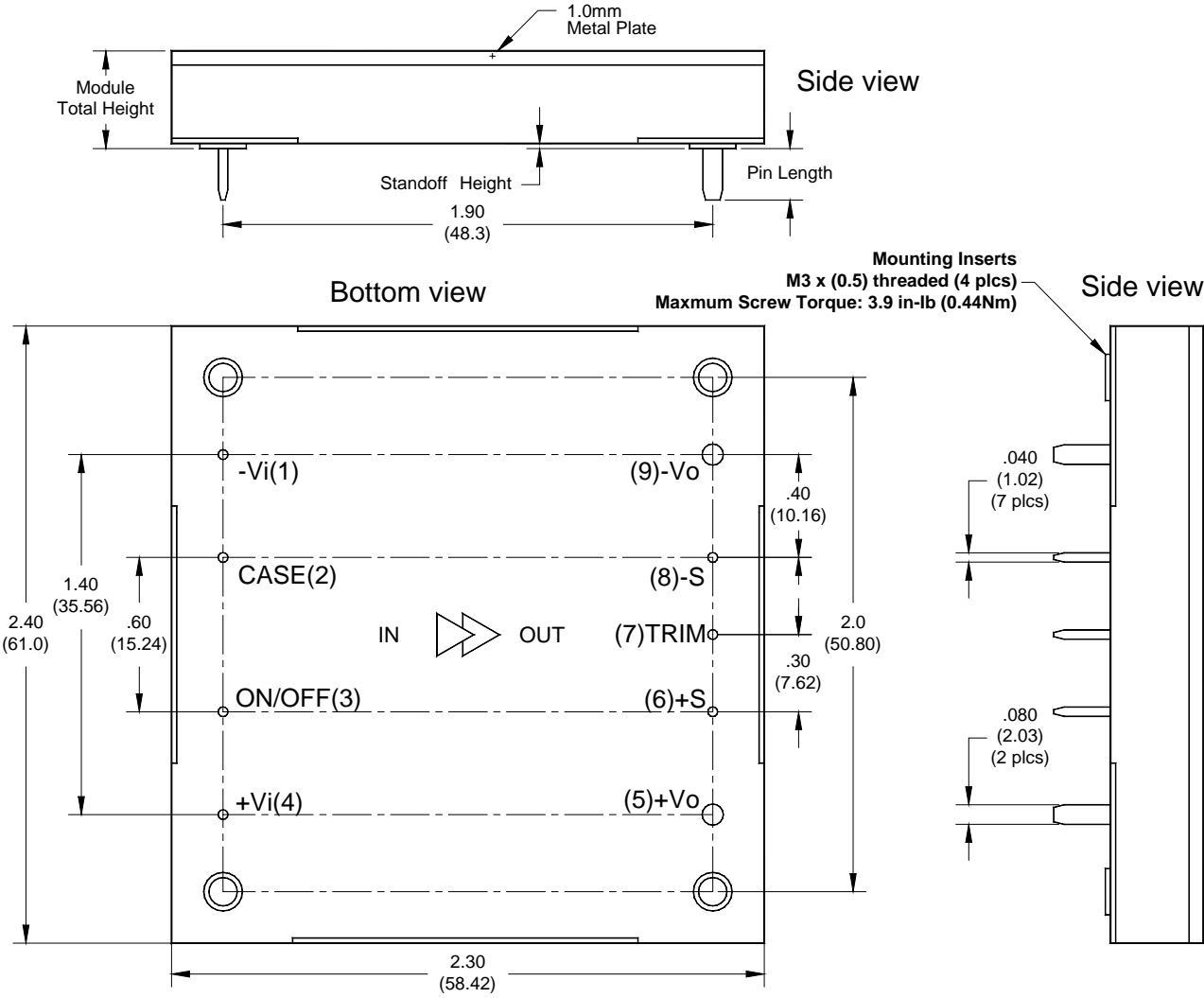

Dimensions and Pin Connections

Designation	Function Description	Pin #
-Vi	Negative input	1
CASE	Connected to base plate	2
ON/OFF	Remote control. To turn-on and turn-off output.	3
+Vi	Positive input	4
+Vo	Positive output	5
+S	Positive remote sense	6
TRIM	Output voltage adjust	7
-S	Negative remote sense	8
-Vo	Negative output	9

Dimensions: inches (mm)
Tolerances: .xx±0.02 (.x±0.5)
 .xxx±0.01 (.x±0.25)
Weight: 95g / 1.0mm metal plate
Base plate: Aluminum alloy with anode oxide
Mounting inserts: Stainless steel
Maximum torque: 3.9 in-lb (0.44Nm)
Pin material: Copper alloy or Brass
Pin plating: Golden over Nickel

OPEN FRAME PACKAGE

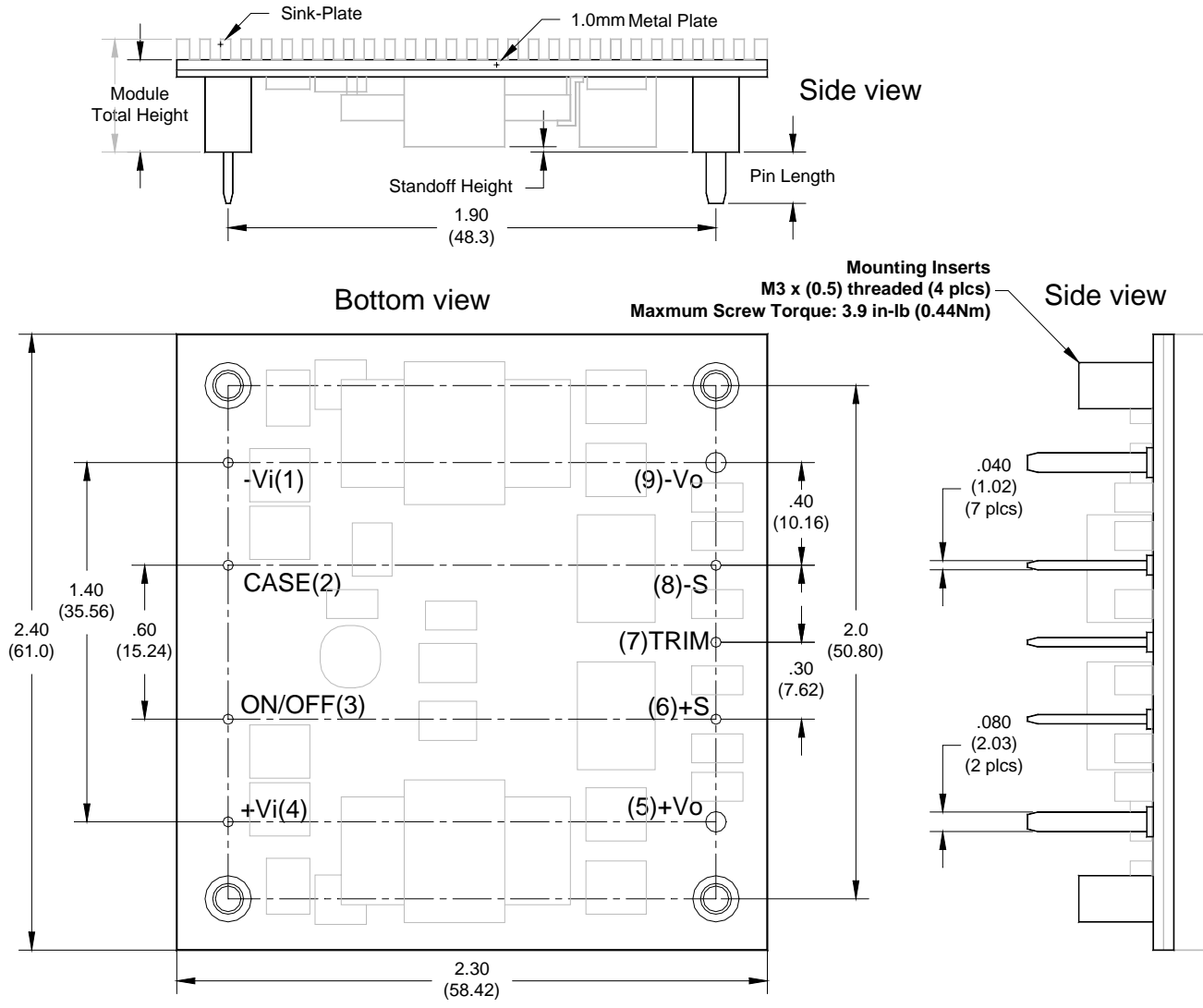

Dimensions and Pin Connections

Designation	Function Description	Pin #
-Vi	Negative input	1
CASE	Connected to base plate	2
ON/OFF	Remote control. To turn-on and turn-off output.	3
+Vi	Positive input	4
+Vo	Positive output	5
+S	Positive remote sense	6
TRIM	Output voltage adjust	7
-S	Negative remote sense	8
-Vo	Negative output	9

Dimensions: inches (mm)
Tolerances: .xx±0.02 (.x±0.5)
 .xxx±0.01 (.x±0.25)
Weight: 60g / 1.0mm metal plate
Base plate: Aluminum alloy with anode oxide
Mounting inserts: Stainless steel
Maximum torque: 3.9 in-lb (0.44Nm)
Pin material: Copper alloy or Brass
Pin plating: Golden over Nickel

REFERENCED EMC CIRCUIT

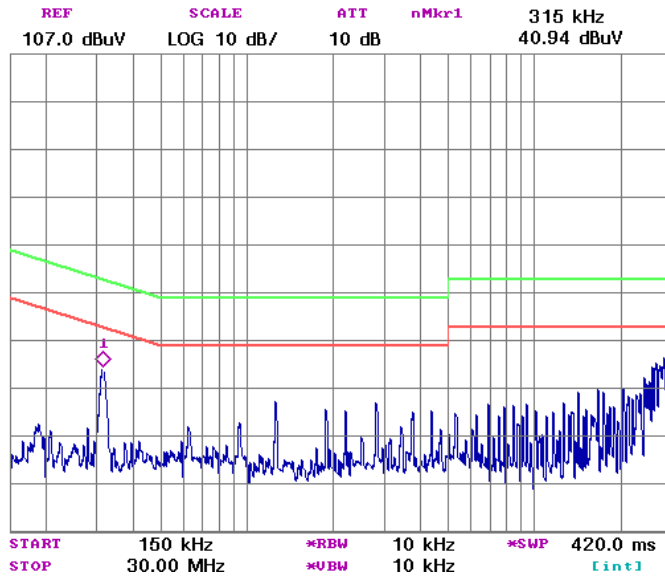

Referenced EMC Performance

The tested result shown in left-hand side is obtained by loading the power module with a resistive load only. It can be used as a design reference for customer system. However! The performance of customer's system depends on the whole system design. It should be noted that modifications on the circuit parameters and fine adjustment of the final layout affect the final EMC performance greatly.

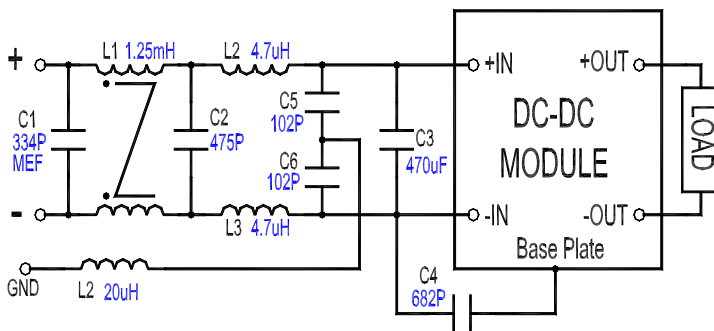

Measured conductive level of CPH48050abcd-70XXX and referenced filter circuit

Bandwidth of EMC Components

No components are ideal for infinite frequency range. The bandwidth of EMC components should be taking into consideration when designing an EMC filter circuit. To connect ceramic capacitor with electricity capacitor in parallel and connect low inductance inductor with big one could get a better bandwidth.

NOTE:

1. It is recommended that the input should be protected by fuses or other protection devices.
2. All specifications are typical at nominal input, full load and 25°C unless otherwise noted.
3. Specifications are subject to change without notice.
4. Printed or downloaded datasheets are not subject to Glary document control.
5. Product labels shown, including safety agency certificates, may vary based on the date of manufacture.
6. Information provided in this documentation is for ordering purposes only.
7. This product is not designed for use in critical life support systems, equipment used in hazardous environments, nuclear control systems or other such applications, which necessitate specific safety and regulatory standards other than the ones listed in this datasheet.

IMPORTANT

- * General specifications and the performances are related to standard series only, no special customer specification display here except requested items.
- * In order to secure effective usage of converter and the validity of Glary's service and warranty coverage, please refer to the application notes for general usage. For needs of usage beyond the application notes, please contact to Glary headquarter or our regional sales representative office for help.



The **NH** series provides up to 336W/21A outputs with industry standard half brick package. The efficient Non-SR technology is combined with ultra low leakage inductance magnetic design to gives converters "SR-like" conversion efficiency. The multi-layer single side circuit board design plus the Sink-plate technology would enhance the thermal performance and improve its reliability. Modules are designed for Telecom, Servers, Networking equipments and other applications that use a 24V or 48V input bus.

PART NUMBER SYSTEM

NH	48	480	a	b	c	d	-	07	XX	X
Series Name	Input Voltage	Output Voltage	Enable Logic	Pin Dimension	Standoff Height	Base-Plate		Output Current	Suffix	Version
NH	48=36V~75V 24=18V~36V	Unit: 0.1V Increments 480=48V 120=12V	P: Positive N: Negative	0 : 0.12" 1 : 0.16" 2 : 0.20" 3 : 0.24"	0 : 0.02" 1 : 0.08" 2 : 0.16"	M : 1.0mm Metal Plate A : 3.0mm Sink-Plate B : 5.0mm Sink-Plate E : Metallic enclosure (1.0mm metal plate)		00~21 : For output current rating	For marketing purpose only	

MODEL LIST (Contact to factory for special input / output)

Part Number *	Maximum Input	Maximum Output	Efficiency	Part Number *	Maximum Input	Maximum Output	Efficiency
NH48480abcd-07XXX	36V~75V 378W	48V/7.0A 336W	89%	NH24480abcd-07XXX	18V~36V 381W	48V/7.0A 336W	88%
NH48280abcd-11XXX	36V~75V 342W	28V/11A 308W	90%	NH24280abcd-11XXX	18V~36V 342W	28V/11A 308W	90%
NH48240abcd-12XXX	36V~75V 323W	24V/12A 288W	89%	NH24240abcd-12XXX	18V~36V 323W	24V/12A 288W	89%
NH48240abcd-07XXX	36V~75V 174W	24V/6.5A 156W	90%	NH24120abcd-21XXX	18V~36V 280W	12V/21A 252W	90%
NH48120abcd-21XXX	36V~75V 280W	12V/21A 252W	90%				

REFERENCED THERMAL IMAGES

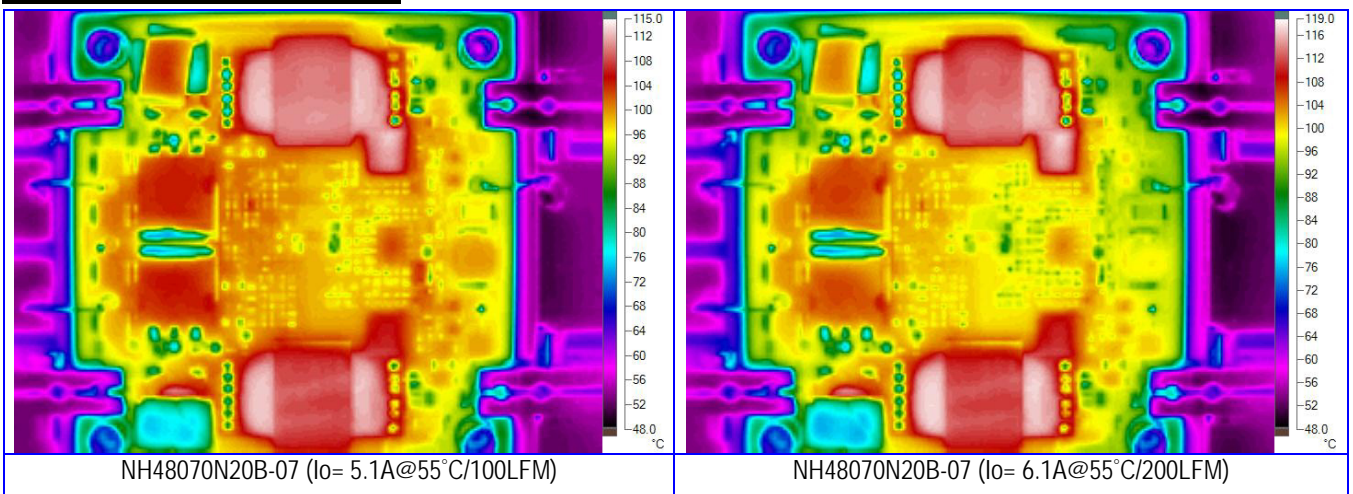

SPECIFICATIONS

Absolute Maximum Ratings		
Temperature	Operation Storage	-40°C to +110°C -55°C to +125°C
Input Voltage Range	Operation: 24V Models 48V Models Transient (100mS): 24V Models 48V Models	-0.5V to +40Vdc -0.5V to +80Vdc 50V Maximum 100V Maximum
Isolation Voltage	Input to Output Input to Case Output to Case	2.0KV Minimum 1.0KV Minimum 1.0KV Minimum
Remote Control		-0.5V to +12Vdc

General Parameters		
Conversion Efficiency	Typical	See table
Switching Frequency	Typical	340KHz
MTBF	Bellcore TR-332 issue 6	4.11×10 ⁶ hrs @GB/25°C. (NH24280abcd-11XXX)
OTP	Internal	110°C(Tc) ±5°C
Weight	Open frame Metallic enclosure	60g / 1.0mm metal plate 95g / 1.0mm metal plate

Control Functions		
Remote Control	Logic High Logic Low	+3.0V to +6.5V 0V to +1.0V
Input Current of Remote Control Pin		-0.5mA ~ +1.5mA

Input		
Operation Voltage Range	24V Models 48V Models	+18V to +36Vdc +36V to +75Vdc
Reflected Ripple Current	L _{EXT} = 10uH	30mA rms/100mAp-p
Power ON Voltage Ranges	24V Models 48V Models	+17.0V to +18.0Vdc +34.0V to +36.0Vdc
Power OFF Voltage Ranges	24V Models 48V Models	+15.6V to +16.6Vdc +31.2V to +33.2Vdc
Off State Input Current	V _{NOM}	6mA Max
Latch-State Input Current	V _{NOM}	8mA Max
Input Capacitance	24V Models 48V Models	42.0uF Max 15.0uF Max

Output		
Voltage Accuracy	Typical	±1.0%
Line Regulation	Full Input Range	±0.3%
Load Regulation	2%~100%	±0.3%
Temperature Drift	-40°C ~100°C	±0.03%/°C
Output Tolerance Band	All Conditions	±4%
Ripple & Noise (20MHz)	Peak-Peak (RMS)	3% (1%) V _O
Over Voltage Protection	V _{NOM} , 10% Load	115~130 %V _O
Output Current Limits	V _{NOM}	108%~125%
Voltage Trim	V _{NOM} , 10% Load	±10%
Input Ripple Rejection (<1KHz)	V _{NOM} , Full Load	-50dB
Step Load (2.5A/μS)	50%~75% Load	±6%Vo/500μS
Start-Up Delay Time	V _{NOM} , Full Load	20mS/250mS

TYPICAL WAVES AND CURVES

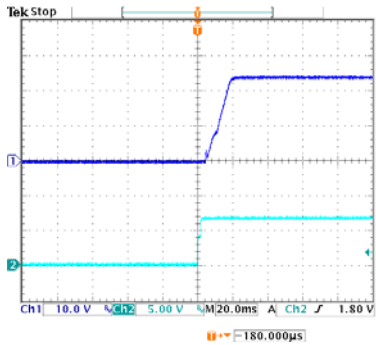

Start-up waveform of NH48240abcd-07XXX
(V_{IN} : 48V, Load: 6.5A)

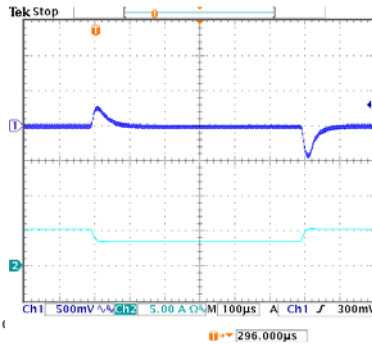

Transient response of NH48240abcd-07XXX
(V_{IN} : 48V, Load: 5.0A/3.3A@2.5A/µs)

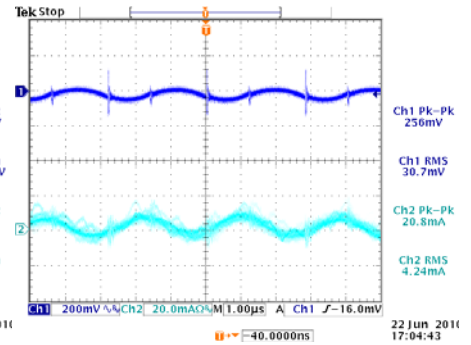

Input/Output ripples of NH48240abcd-07XXX
(V_{IN} : 48V, Load: 6.5A, L_{IN} =10uH)

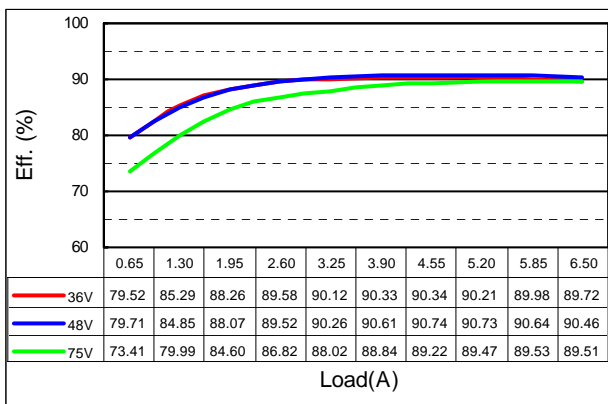

Efficiency plot of NH48240abcB-07XXX

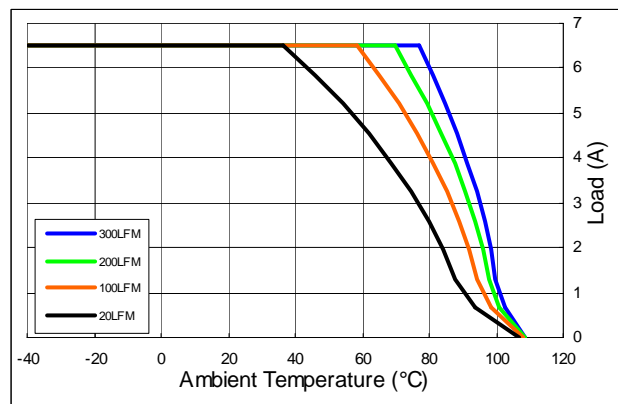

Derating curves of NH48240abcB-07XXX for $T_C = 110^\circ\text{C}$

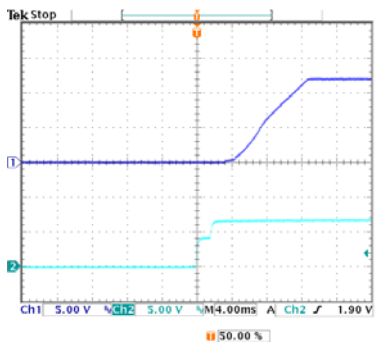

Start-up waveform of NH48120abcd-21XXX
(V_{IN} : 48V, Load: 21A)

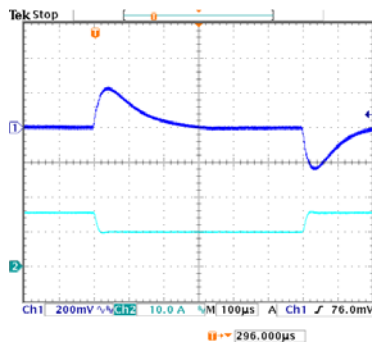

Transient response of NH48120abcd-21XXX
(V_{IN} : 48V, Load: 15.5A/9.5A@2.5A/µs)

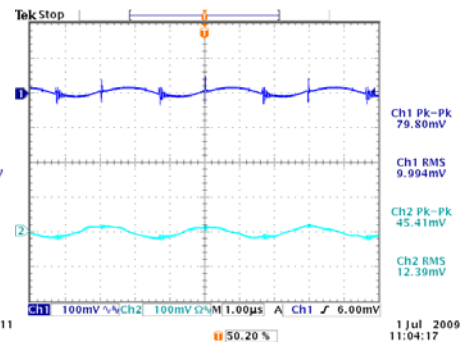

Input/Output ripples of NH48120abcd-21XXX
(V_{IN} : 48V, Load: 21A, L_{IN} =10uH)

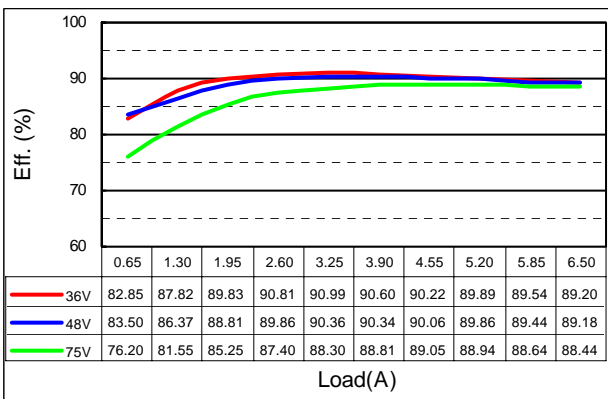

Efficiency plot of NH48120abcB-21XXX

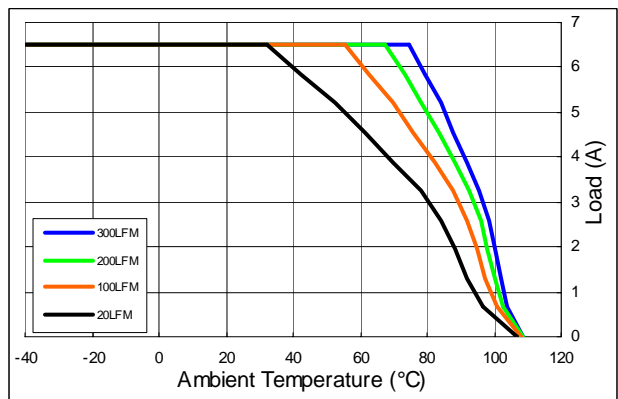

Derating curves of NH48120abcB-21XXX for $T_C = 110^\circ\text{C}$

METAL ENCLOSED PACKAGE

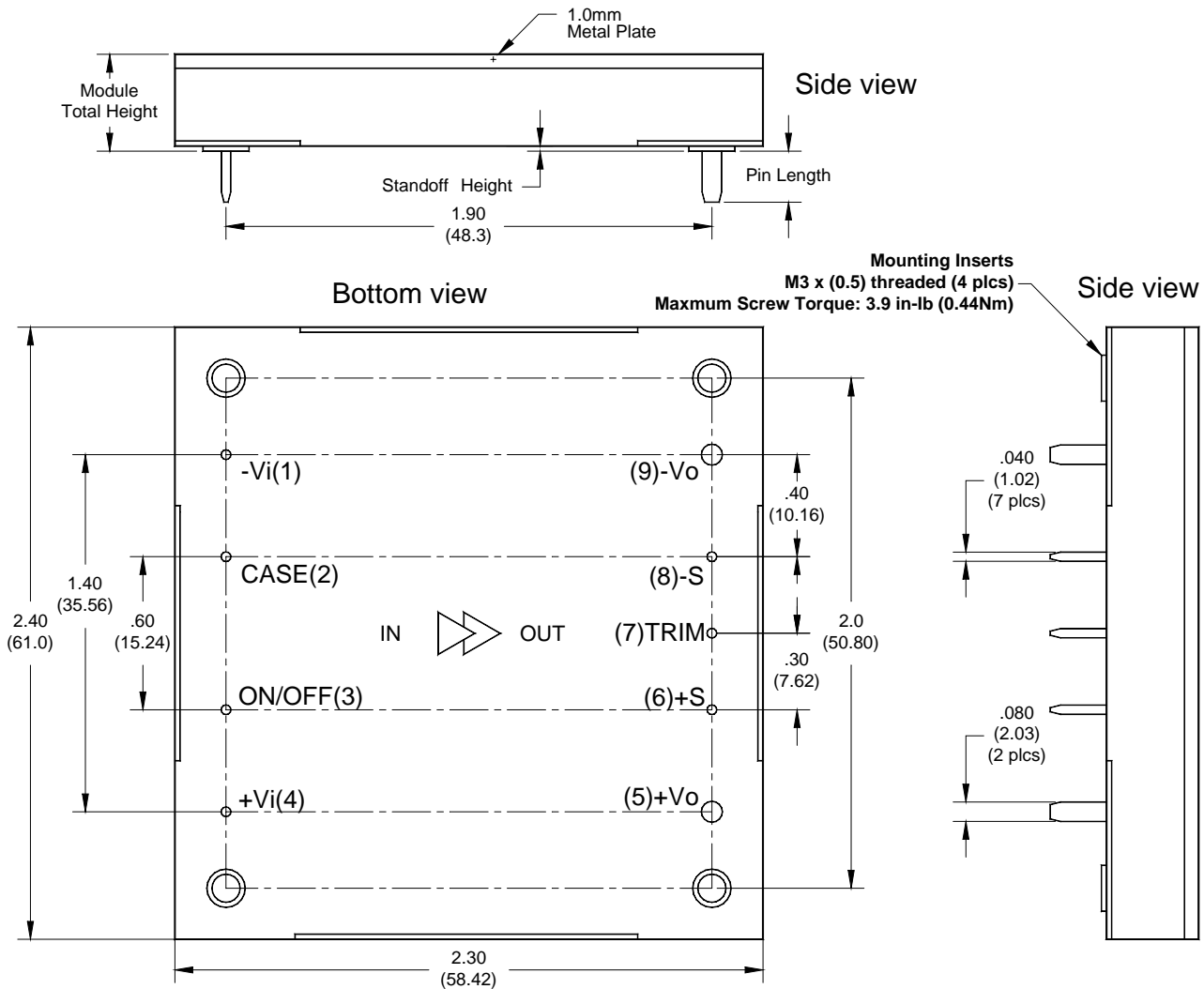

Dimensions and Pin Connections

Designation	Function Description	Pin #
-Vi	Negative input	1
CASE	Connected to base plate	2
ON/OFF	Remote control. To turn-on and turn-off output.	3
+Vi	Positive input	4
+Vo	Positive output	5
+S	Positive remote sense	6
TRIM	Output voltage adjust	7
-S	Negative remote sense	8
-Vo	Negative output	9

Dimensions: inches (mm)

Tolerances: .xx±0.02 (.x±0.5)
 .xxx±0.01 (.x±0.25)

Weight: 95g / 1.0mm metal plate

Base plate: Aluminum alloy with anode oxide

Mounting inserts: Stainless steel

Maximum torque: 3.9 in-lb (0.44Nm)

Pin material: Copper alloy or Brass

Pin plating: Golden over Nickel

OPEN FRAME PACKAGE

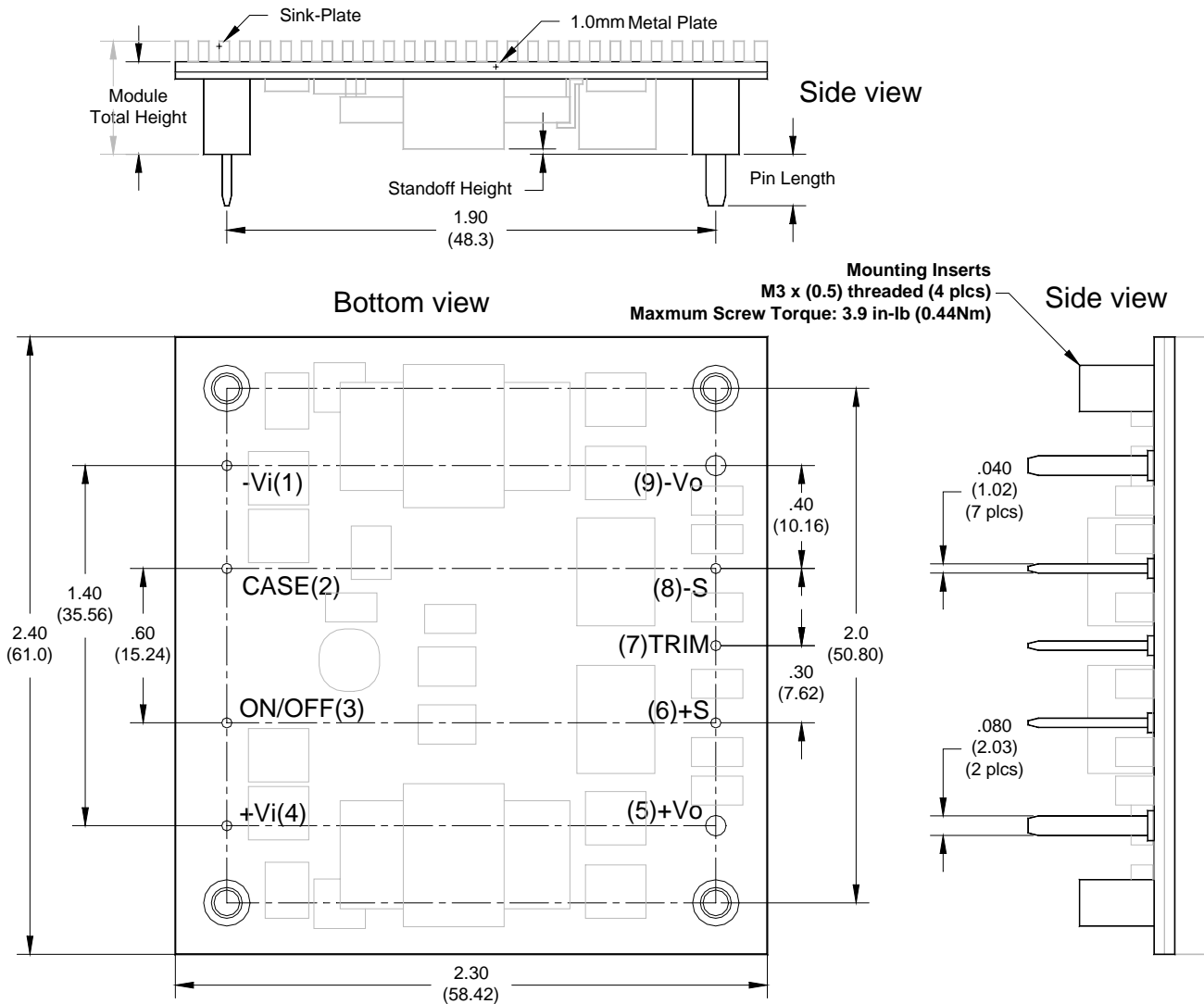

Dimensions and Pin Connections

Designation	Function Description	Pin #
-Vi	Negative input	1
CASE	Connected to base plate	2
ON/OFF	Remote control. To turn-on and turn-off output.	3
+Vi	Positive input	4
+Vo	Positive output	5
+S	Positive remote sense	6
TRIM	Output voltage adjust	7
-S	Negative remote sense	8
-Vo	Negative output	9

Dimensions: inches (mm)

Tolerances: .xx±0.02 (.x±0.5)
.xxx±0.01 (.x±0.25)

Weight: 60g / 1.0mm metal plate

Base plate: Aluminum alloy with anode oxide

Mounting inserts: Stainless steel

Maximum torque: 3.9 in-lb (0.44Nm)

Pin material: Copper alloy or Brass

Pin plating: Golden over Nickel

REFERENCED EMC CIRCUIT

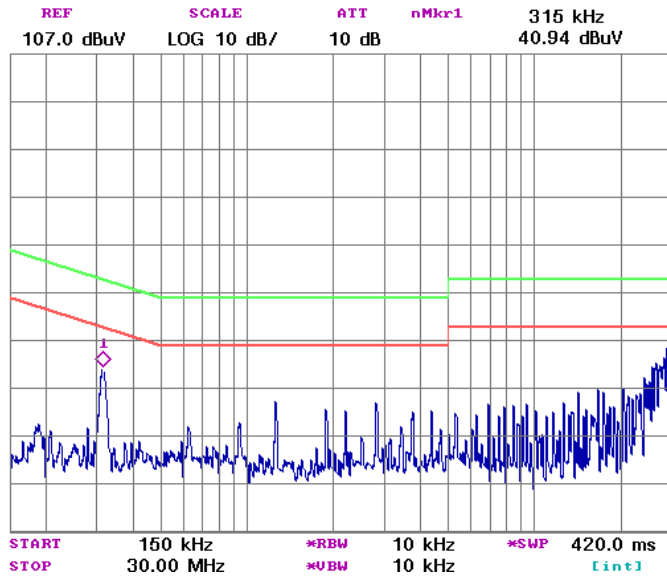

Referenced EMC Performance

The tested result shown in left-hand side is obtained by loading the power module with a resistive load only. It can be used as a design reference for customer system. However! The performance of customer's system depends on the whole system design. It should be noted that modifications on the circuit parameters and fine adjustment of the final layout affect the final EMC performance greatly.

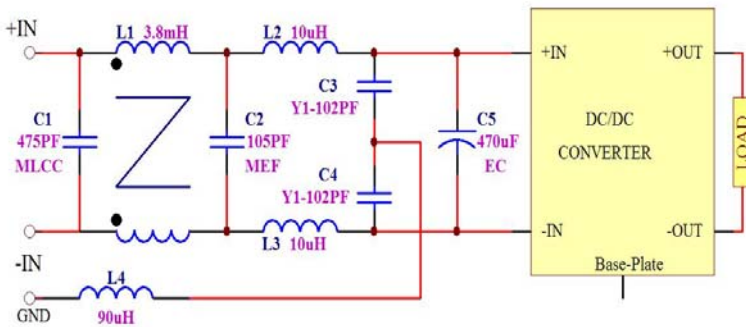

Measured conductive level of NH48280abcd-11XXX and referenced filter circuit

Bandwidth of EMC Components

No components are ideal for infinite frequency range. The bandwidth of EMC components should be taking into consideration when designing an EMC filter circuit. To connect ceramic capacitor with electricity capacitor in parallel and connect low inductance inductor with big one could get a better bandwidth.

NOTE:

1. It is recommended that the input should be protected by fuses or other protection devices.
2. All specifications are typical at nominal input, full load and 25°C unless otherwise noted.
3. Specifications are subject to change without notice.
4. Printed or downloaded datasheets are not subject to Glary document control.
5. Product labels shown, including safety agency certificates, may vary based on the date of manufacture.
6. Information provided in this documentation is for ordering purposes only.
7. This product is not designed for use in critical life support systems, equipment used in hazardous environments, nuclear control systems or other such applications, which necessitate specific safety and regulatory standards other than the ones listed in this datasheet.

IMPORTANT

- ✳ General specifications and the performances are related to standard series only, no special customer specification display here except requested items.
- ✳ In order to secure effective usage of converter and the validity of Glary's service and warranty coverage, please refer to the application notes for general usage. For needs of usage beyond the application notes, please contact to Glary headquarter or our regional sales representative office for help.

Efficiency >90%	100W/in ³	Open Frame Package	OCP	6.4Mhrs MTBF
Remote ON OFF	INPUT 2:1	OVP	OTP	



The high efficiency **Neat** Converter family provides up to 50W/12A output with 1/32 and 1/16 brick packages, which is designed with the efficiently patented “Coupled-Inductor SR” topology. The low profile module design with open frame package reduces the shadow effect and provides the advanced thermal performance to simplify the system power design for users.

PART NUMBER SYSTEM

NS	48	050	a	b	c	d	-	10	XX	X
Series Name	Input Voltage	Output Voltage	Enable Logic	Pin Dimension	Standoff Height	Base-Plate		Output Current	Suffix	Version
NS N32	48=36V~75V 24=18V~36V	Unit: 0.1V Increments 120=12V 050=5V	P: Positive N: Negative	0 : 0.12" 1 : 0.16" 2 : 0.20"	0 : 0.02"	O : Open frame standard type	-	00~12 : For output current rating	For marketing purpose only	

MODEL LIST (Contact to factory for special input / output)

Part Number *	Maximum Input	Maximum Output	Efficiency	Part Number *	Maximum Input	Maximum Output	Efficiency				
N3224120abcd-03XXX	18V~36V	44W	12.0V/3.3A	40W	92%	NS24120abcd-04XXX	18V~36V	55W	12.0V/4.2A	50W	91%
N3224050abcd-08XXX	18V~36V	45W	5.0V/8A	40W	90%	NS24050abcd-10XXX	18V~36V	56W	5.0V/10A	50W	90%
N3224033abcd-10XXX	18V~36V	37W	3.3V/10A	33W	89%	NS24033abcd-12XXX	18V~36V	45W	3.3V/12A	40W	88%
N3224025abcd-10XXX	18V~36V	29W	2.5V/10A	20W	87%	NS24025abcd-12XXX	18V~36V	35W	2.5V/12A	30W	86%
N3248120abcd-03XXX	36V~75V	44W	12.0V/3.3A	40W	91%	NS48120abcd-04XXX	36V~75V	55W	12.0V/4.2A	50W	90%
N3248050abcd-08XXX	36V~75V	45W	5.0V/8A	40W	89%	NS48050abcd-10XXX	36V~75V	56W	5.0V/10A	50W	89%
N3248033abcd-10XXX	36V~75V	37W	3.3V/10A	33W	88%	NS48033abcd-12XXX	36V~75V	45W	3.3V/12A	40W	87%
N3248025abcd-10XXX	36V~75V	29W	2.5V/10A	20W	86%	NS48025abcd-12XXX	36V~75V	35W	2.5V/12A	30W	85%

REFERENCED THERMAL IMAGES

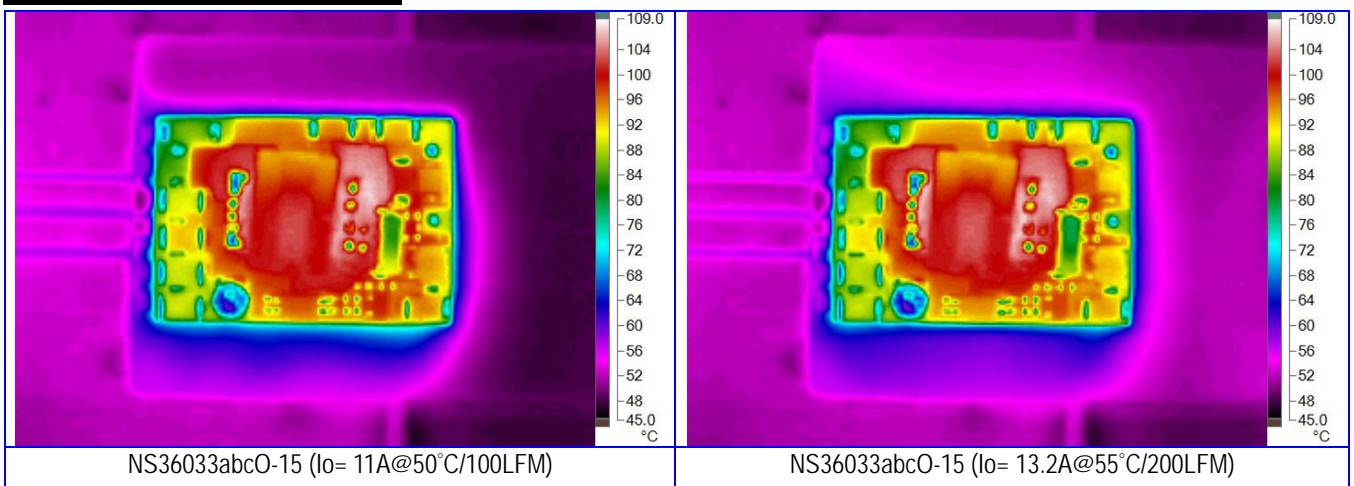

SPECIFICATIONS

Absolute Maximum Ratings		
Temperature	Operation Storage	-40°C to +110°C -55°C to +125°C
Input Voltage Range	Operation: 24V Models 48V Models Transient (100mS): 24V Models 48V Models	-0.5V to +40Vdc -0.5V to +80Vdc 50V Maximum 100V Maximum
Isolation Voltage	Input to Output	2.0KV Minimum
Remote Control		-0.5V to +12Vdc

General Parameters		
Conversion Efficiency	Typical	See table
Switching Frequency	Typical	400KHz
MTBF	Bellcore TR-332 issue 6	6.4×10 ⁶ hrs @GB/25°C (NT48050abcd-10XXX)
OTP	Internal	110°C(Tc) ±5°C
Weight	1/32 Brick 1/16 Brick	8g 10g

Control Functions		
Remote Control	Logic High Logic Low	+3.0V to +6.5V 0V to +1.0V
Input Current of Remote Control Pin		-0.5mA ~ +1.5mA

Input		
Operation Voltage Range	24V Models 48V Models	+18V to +36Vdc +36V to +75Vdc
Reflected Ripple Current	L _{EXT} = 10uH	30mA rms/100mAp-p
Power ON Voltage Ranges	24V Models 48V Models	+17.0V to +18.0Vdc +34.0V to +36.0Vdc
Power OFF Voltage Ranges	24V Models 48V Models	+15.6V to +16.6Vdc +31.2V to +33.2Vdc
Off State Input Current	V _{NOM}	3mA Max
Latch-State Input Current	V _{NOM}	8mA Max
Input Capacitance	24V Models 48V Models	15.0uF Max 6.0uF Max

Output		
Voltage Accuracy	Typical	±1.0%
Line Regulation	Full Input Range	±0.2%
Load Regulation	10%~100%	±0.2%
Temperature Drift	-40°C ~100°C	±0.03%/°C
Output Tolerance Band	All Conditions	±4%
Ripple & Noise (20MHz)	Peak-Peak (RMS)	3% (1%) V _O
Over Voltage Protection	V _{NOM} , 10% Load	115~130 %V _O
Output Current Limits	V _{NOM}	108%~125%
Voltage Trim	V _{NOM} , 10% Load	±10%
Input Ripple Rejection (<1KHz)	V _{NOM} , Full Load	-50dB
Step Load (2.5A/μS)	50%~75% Load	±6%Vo/500μS
Start-Up Delay Time	V _{NOM} , Full Load	20mS/250mS

TYPICAL WAVES AND CURVES

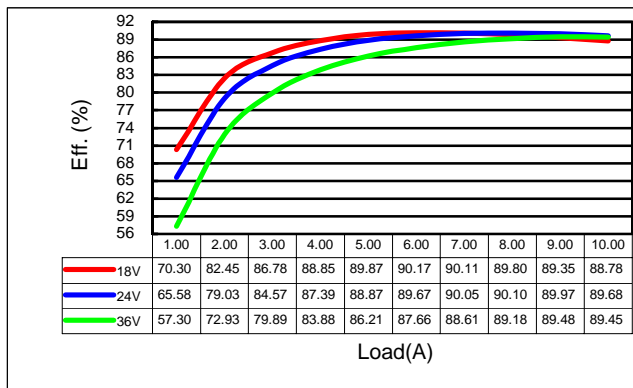
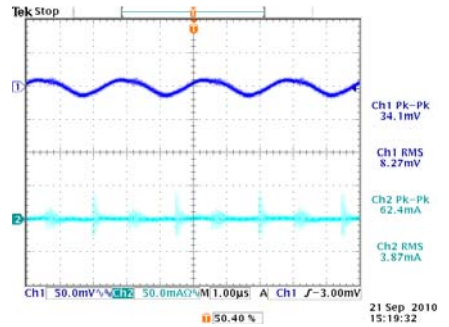
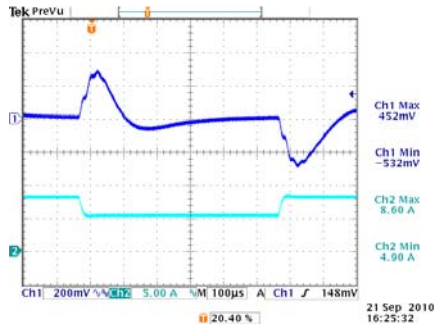
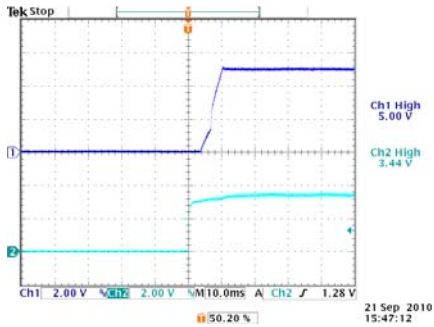

Efficiency plot of NS24050abcd-10XXX

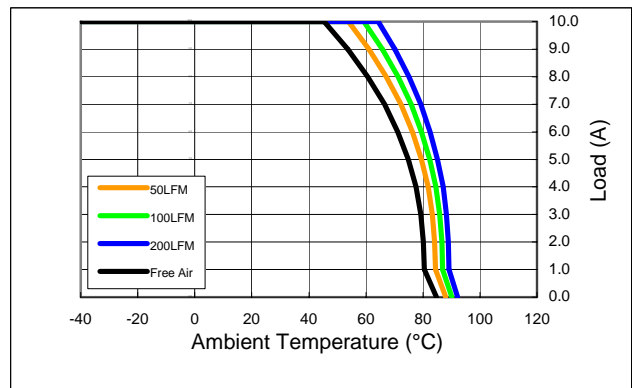

Derating curves of NS24050abcd-10XXX for T_C = 110°C

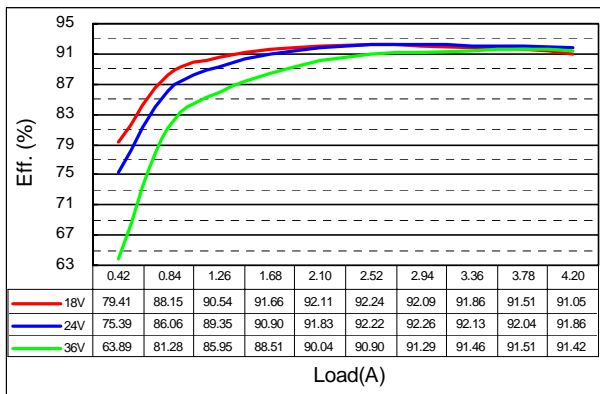
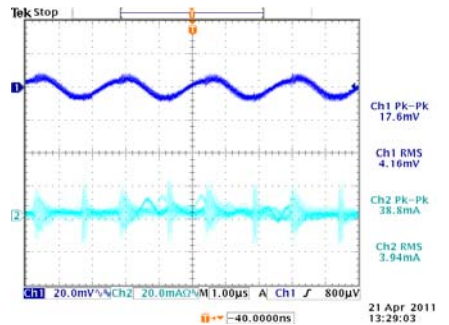
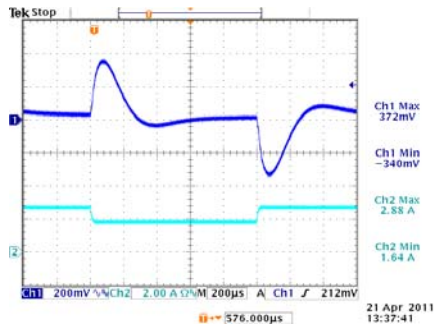
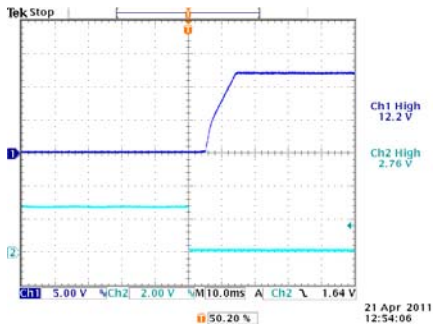

Efficiency plot of NS24120N000-04XXX

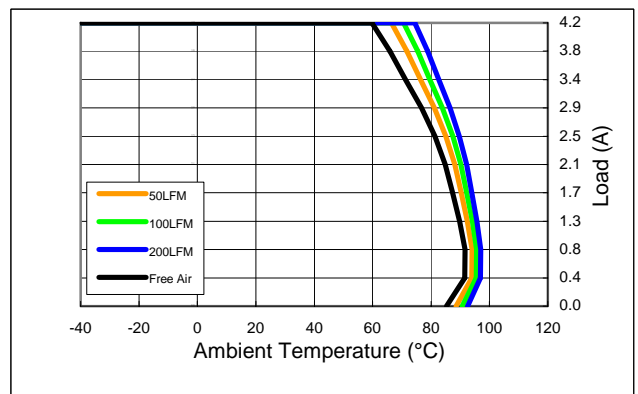

Derating curves of NS24120N000-04XXX for T_C = 110°C

OPEN FRAME PACKAGE

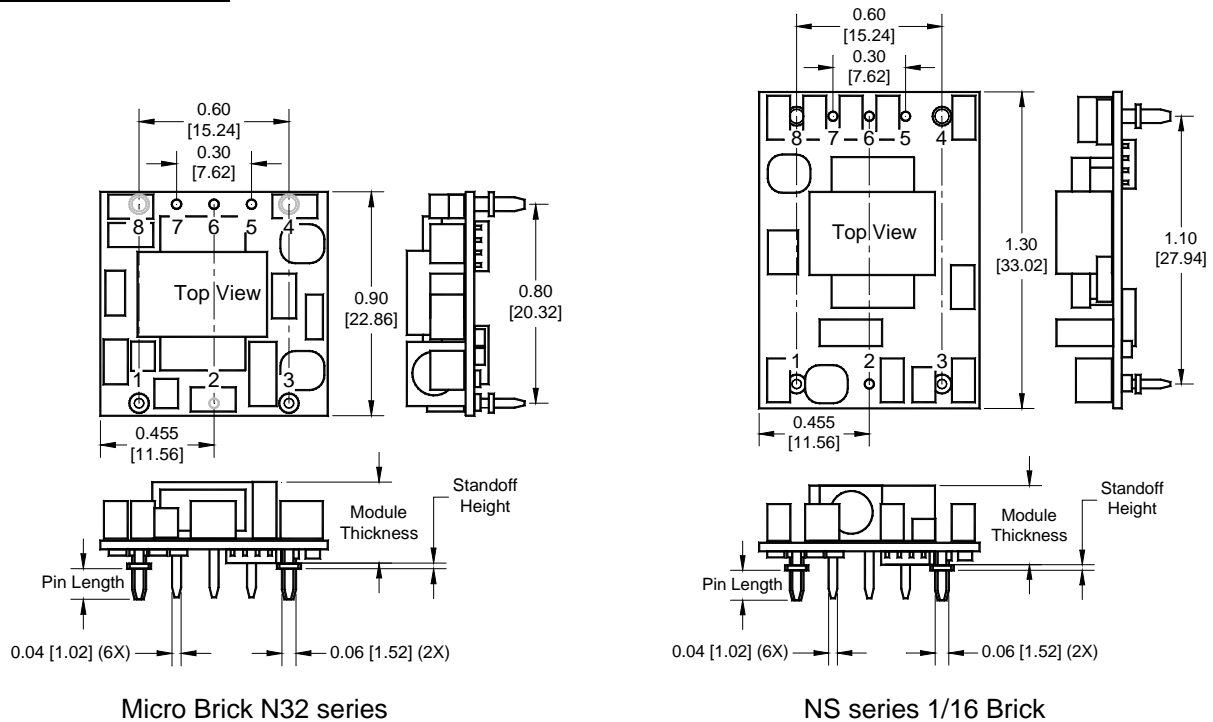

Dimensions and Pin Connections

Designation	Function Description	Pin #
+Vi	Positive input	1
Remote	ON/OFF control	2
-Vi	Negative input	3
-Vo	Negative output	4
-S	Negative remote sense	5
TRIM	Output voltage adjust	6
+S	Positive remote sense	7
+Vo	Positive output	8

Dimensions: inches (mm)

Tolerances: .xx±0.02 (.x±0.5)
.xxx±0.01 (.x±0.25)

Mass: 8g / Micro brick N32 series
10g / NS series 1/16 brick

Base plate: None

Pin material: Copper alloy or Brass

Pin plating: Golden over Nickel

NOTE:

1. It is recommended that the input should be protected by fuses or other protection devices.
2. All specifications are typical at nominal input, full load and 25°C unless otherwise noted.
3. Specifications are subject to change without notice.
4. Printed or downloaded datasheets are not subject to Glary document control.
5. Product labels shown, including safety agency certificates, may vary based on the date of manufacture.
6. Information provided in this documentation is for ordering purposes only.
7. This product is not designed for use in critical life support systems, equipment used in hazardous environments, nuclear control systems or other such applications, which necessitate specific safety and regulatory standards other than the ones listed in this datasheet.

IMPORTANT

- ✘ General specifications and the performances are related to standard series only, no special customer specification display here except requested items.
- ✘ In order to secure effective usage of converter and the validity of Glary's service and warranty coverage, please refer to the application notes for general usage. For needs of usage beyond the application notes, please contact to Glary headquarter or our regional sales representative office for help.

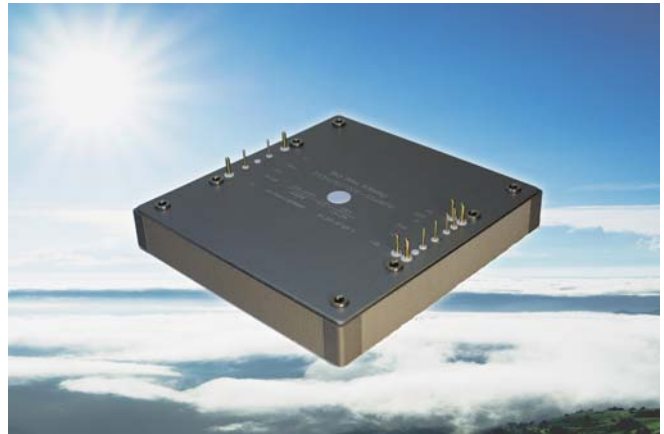

The **PowerSquare** series provides up to 2000W/120A outputs with industry standard full brick pin assignment. The high thermal conductivity silicone potted six-sides metal package is designed for applications under extreme environmental conditions. The efficient SR stage is combined with patented "Buck Reset" topology that would reduce power loss to achieve 102W/in³ power density. The multi-layer single side circuit board design plus the unique module structure would enhance the thermal performance and improve its reliability. Modules are designed for Industrial, Telecom, Servers, Networking equipments and other applications that use a 300V (200~400V) input bus.

PART NUMBER SYSTEM

PS	2H	480	a	b	c	d	-	N	42	XX	X
Series Name	Input Voltage	Output Voltage	Enable Logic	Pin Dimension	Standoff Height	Base-Plate		Current Share	Output Current	Suffix	Version
PS	200V~420V	Unit: 0.1V Increments 480=48V 120=12V	P: Positive N: Negative	0 : 0.12" 1 : 0.16" 2 : 0.20" 3 : 0.24"	0 : 0.04"	E : 1.5mm Metal Plate		N : without Current share S : secondary Current share	00~C0 : for output current rating	For marketing purpose only	

MODEL LIST (Contact to factory special input / output)

Part Number *	Maximum Input	Maximum Output	Efficiency
PS2H480abcd-N42XXX	200V-420V	2191W 48V/42A	2016W 92%
PS2H280abcd-N72XXX	200V-420V	2191W 28V/72A	2016W 92%
PS2H240abcd-N83XXX	200V-420V	2191W 24V/83A	2016W 92%
PS2H120abcd-NC0XXX	200V-420V	2191W 12V/120A	2016W 92%

REFERENCED THERMAL IMAGES

To be updated in next version	To be updated in next version
-------------------------------	-------------------------------

SPECIFICATIONS

Absolute Maximum Ratings		
Temperature	Operation Storage	-40°C to +110°C -55°C to +125°C
Input Voltage Range	Operation: 48V Models Transient (100mS): 48V Models	+190V to +420Vdc 450V Maximum
Isolation Voltage	Input to Output Input to Case Output to Case	3.0KV Minimum 1.5KV Minimum 1.0KV Minimum
Remote Control		-0.5V to +12Vdc

General Parameters		
Conversion Efficiency	Typical	See table
Switching Frequency	Typical	160KHz
MTBF	Bellcore TR-332 issue 6	1.55x10 ⁶ hrs @GB/25°C. (PS2H480abcd-N42XXX)
OTP	Internal	110°C(Tc) ±5°C
Weight	1.5mm metal plate	870g

Control Functions		
Remote Control	Logic High Logic Low	+3.0V to +6.5V 0V to +1.0V
Input Current of Remote Control Pin		-0.5mA ~ +1.5mA

Input		
Operation Voltage Range	300V Models	+200V to +400Vdc
Reflected Ripple Current	L _{EXT} = 20uH	30mA rms/200mAp-p
Input Over Voltage Protection		+435Vmax.
Turn-On Voltage Threshold	300V Models	+190V to +198Vdc
Turn-Off Voltage Threshold	300V Models	+185V to +194Vdc
Off State Input Current	V _{NOM}	12mA Max
Latch-State Input Current	V _{NOM}	20mA Max
Input Capacitance	300V Models	10.0uF Max

Output		
Voltage Accuracy	Typical	±1.0%
Line Regulation	Full Input Range	±0.3%
Load Regulation	5%~100%	±0.3%
Temperature Drift	-40°C ~100°C	±0.03%/°C
Output Tolerance Band	All Conditions	±4%
Ripple & Noise (20MHz)	Peak-Peak (RMS)	3% (1%) V _O
Over Voltage Protection	V _{NOM} , 10% Load	115~130 %V _O
Output Current Limits	V _{NOM}	108%~125%
Voltage Trim	V _{NOM} , 10% Load	±10%
Input Ripple Rejection (<1KHz)	V _{NOM} , Full Load	-50dB
Step Load (2.5A/μS)	50%~75% Load	±6%Vo/500μS
Start-Up Delay Time	V _{NOM} , Full Load	100mS/250mS

TYPICAL WAVES AND CURVES

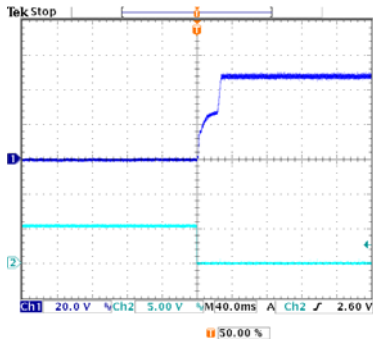

Start-up waveform of PS2H480abcd-S32XXX
(V_{IN} : 270V, Load: 32A)

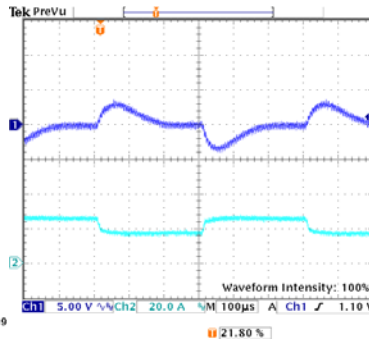

Transient response of PS2H480abcd-S32XXX
(V_{IN} : 270V, Load: 28A/15A@2.5A/ μ S)

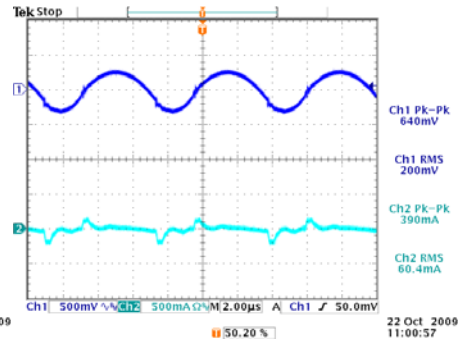

Input/Output ripples of PS2H480abcd-S32XXX
(V_{IN} : 270V, Load: 32A, L_{IN} =10uH)

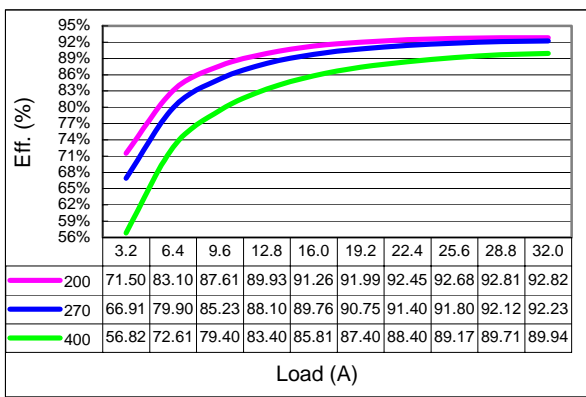

Efficiency plot of PS2H480abcd-S32XXX

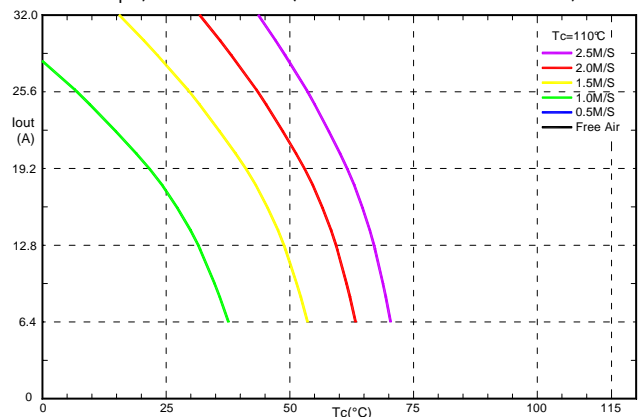

Derating curves of PS2H480abcd-S32XXX for $T_C = 110^\circ\text{C}$

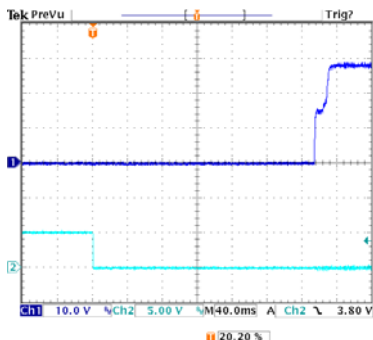

Start-up waveform of PS2H280abcd-S54XXX
(V_{IN} : 270V, Load: 54A)

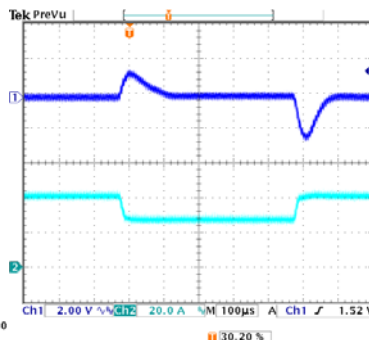

Transient response of PS2H280abcd-S54XXX
(V_{IN} : 270V, Load: 45A/24A@2.5A/ μ S)

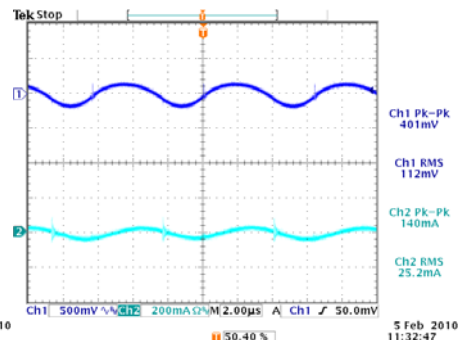

Input/Output ripples of PS2H280abcd-S54XXX
(V_{IN} : 270V, Load: 54A, L_{IN} =10uH)

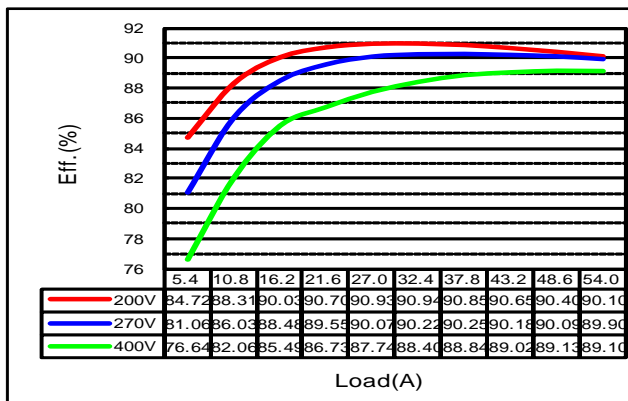

Efficiency plot of PS2H280abcd-S54XXX

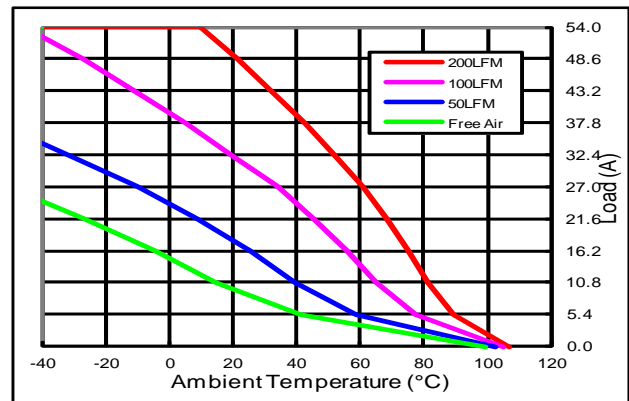

Derating curves of PS2H280abcd-S54XXX for $T_C = 110^\circ\text{C}$

METAL ENCLOSED PACKAGE

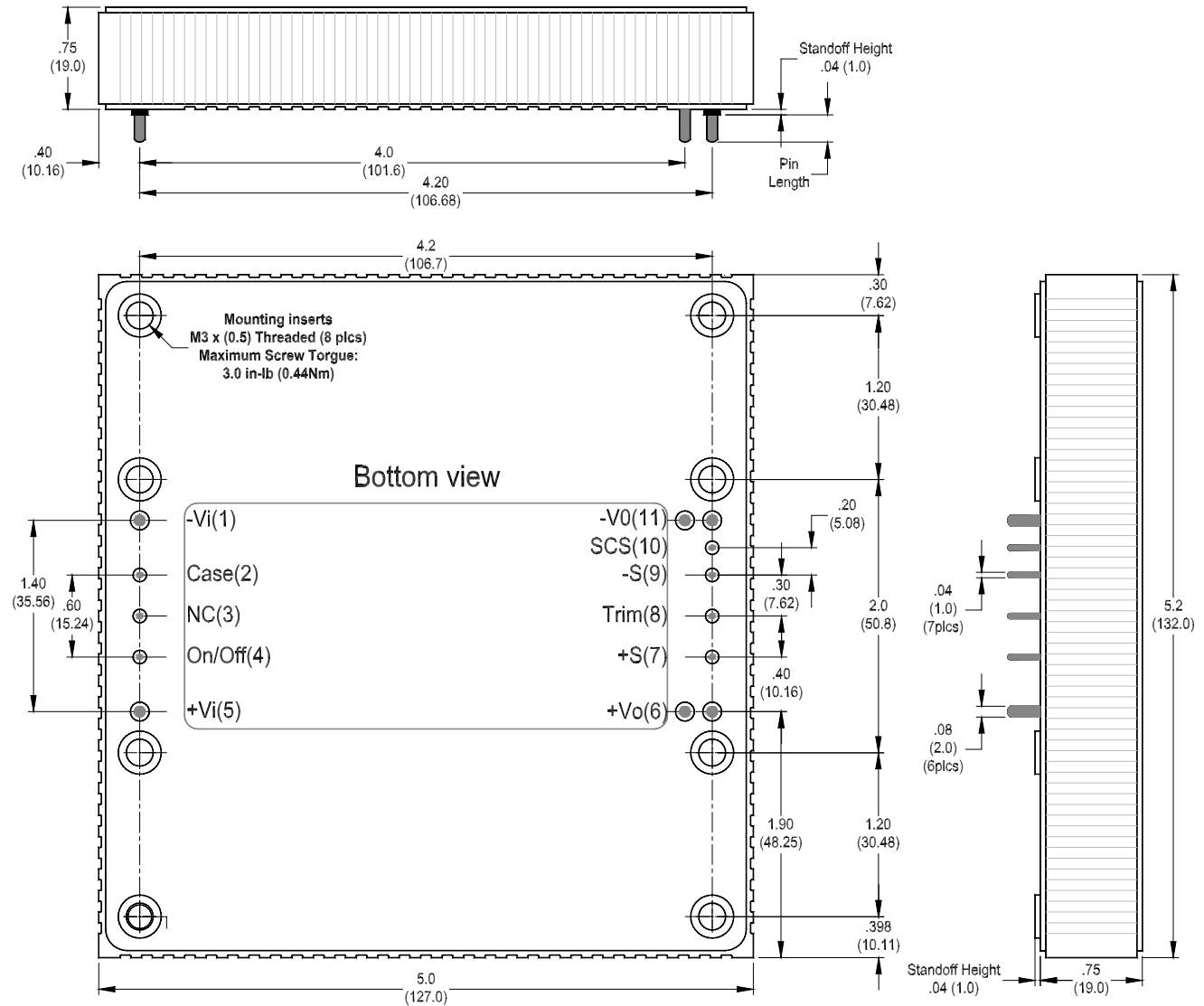

Dimensions and Pin Connections

Designation	Function Description	Pin #
-Vi	Negative input	1
CASE	Connected to base plate	2
NC	No connection	3
ON/OFF	Remote control. To turn-on and turn-off output.	4
+Vi	Positive input	5
+Vo	Positive output	6
+S	Positive remote sense	7
TRIM	Output voltage adjust	8
-S	Negative remote sense	9
SCS	Secondary current share bus	10
-Vo	Negative output	11

Dimensions: inches (mm)

Tolerances: .xx±0.02 (.x±0.5)
 .xxx±0.01 (.x±0.25)

Weight: 870g

Base plate: Aluminum alloy with anode oxide

Mounting inserts: Stainless steel
Maximum torque: 3.9 in-lb (0.44Nm)

Pin material: Copper alloy or Brass

Pin plating: Golden over Nickel

REFERENCED EMC CIRCUIT

Referenced EMC Performance

The tested result shown in left-hand side is obtained by loading the power module with a resistive load only. It can be used as a design reference for customer system. However! The performance of customer's system depends on the whole system design. It should be noted that modifications on the circuit parameters and fine adjustment of the final layout affect the final EMC performance greatly.

To be updated in next version

Bandwidth of EMC Components

No components are ideal for infinite frequency range. The bandwidth of EMC components should be taking into consideration when designing an EMC filter circuit. To connect ceramic capacitor with electricity capacitor in parallel and connect low inductance inductor with big one could get a better bandwidth.

NOTE:

1. It is recommended that the input should be protected by fuses or other protection devices.
2. All specifications are typical at nominal input, full load and 25°C unless otherwise noted.
3. Specifications are subject to change without notice.
4. Printed or downloaded datasheets are not subject to Glary document control.
5. Product labels shown, including safety agency certificates, may vary based on the date of manufacture.
6. Information provided in this documentation is for ordering purposes only.
7. This product is not designed for use in critical life support systems, equipment used in hazardous environments, nuclear control systems or other such applications, which necessitate specific safety and regulatory standards other than the ones listed in this datasheet.

IMPORTANT

- ✘ General specifications and the performances are related to standard series only, no special customer specification display here except requested items.
- ✘ In order to secure effective usage of converter and the validity of Glary's service and warranty coverage, please refer to the application notes for general usage. For needs of usage beyond the application notes, please contact to Glary headquarter or our regional sales representative office for help.

Efficiency **>91%** **144W/in³** Full Metal Package **OCP** **2.23Mhrs MTBF**

Remote **ON OFF** **INPUT 2:1** **OVP** **OTP**



The **UH2H** series provides up to 504W/42A output with industry standard half brick package. The efficient SR stage is combined with patented "Buck Reset" topology that would reduce power loss to achieve 144W/in³ power density. The multi-layer single side circuit board design plus the patented Sink-Plate technology would enhance the thermal performance and improve its reliability. Modules are designed for Telecom, Servers, Networking equipments and other applications that use a 300V (200~400V) input bus.

PART NUMBER SYSTEM

UH	2H	480	a	b	c	d	-	N	10	XX	X
Series Name	Input Voltage	Output Voltage	Enable Logic	Pin Dimension	Standoff Height	Base-Plate		Current Share	Output Current	Suffix	Version
UH	200V~420V	Unit: 0.1V Increments 480=48V 120=12V	P: Positive N: Negative	0 : 0.12" 1 : 0.16" 2 : 0.20" 3 : 0.24"	0 : 0.02"	E : 1.0mm Metal Plate		N : without Current share S : secondary Current share	00~A0 : for output current rating		For marketing purpose only

MODEL LIST (Contact to factory for special input / output)

Part Number *	Maximum Input	Maximum Output	Efficiency
UH2H480abcd-N10XXX	200V~420V 554W	48V/10.5A 504W	91%
UH2H280abcd-N18XXX	200V~420V 554W	28V/18.0A 504W	91%
UH2H120abcd-N42XXX	200V~420V 554W	12V/42.0A 404W	91%
UH2H480abcd-N10XXX	200V~420V 554W	48V/10.5A 504W	91%

REFERENCED THERMAL IMAGES

To be updated in next version	To be updated in next version
-------------------------------	-------------------------------

SPECIFICATIONS

Absolute Maximum Ratings		
Temperature	Operation Storage	-40°C to +110°C -55°C to +125°C
Input Voltage Range	Operation: 300V Models Transient (100mS): 300V Models	+190V to +420Vdc 450V Maximum
Isolation Voltage	Input to Output Input to Case Output to Case	3.0KV Minimum 1.5KV Minimum 1.0KV Minimum
Remote Control		-0.5V to +12Vdc

General Parameters		
Conversion Efficiency	Typical	See table
Switching Frequency	Typical	160KHz
MTBF	Bellcore TR-332 issue 6	2.23×10 ⁶ hrs @GB/25°C. (UH2H280abcd-N18XXX)
OTP	Internal	110°C(Tc) ±5°C
Weight	1.0mm metal plate	163g

Control Functions		
Remote Control	Logic High Logic Low	+3.0V to +6.5V 0V to +1.0V
Input Current of Remote Control Pin		-0.5mA ~ +1.5mA

Input		
Operation Voltage Range	300V Models	+200V to +400Vdc
Reflected Ripple Current	L _{EXT} = 20uH	30mA rms/200mAp-p
Input Over Voltage Protection		+435Vmax.
Turn-On Voltage Threshold	300V Models	+190V to +198Vdc
Turn-Off Voltage Threshold	300V Models	+185V to +194Vdc
Off State Input Current	V _{NOM}	8mA Max
Latch-State Input Current	V _{NOM}	12mA Max
Input Capacitance	300V Models	4.7uF Max

Output		
Voltage Accuracy	Typical	±1.0%
Line Regulation	Full Input Range	±0.3%
Load Regulation	5%~100%	±0.3%
Temperature Drift	-40°C ~100°C	±0.03%/°C
Output Tolerance Band	All Conditions	±4%
Ripple & Noise (20MHz)	Peak-Peak (RMS)	3% (1%) V _O
Over Voltage Protection	V _{NOM} , 10% Load	115~130 %V _O
Output Current Limits	V _{NOM}	108%~125%
Voltage Trim	V _{NOM} , 10% Load	±10%
Input Ripple Rejection (<1KHz)	V _{NOM} , Full Load	-50dB
Step Load (2.5A/μS)	50%~75% Load	±6%Vo/500μS
Start-Up Delay Time	V _{NOM} , Full Load	100mS/250mS

TYPICAL WAVES AND CURVES

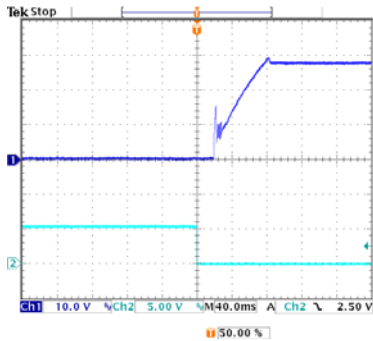

Start-up waveform of UH2H280abcd-S18XXX
(V_{IN} : 270V, Load: 18A) (External CAP100uF/100V)

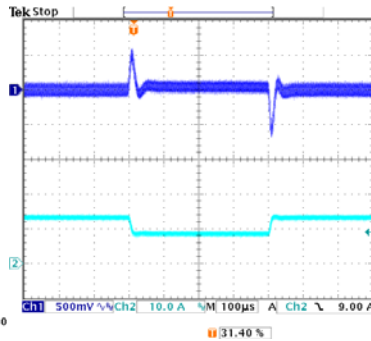

Transient response of UH2H280abcd-S18XXX
(V_{IN} : 270V, Load: 14.5A/7.5A@2.5A/µS)
(External CAP100uF/100V)

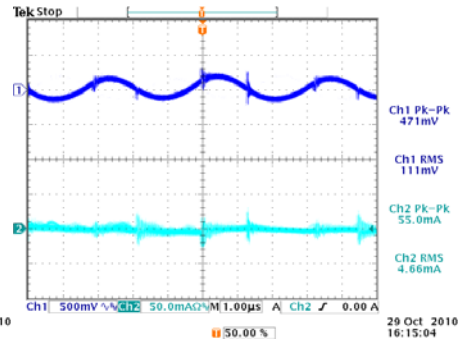

Input/Output ripples of UH2H280abcd-S18XXX
(V_{IN} : 270V, Load: 18A, L_{IN} =20uH, C_{IN} =270uF)
(External CAP100uF/100V)

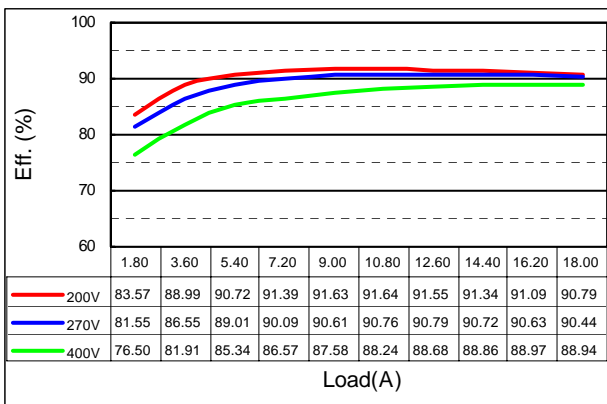

Efficiency plot of UH2H280abcE-S18XXX

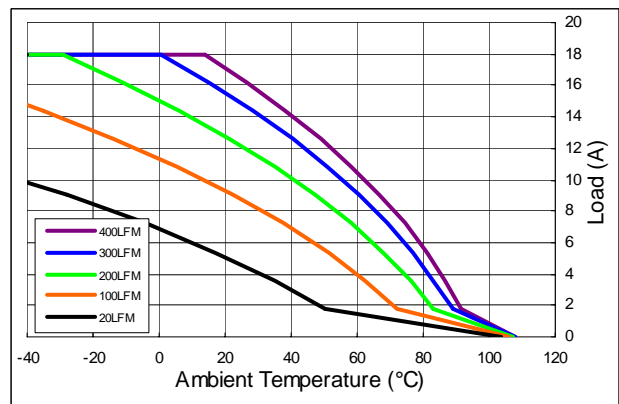

Derating curves of UH2H280abcE-S18XXX for $T_C=110^\circ\text{C}$

METAL ENCLOSED PACKAGE

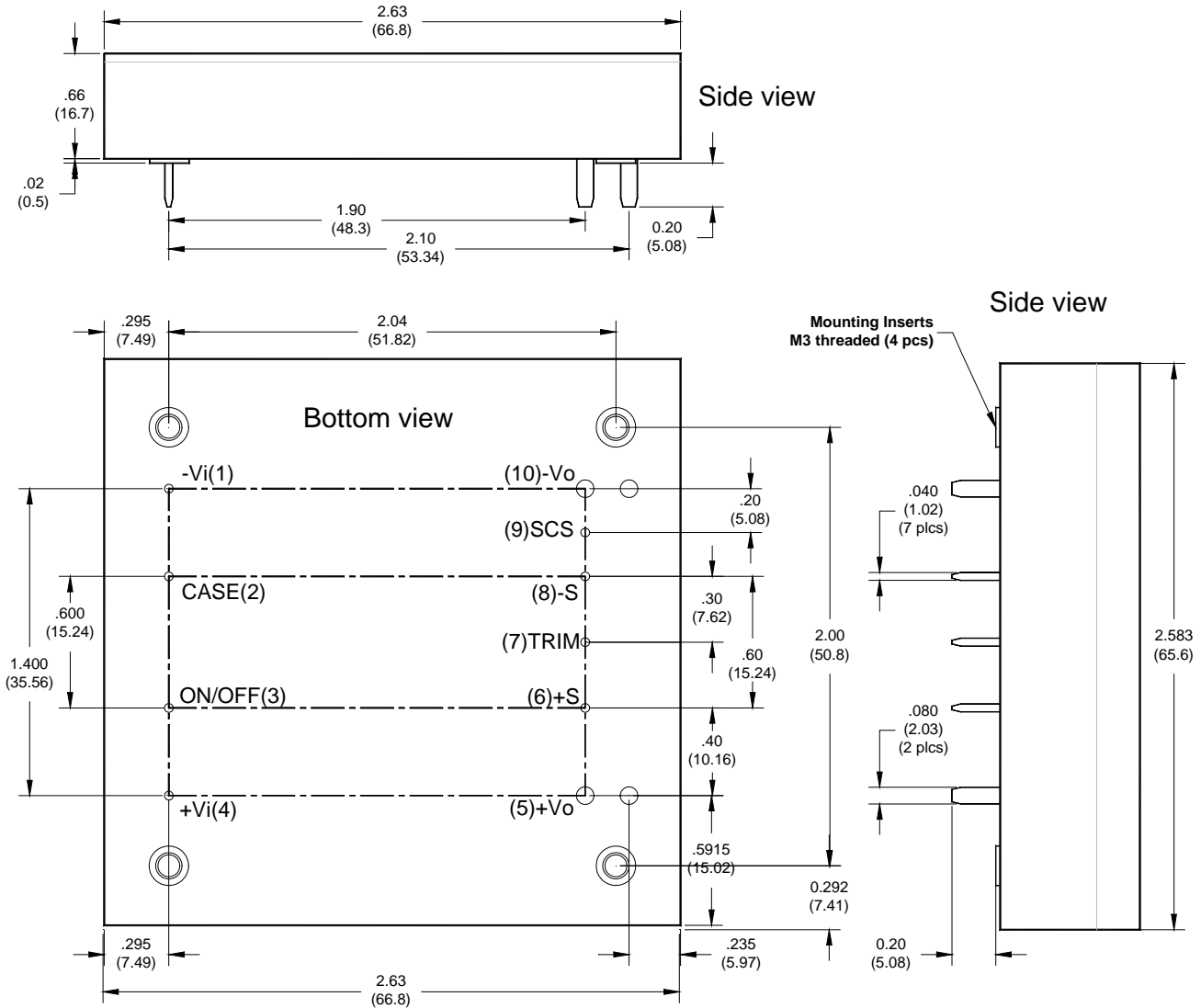

Dimensions and Pin Connections

Designation	Function Description	Pin #
-Vi	Negative input	1
CASE	Connected to base plate	2
ON/OFF	Remote control. To turn-on and turn-off output.	3
+Vi	Positive input	4
+Vo	Positive output	5
+S	Positive remote sense	6
TRIM	Output voltage adjust	7
-S	Negative remote sense	8
SCS	Secondary current share bus	9
-Vo	Negative output	10

Dimensions: inches (mm)

Tolerances: .xx±0.02 (.x±0.5)
.xxx±0.01 (.x±0.25)

Weight: 163g

Base plate: Aluminum alloy with anode oxide

Mounting inserts: Stainless steel

Maximum torque: 3.9 in-lb (0.44Nm)

Pin material: Copper alloy or Brass

Pin plating: Golden over Nickel

REFERENCED EMC CIRCUIT

Referenced EMC Performance

The tested result shown in left-hand side is obtained by loading the power module with a resistive load only. It can be used as a design reference for customer system. However! The performance of customer's system depends on the whole system design. It should be noted that modifications on the circuit parameters and fine adjustment of the final layout affect the final EMC performance greatly.

To be updated in next version

Bandwidth of EMC Components

No components are ideal for infinite frequency range. The bandwidth of EMC components should be taking into consideration when designing an EMC filter circuit. To connect ceramic capacitor with electricity capacitor in parallel and connect low inductance inductor with big one could get a better bandwidth.

NOTE:

1. It is recommended that the input should be protected by fuses or other protection devices.
2. All specifications are typical at nominal input, full load and 25°C unless otherwise noted.
3. Specifications are subject to change without notice.
4. Printed or downloaded datasheets are not subject to Glary document control.
5. Product labels shown, including safety agency certificates, may vary based on the date of manufacture.
6. Information provided in this documentation is for ordering purposes only.
7. This product is not designed for use in critical life support systems, equipment used in hazardous environments, nuclear control systems or other such applications, which necessitate specific safety and regulatory standards other than the ones listed in this datasheet.

IMPORTANT

- ✘ *General specifications and the performances are related to standard series only, no special customer specification display here except requested items.*
- ✘ *In order to secure effective usage of converter and the validity of Glary's service and warranty coverage, please refer to the application notes for general usage. For needs of usage beyond the application notes, please contact to Glary headquarter or our regional sales representative office for help.*

Efficiency >92% 219W/in³ Open Frame Package OCP 2.5Mhrs MTBF

Remote ON/OFF INPUT 2:1 OVP OTP

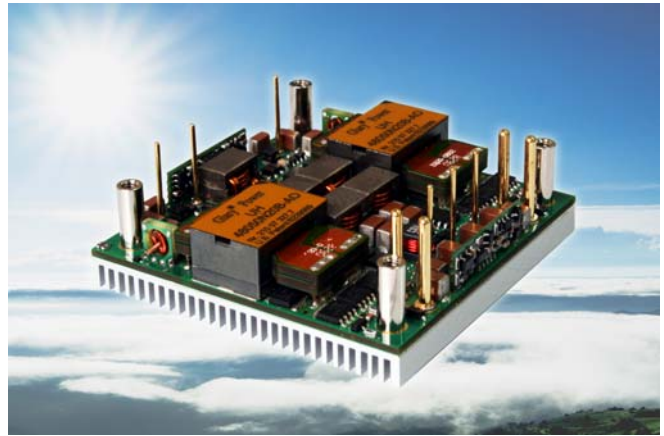

The **UH** series provides up to 800W/67A outputs with industry standard half brick package. The efficient SR stage is combined with patented "Buck Reset" topology that would reduce power loss to achieve 219W/in³ power density. The multi-layer single side circuit board design plus the patented Sink-Plate technology would enhance the thermal performance and improve its reliability. Modules are designed for Telecom, Servers, Networking equipments and other applications that use a 48V input bus.

PART NUMBER SYSTEM

UH	48	480	a	b	c	d	-	N	17	XX	X
Series Name	Input Voltage	Output Voltage	Enable Logic	Pin Dimension	Standoff Height	Base-Plate		Current Share	Output Current	Suffix	Version
UH	48=36V~75V 24=18V~36V	Unit: 0.1V Increments 480=48V 120=12V	P: Positive N: Negative	0 : 0.12" 1 : 0.16" 2 : 0.20" 3 : 0.24"	0 : 0.02" 1 : 0.08" 2 : 0.16"	M: 1.0mm Metal Plate A: 3.0mm Sink-Plate B: 5.0mm Sink-Plate		N : without Current share S : secondary Current share	00~C0 : for output current rating		For marketing purpose only

MODEL LIST (Contact to factory for special input / output)

Part Number *	Maximum Input		Maximum Output		Efficiency
UH48480abcd-N17XX0	36V~75V	887W	48V/17A	816W	92%
UH48280abcd-N29XX0	36V~75V	883W	28V/29A	812W	92%
UH48120abcd-N67XX0	36V~75V	874W	12V/67A	804W	92%

REFERENCED THERMAL IMAGES

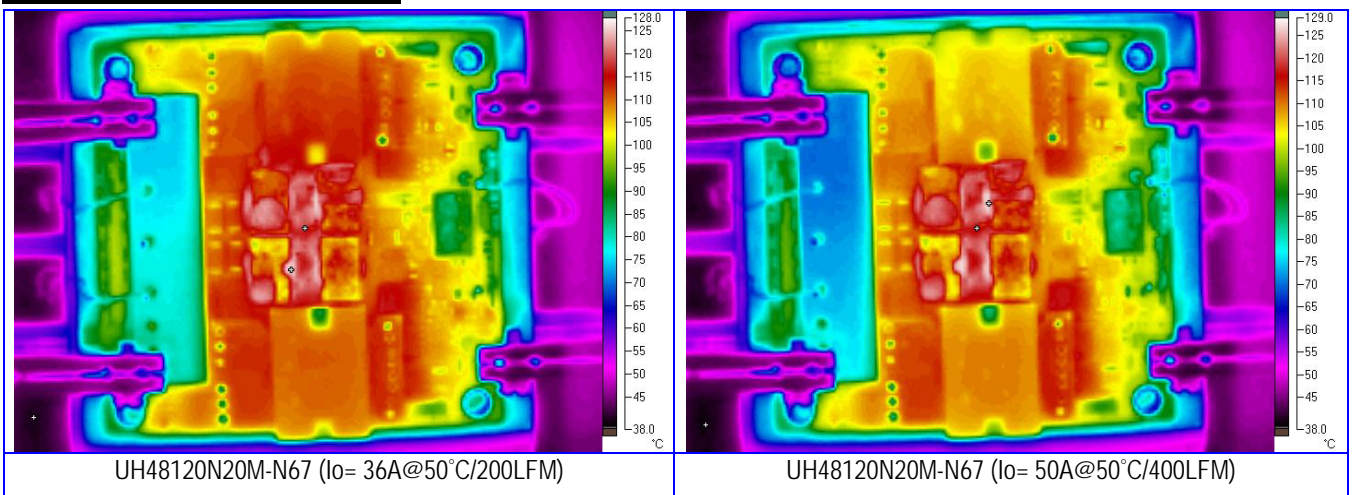

SPECIFICATIONS

Absolute Maximum Ratings		
Temperature	Operation Storage	-40°C to +110°C -55°C to +125°C
Input Voltage Range	Operation: 48V Models	-0.5V to +80Vdc
	Transient (100mS): 48V Models	100V Maximum
Isolation Voltage	Input to Output Input to Case Output to Case	2.0KV Minimum 1.0KV Minimum 1.0KV Minimum
Remote Control		-0.5V to +12Vdc

General Parameters		
Conversion Efficiency	Typical	See table
Switching Frequency	Typical	330KHz
MTBF	Bellcore TR-332 issue 6	2.51×10 ⁶ hrs @GB/25°C (UH48280abcd-N29XXX)
OTP	Internal	110°C(Tc) ±5°C
Weight	1.0mm Metal Plate	87g
	3.0mm Sink Plate	94g

Control Functions		
Remote Control	Logic High Logic Low	+3.0V to +6.5V 0V to +1.0V
Input Current of Remote Control Pin		-0.5mA ~ +1.5mA

Input		
Operation Voltage Range	48V Models	+36V to +75Vdc
Reflected Ripple Current	L _{EXT} = 20uH	50mA rms/200mAp-p
Power ON Voltage Ranges	48V Models	+34.0V to +36.0Vdc
Power OFF Voltage Ranges	48V Models	+31.2V to +33.2Vdc
Off State Input Current	V _{NOM}	6mA Max
Latch-State Input Current	V _{NOM}	8mA Max
Input Capacitance	48V Models	22.0uF Max

Output		
Voltage Accuracy	Typical	±1.0%
Line Regulation	Full Input Range	±0.3%
Load Regulation	0%~100%	±0.3%
Temperature Drift	-40°C ~100°C	±0.03%/°C
Output Tolerance Band	All Conditions	±4%
Ripple & Noise (20MHz)	Peak-Peak (RMS)	3% (1%) V _O
Over Voltage Protection	V _{NOM} , 10% Load	115~130 %V _O
Output Current Limits	V _{NOM}	108%~125%
Voltage Trim	V _{NOM} , 10% Load	±10%
Input Ripple Rejection (<1KHz)	V _{NOM} , Full Load	-50dB
Step Load (2.5A/μS)	50%~75% Load	±6%Vo/500μS
Start-Up Delay Time	V _{NOM} , Full Load	50mS/250mS

TYPICAL WAVES AND CURVES

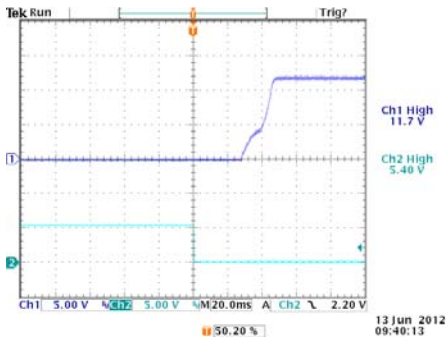

Start-up waveform of UH48120abcd-N67XXX
(V_{IN} : 48V, Load: 67A)

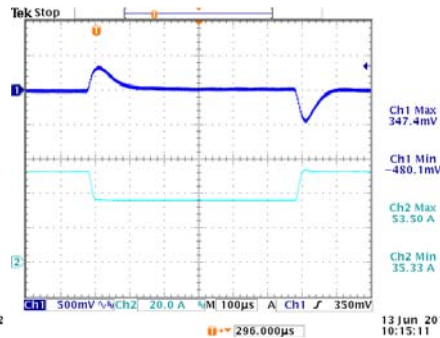

Transient response of UH48120abcd-N67XXX
(V_{IN} : 48V, Load: 53.5A/35.0A@2.5A/µs)

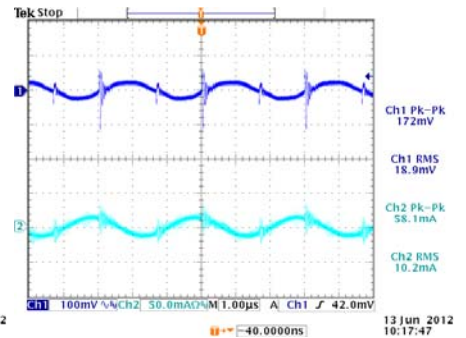

Input/Output ripples of UH48120abcd-N67XXX
(V_{IN} : 48V, Load: 67A, L_{IN} =10µH)

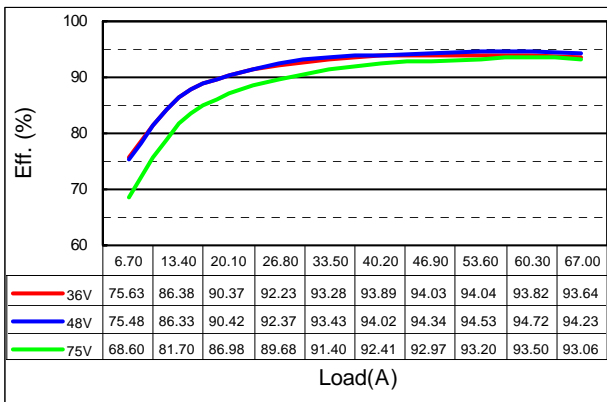

Efficiency plot of UH48120abcB-N67XXX

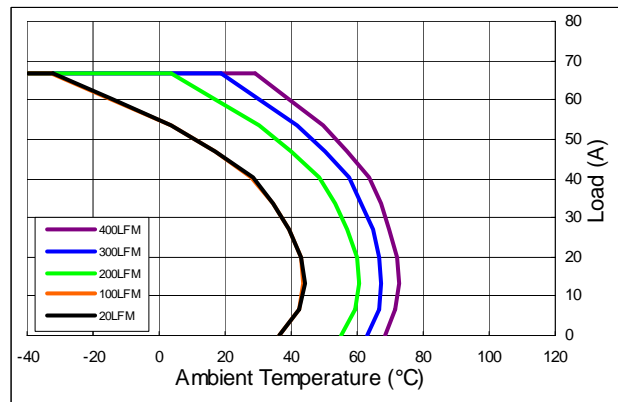

Derating curves of UH48120abcB-N67XXX for $T_C=110^\circ\text{C}$

OPEN FRAME PACKAGE

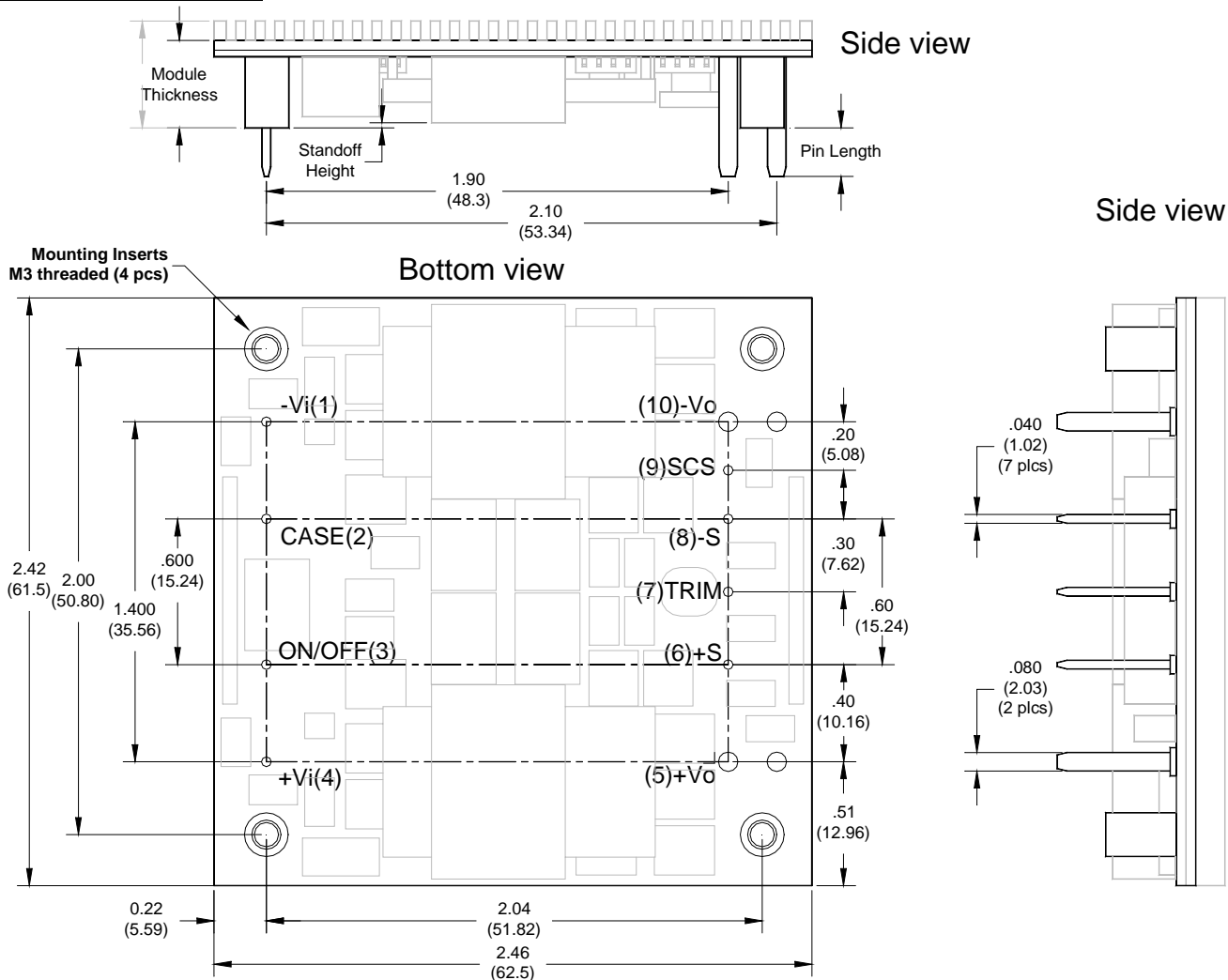

Dimensions and Pin Connections

Designation	Function Description	Pin #
-Vi	Negative input	1
CASE	Connected to base plate	2
ON/OFF	Remote control. To turn-on and turn-off output.	3
+Vi	Positive input	4
+Vo	Positive output	5
+S	Positive remote sense	6
TRIM	Output voltage adjust	7
-S	Negative remote sense	8
SCS	Secondary current share bus	9
-Vo	Negative output	10

Dimensions: inches (mm)

Tolerances: .xx±0.02 (.x±0.5)
.xxx±0.01 (.x±0.25)

Mass: 87g / 1.0mm Metal Plate
94g / 3.0mm Sink Plate

Base plate: Aluminum alloy with anode oxide

Mounting inserts: Stainless steel
Maximum torque: 3.9 in-lb (0.44Nm)

Pin material: Copper alloy or Brass

Pin plating: Golden over Nickel

REFERENCED EMC CIRCUIT

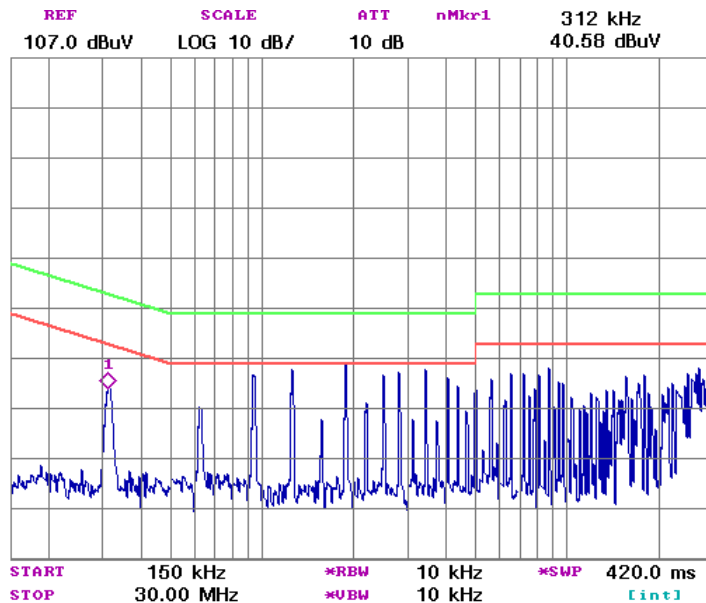

Referenced EMC Performance

The tested result shown in left-hand side is obtained by loading the power module with a resistive load only. It can be used as a design reference for customer system. However! The performance of customer's system depends on the whole system design. It should be noted that modifications on the circuit parameters and fine adjustment of the final layout affect the final EMC performance greatly.

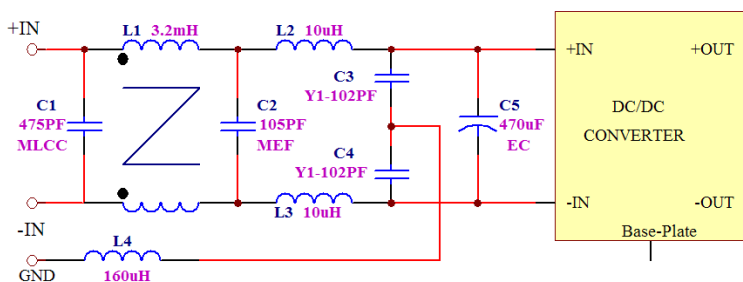

Measured conductive level of UH48120abcd-S50XXX and referenced filter circuit

Bandwidth of EMC Components

No components are ideal for infinite frequency range. The bandwidth of EMC components should be taking into consideration when designing an EMC filter circuit. To connect ceramic capacitor with electrolytic capacitor in parallel and connect low inductance inductor with big one could get a better bandwidth.

NOTE:

1. It is recommended that the input should be protected by fuses or other protection devices.
2. All specifications are typical at nominal input, full load and 25°C unless otherwise noted.
3. Specifications are subject to change without notice.
4. Printed or downloaded datasheets are not subject to Glary document control.
5. Product labels shown, including safety agency certificates, may vary based on the date of manufacture.
6. Information provided in this documentation is for ordering purposes only.
7. This product is not designed for use in critical life support systems, equipment used in hazardous environments, nuclear control systems or other such applications, which necessitate specific safety and regulatory standards other than the ones listed in this datasheet.

IMPORTANT

- * General specifications and the performances are related to standard series only, no special customer specification display here except requested items.
- * In order to secure effective usage of converter and the validity of Glary's service and warranty coverage, please refer to the application notes for general usage. For needs of usage beyond the application notes, please contact to Glary headquarter or our regional sales representative office for help.

Efficiency >92% 219W/in³ Open Frame Package OCP 2.5Mhrs MTBF

Remote ON/OFF INPUT 2:1 OVP OTP

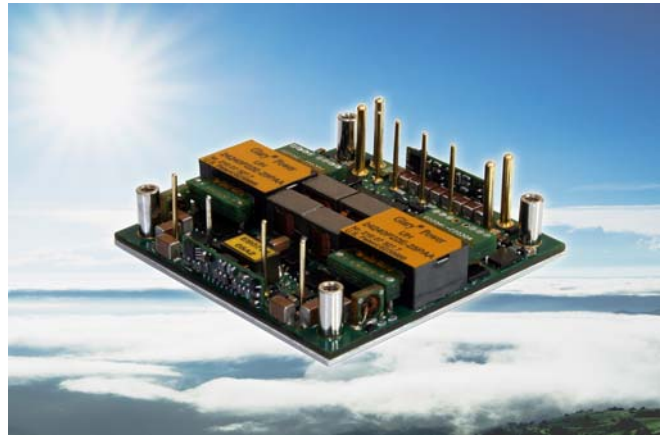

The **UH** series provides up to 600W/120A outputs with industry standard half brick package. The efficient SR stage is combined with patented "Buck Reset" topology that would reduce power loss to achieve 219W/in³ power density. The multi-layer single side circuit board design plus the patented Sink-Plate technology would enhance the thermal performance and improve its reliability. Modules are designed for Telecom, Servers, Networking equipments and other applications that use a 24V or 48V input bus.

PART NUMBER SYSTEM

UH	48	480	a	b	c	d	-	N	12	XX	X
Series Name	Input Voltage	Output Voltage	Enable Logic	Pin Dimension	Standoff Height	Base-Plate		Current Share	Output Current	Suffix	Version
UH	48=36V~75V 24=18V~36V	Unit: 0.1V Increments 480=48V 120=12V	P: Positive N: Negative	0 : 0.12" 1 : 0.16" 2 : 0.20" 3 : 0.24"	0 : 0.02" 1 : 0.08" 2 : 0.16"	M: 1.0mm Metal Plate A: 3.0mm Sink-Plate B: 5.0mm Sink-Plate		N : without Current share S : secondary Current share	00~C0 : for output current rating		For marketing purpose only

MODEL LIST (Contact to factory for special input / output)

Part Number *	Maximum Input	Maximum Output	Efficiency	Part Number *	Maximum Input	Maximum Output	Efficiency
UH48480abcd-N12XXX	36V~75V	627W	92%	UH24480abcd-N11XXX	18V~36V	548W	92%
UH48280abcd-N21XXX	36V~75V	640W	92%	UH48280abcd-N18XXX	18V~36V	548W	92%
UH48120abcd-N50XXX	36V~75V	653W	92%	UH24120abcd-N42XXX	18V~36V	548W	92%
UH48050abcd-NA0XXX	36V~75V	550W	91%	UH48050abcd-NA0XXX	18V~36V	550W	91%
UH48033abcd-NC0XXX	36V~75V	440W	90%	UH24033abcd-NC0XXX	18V~36V	440W	90%

REFERENCED THERMAL IMAGES

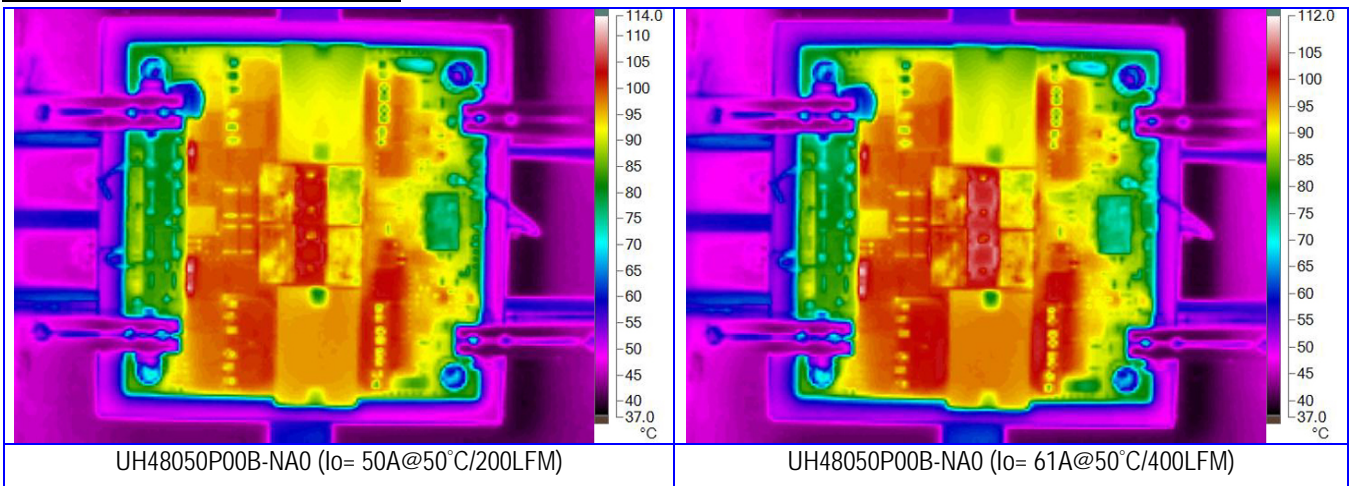

SPECIFICATIONS

Absolute Maximum Ratings		
Temperature	Operation Storage	-40°C to +110°C -55°C to +125°C
Input Voltage Range	Operation: 24V Models 48V Models Transient (100mS): 24V Models 48V Models	-0.5V to +40Vdc -0.5V to +80Vdc 50V Maximum 100V Maximum
Isolation Voltage	Input to Output Input to Case Output to Case	2.0KV Minimum 1.0KV Minimum 1.0KV Minimum
Remote Control		-0.5V to +12Vdc

General Parameters		
Conversion Efficiency	Typical	See table
Switching Frequency	Typical	300KHz
MTBF	Bellcore TR-332 issue 6	2.51×10 ⁶ hrs @GB/25°C (UH48050abcd-NA0XXX)
OTP	Internal	110°C(Tc) ±5°C
Weight	1.0mm Metal Plate 3.0mm Sink Plate	87g 94g

Control Functions		
Remote Control	Logic High Logic Low	+3.0V to +6.5V 0V to +1.0V
Input Current of Remote Control Pin		-0.5mA ~ +1.5mA

Input		
Operation Voltage Range	24V Models 48V Models	+18V to +36Vdc +36V to +75Vdc
Reflected Ripple Current	L _{EXT} = 10uH	80mA rms/300mAp-p
Power ON Voltage Ranges	24V Models 48V Models	+17.0V to +18.0Vdc +34.0V to +36.0Vdc
Power OFF Voltage Ranges	24V Models 48V Models	+15.6V to +16.6Vdc +31.2V to +33.2Vdc
Off State Input Current	V _{NOM}	6mA Max
Latch-State Input Current	V _{NOM}	8mA Max
Input Capacitance	24V Models 48V Models	48.0uF Max 20.0uF Max

Output		
Voltage Accuracy	Typical	±1.0%
Line Regulation	Full Input Range	±0.3%
Load Regulation	0%~100%	±0.3%
Temperature Drift	-40°C ~100°C	±0.03%/°C
Output Tolerance Band	All Conditions	±4%
Ripple & Noise (20MHz)	Peak-Peak (RMS)	3% (1%) V _O
Over Voltage Protection	V _{NOM} , 10% Load	115~130 %V _O
Output Current Limits	V _{NOM}	108%~125%
Voltage Trim	V _{NOM} , 10% Load	±10%
Input Ripple Rejection (<1KHz)	V _{NOM} , Full Load	-50dB
Step Load (2.5A/μS)	50%~75% Load	±6%Vo/500μS
Start-Up Delay Time	V _{NOM} , Full Load	50mS/250mS

TYPICAL WAVES AND CURVES

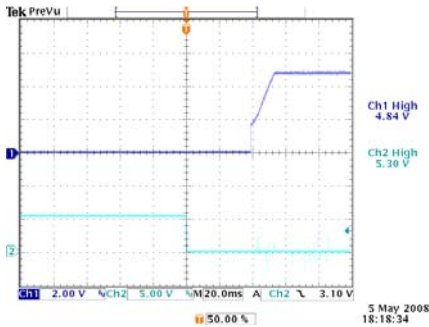

Start-up waveform of UH48050abcd-A0XXX
(V_{IN} : 50V, Load: 100A)

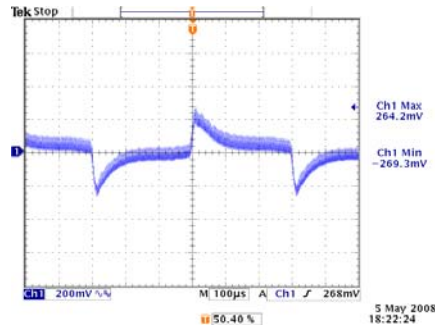

Transient response of UH48050abcd-A0XXX
(V_{IN} : 50V, Load: 70.0A/50.0A@2.5A/µS)

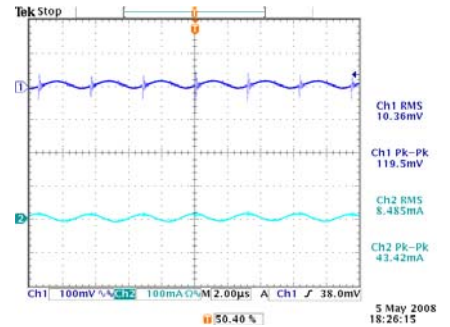

Input/Output ripples of UH48050abcd-A0XXX
(V_{IN} : 50V, Load: 100A, L_{IN} =10µH)

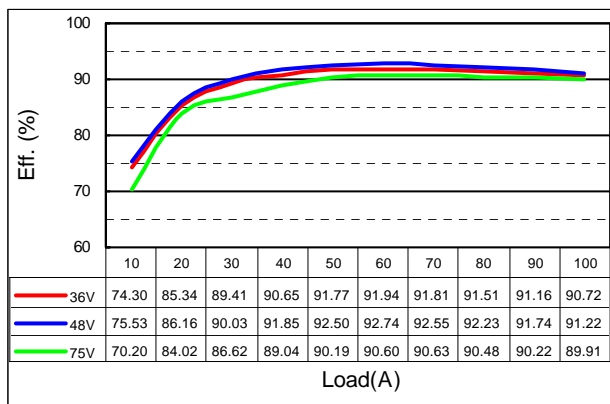

Efficiency plot of UH48050abcB-A0XXX

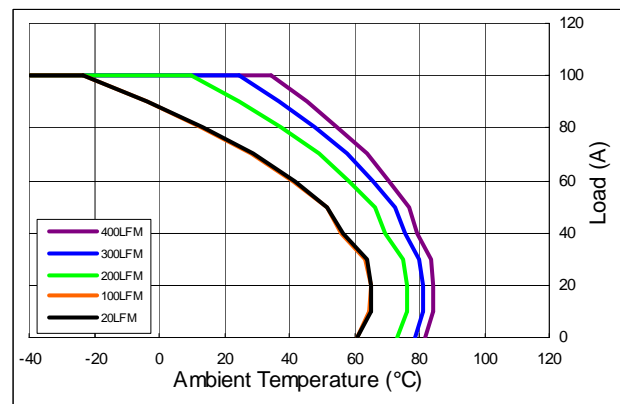

Derating curves of UH48050abcB-A0XXX for $T_C = 110^\circ\text{C}$

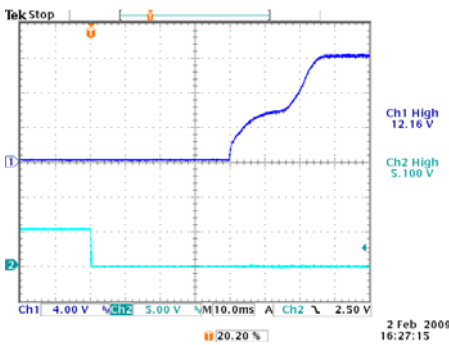

Start-up waveform of UH48120abcd-50XXX
(V_{IN} : 48V, Load: 50A)

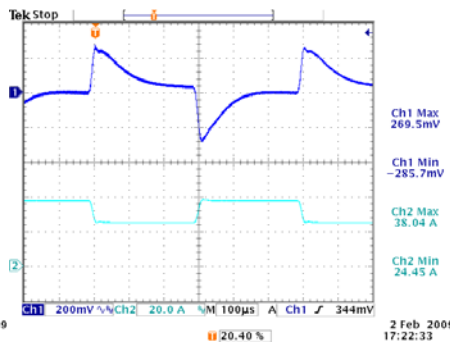

Transient response of UH48120abcd-50XXX
(V_{IN} : 48V, Load: 38.0A/25.0A@2.5A/µS)

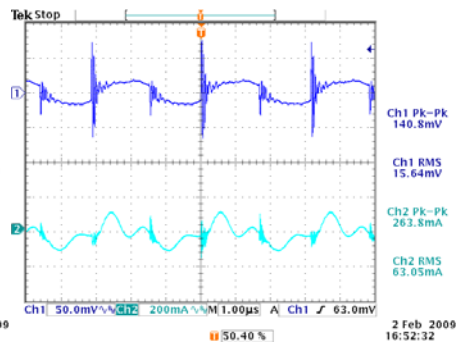

Input/Output ripples of UH48120abcd-50XXX
(V_{IN} : 48V, Load: 50A, L_{IN} =10µH)

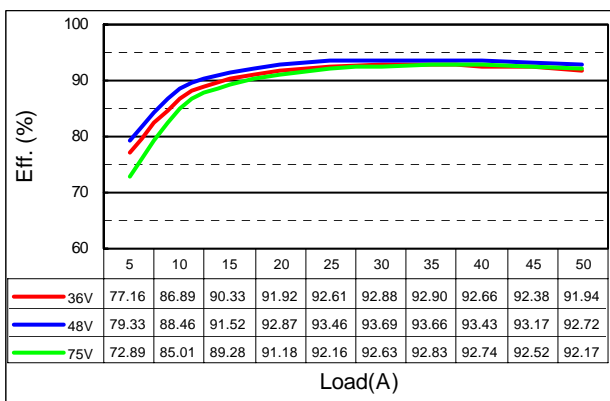

Efficiency plot of UH48120abcB-50XXX

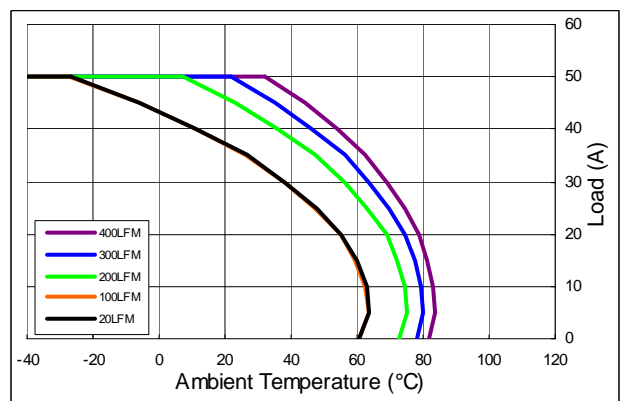

Derating curves of UH48120abcB-50XXX for $T_C = 110^\circ\text{C}$

OPEN FRAME PACKAGE

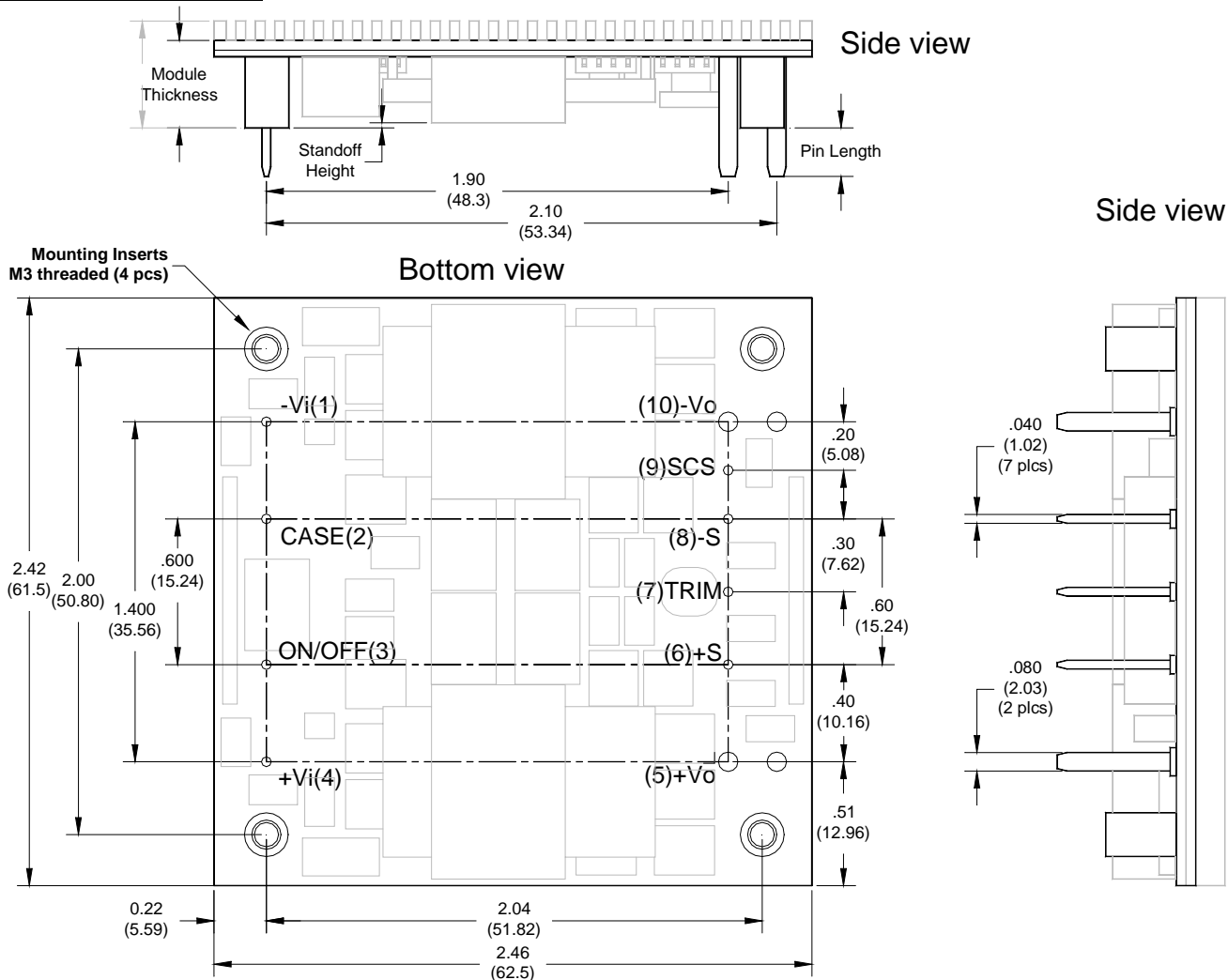

Dimensions and Pin Connections

Designation	Function Description	Pin #
-Vi	Negative input	1
CASE	Connected to base plate	2
ON/OFF	Remote control. To turn-on and turn-off output.	3
+Vi	Positive input	4
+Vo	Positive output	5
+S	Positive remote sense	6
TRIM	Output voltage adjust	7
-S	Negative remote sense	8
SCS	Secondary current share bus	9
-Vo	Negative output	10

Dimensions: inches (mm)

Tolerances: .xx±0.02 (.x±0.5)
.xxx±0.01 (.x±0.25)

Mass: 87g / 1.0mm metal plate
94g / 3.0 mm metal plate

Base plate: Aluminum alloy with anode oxide

Mounting inserts: Stainless steel

Maximum torque: 3.9 in-lb (0.44Nm)

Pin material: Copper alloy or Brass

Pin plating: Golden over Nickel

REFERENCED EMC CIRCUIT

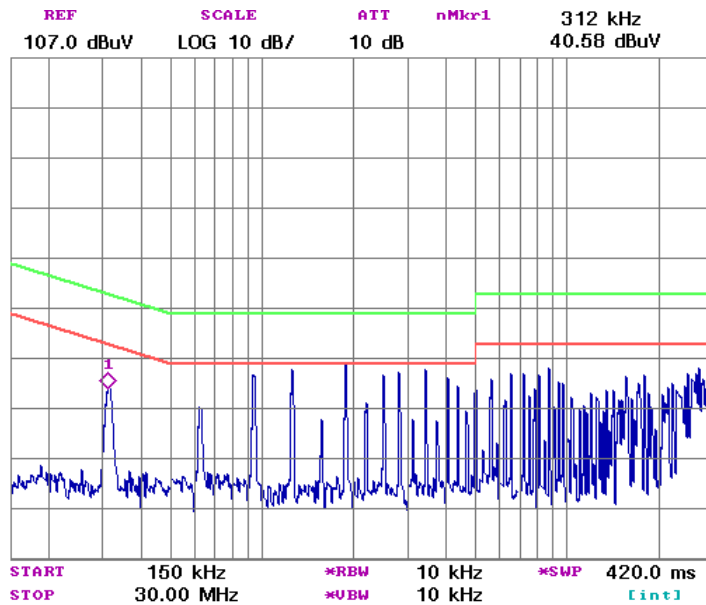

Referenced EMC Performance

The tested result shown in left-hand side is obtained by loading the power module with a resistive load only. It can be used as a design reference for customer system. However! The performance of customer's system depends on the whole system design. It should be noted that modifications on the circuit parameters and fine adjustment of the final layout affect the final EMC performance greatly.

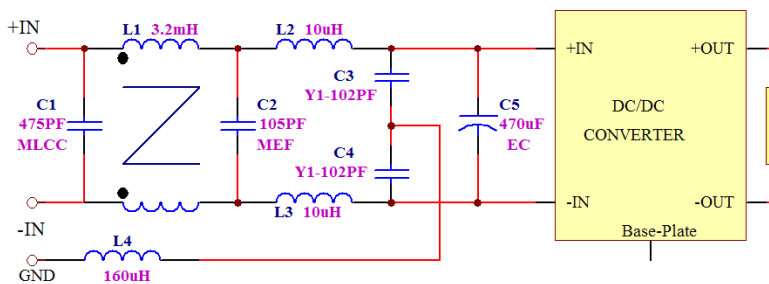

Bandwidth of EMC Components

No components are ideal for infinite frequency range. The bandwidth of EMC components should be taking into consideration when designing an EMC filter circuit. To connect ceramic capacitor with electricity capacitor in parallel and connect low inductance inductor with big one could get a better bandwidth.

Measured conductive level of UH48120abcd-S50XXX and referenced filter circuit

NOTE:

1. It is recommended that the input should be protected by fuses or other protection devices.
2. All specifications are typical at nominal input, full load and 25°C unless otherwise noted.
3. Specifications are subject to change without notice.
4. Printed or downloaded datasheets are not subject to Glary document control.
5. Product labels shown, including safety agency certificates, may vary based on the date of manufacture.
6. Information provided in this documentation is for ordering purposes only.
7. This product is not designed for use in critical life support systems, equipment used in hazardous environments, nuclear control systems or other such applications, which necessitate specific safety and regulatory standards other than the ones listed in this datasheet.

IMPORTANT

- ✘ General specifications and the performances are related to standard series only, no special customer specification display here except requested items.
- ✘ In order to secure effective usage of converter and the validity of Glary's service and warranty coverage, please refer to the application notes for general usage. For needs of usage beyond the application notes, please contact to Glary headquarter or our regional sales representative office for help.

Efficiency >92% 145W/in³ Full Metal Package OCP 2.96Mhrs MTBF

Remote ON/OFF INPUT 2:1 OVP OTP



The **Enclosed UQ** series provides up to 300W/60A outputs with industry standard quarter brick pin assignment. The high thermal conductivity silicone potted six-sides metal package is designed for applications under extreme environmental conditions. The efficient SR stage is combined with patented "Buck Reset" topology for reduce power loss to achieve 145W/in³ power density. The multi-layer single side circuit board design plus the metal-plate technology would enhance the thermal performance and improve its reliability. Modules are designed for Telecom, Servers, Networking equipments and other applications that use a 24V or 48V input bus.

PART NUMBER SYSTEM

UQ	48	050	a	b	c	d	-	25	XX	X
Series Name	Input Voltage	Output Voltage	Enable Logic	Pin Dimension	Standoff Height	Base-Plate		Output Current	Suffix	Version
UQ	48=36V~75V 24=18V~36V	Unit: 0.1V Increments 120=12V 050=5V	P: Positive N: Negative	0 : 0.12" 1 : 0.16" 2 : 0.20" 3 : 0.24"	0 : 0.02"	U : 3.0mm Metal Plate V : 5.0mm Metal Plate	-	00~60 : For output current rating	For marketing purpose only	

MODEL LIST (Contact to factory for special input / output)

Part Number *	Maximum Input		Maximum Output		Efficiency	Part Number *	Maximum Input		Maximum Output		Efficiency
UQ48120abcd-25XXX	36V~75V	326W	12.0V/25A	300W	92%	UQ24120abcd-25XXX	18V~36V	330W	12.0V/25A	300W	92%
UQ48070abcd-40XXX	36V~75V	308W	7.0V/40A	280W	91%	UQ24070abcd-40XXX	18V~36V	308W	7.0V/40A	280W	91%
UQ48050abcd-60XXX	36V~75V	330W	5.0V/60A	300W	91%	UQ24050abcd-60XXX	18V~36V	330W	5.0V/60A	300W	90%
UQ48033abcd-60XXX	36V~75V	221W	3.3V/60A	198W	90%	UQ24033abcd-60XXX	18V~36V	221W	3.3V/60A	198W	90%

REFERENCED THERMAL IMAGES

To be updated in next version	To be updated in next version
-------------------------------	-------------------------------

SPECIFICATIONS

Absolute Maximum Ratings		
Temperature	Operation Storage	-40°C to +110°C -55°C to +125°C
Input Voltage Range	Operation: 24V Models 48V Models Transient (100mS): 24V Models 48V Models	-0.5V to +40Vdc -0.5V to +80Vdc 50V Maximum 100V Maximum
Isolation Voltage	Input to Output Input to Case Output to Case	2.0KV Minimum 1.0KV Minimum 1.0KV Minimum
Remote Control		-0.5V to +12Vdc

General Parameters		
Conversion Efficiency	Typical	See table
Switching Frequency	Typical	330KHz
MTBF	Bellcore TR-332 issue 6	2.96x10 ⁶ hrs @GB/25°C (UQ48050abcd-60XXX)
OTP	Internal	110°C(Tc) ±5°C
Weight	3.0mm metal plate 5.0mm metal plate	105g 119g

Control Functions		
Remote Control	Logic High Logic Low	+3.0V to +6.5V 0V to +1.0V
Input Current of Remote Control Pin		-0.5mA ~ +1.5mA

Input		
Operation Voltage Range	24V Models 48V Models	+18V to +36Vdc +36V to +75Vdc
Reflected Ripple Current	L _{EXT} = 10uH	30mA rms/100mAp-p
Power ON Voltage Ranges	24V Models 48V Models	+17.0V to +18.0Vdc +34.0V to +36.0Vdc
Power OFF Voltage Ranges	24V Models 48V Models	+15.6V to +16.6Vdc +31.2V to +33.2Vdc
Off State Input Current	V _{NOM}	6mA Max
Latch-State Input Current	V _{NOM}	8mA Max
Input Capacitance	24V Models 48V Models	33.0uF Max 12.0uF Max

Output		
Voltage Accuracy	Typical	±1.0%
Line Regulation	Full Input Range	±0.3%
Load Regulation	0%~100%	±0.3%
Temperature Drift	-40°C ~100°C	±0.03%/°C
Output Tolerance Band	All Conditions	±4%
Ripple & Noise (20MHz)	Peak-Peak (RMS)	3% (1%) V _O
Over Voltage Protection	V _{NOM} , 10% Load	115~130 %V _O
Output Current Limits	V _{NOM}	108%~125%
Voltage Trim	V _{NOM} , 10% Load	±10%
Input Ripple Rejection (<1KHz)	V _{NOM} , Full Load	-50dB
Step Load (2.5A/μS)	50%~75% Load	±6%Vo/500μS
Start-Up Delay Time	V _{NOM} , Full Load	20mS/250mS

TYPICAL WAVES AND CURVES

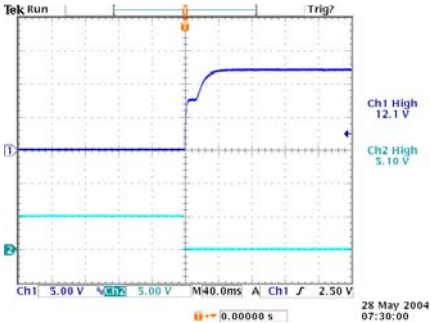

Start-up waveform of UQ48120abcd-21XXX
(V_{IN} : 50V, Load: 21A)

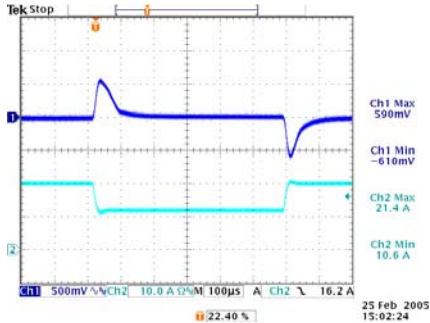

Transient response of UQ48120abcd-21XXX
(V_{IN} : 50V, Load: 21.0A/10.5A@2.5A/µs)

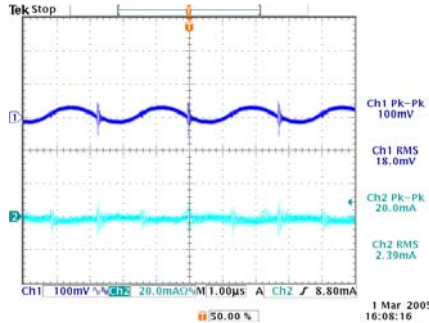

Input/Output ripples of UQ48120abcd-21XXX
(V_{IN} : 50V, Load: 21A, L_{IN} =10uH, C_{IN} =470uF)

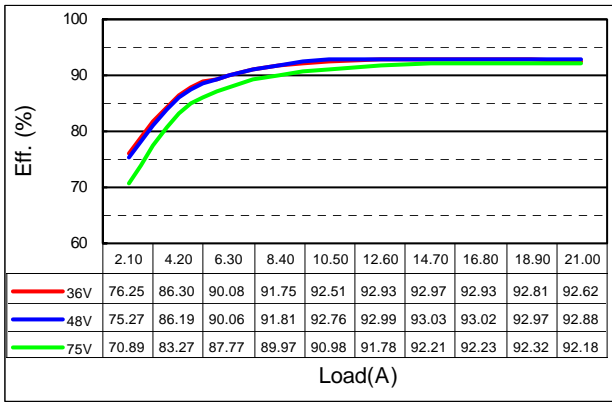

Efficiency plot of UQ48120abcB-21XXX

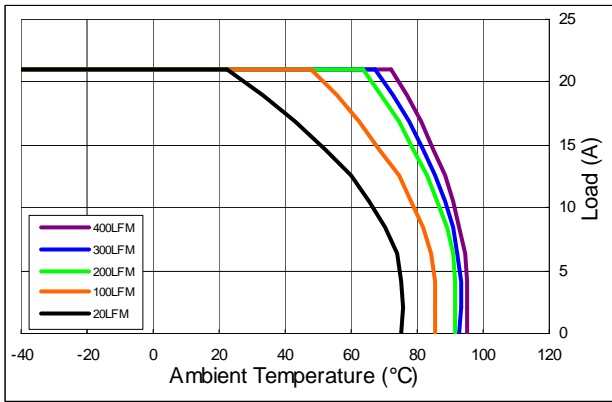

Derating curves of UQ48120abcB-21XXX for $T_C = 110^\circ C$

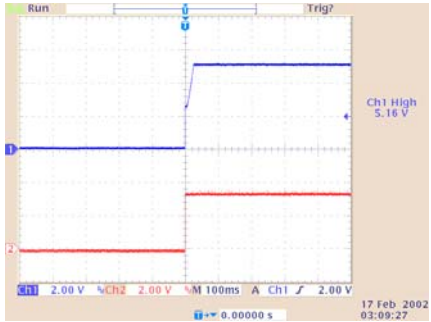

Start-up waveform of UQ48050abcd-50XXX
(V_{IN} : 50V, Load: 50A)

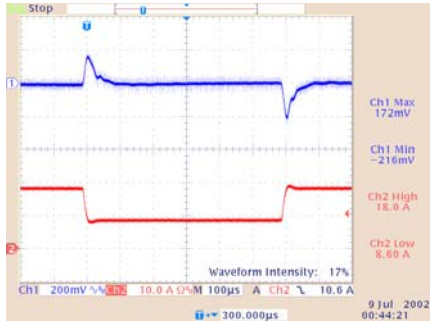

Transient response of UQ48050abcd-50XXX
(V_{IN} : 50V, Load: 18.0A/8.5A@2.5A/µs)

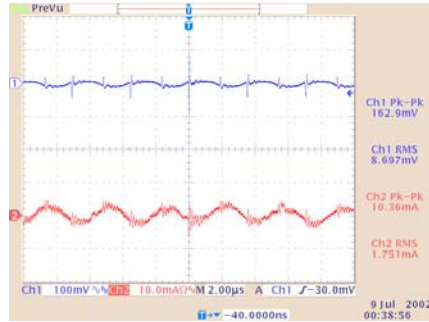

Input/Output ripples of UQ48050abcd-50XXX
(V_{IN} : 50V, Load: 50A, L_{IN} =10uH)

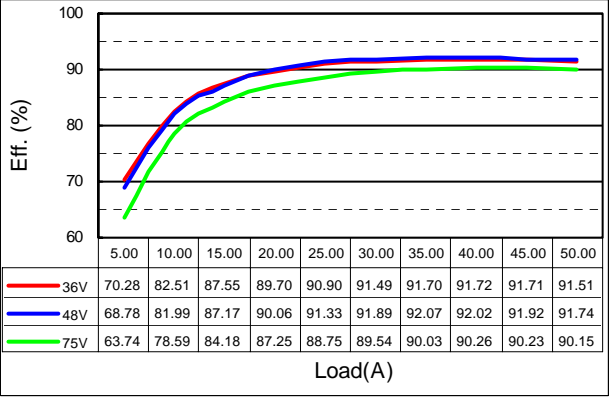

Efficiency plot of UQ48050abcB-50XXX

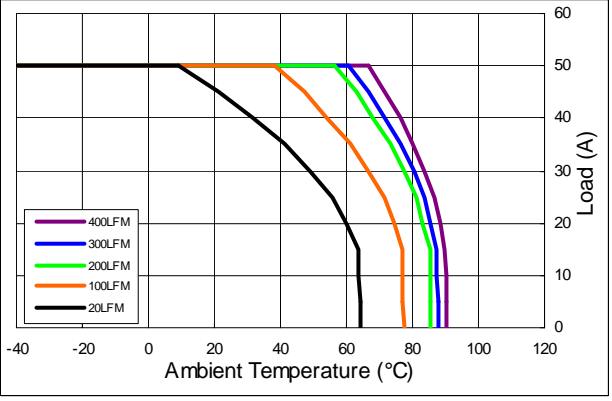

Derating curves of UQ48050abcB-50XXX for $T_C = 110^\circ C$

Enclosed UQ Series

METAL ENCLOSED PACKAGE

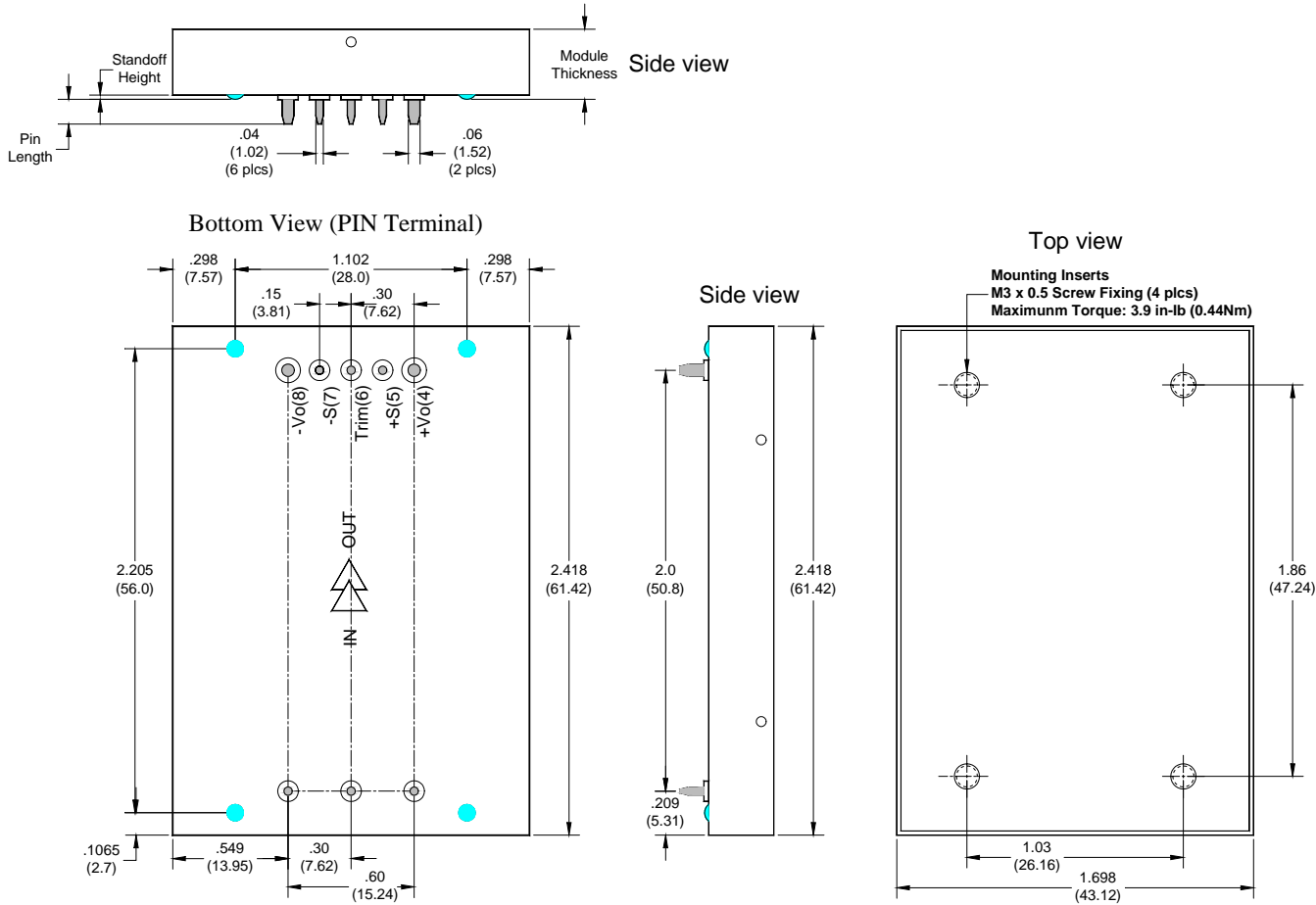

Dimensions and Pin Connections

Designation	Function Description	Pin #
-IN	Negative input	1
PC	Remote control. To turn-on and turn-off output.	2
+IN	Positive input	3
+Vo	Positive output	4
+S	Positive remote sense	5
TRIM	Output voltage adjust	6
-S	Negative remote sense	7
-Vo	Negative output	8

Dimensions: inches (mm)
Tolerances: .xx±0.02 (.x±0.5)
 .xxx±0.01 (.x±0.25)
Weight: 105g / 3.0mm metal plate
 119g / 5.0mm metal plate
Base plate: Aluminum alloy with anode oxide
Mounting inserts: Stainless steel
Maximum torque: 3.9 in-lb (0.44Nm)
Pin material: Copper alloy or Brass
Pin plating: Golden over Nickel

REFERENCED EMC CIRCUIT

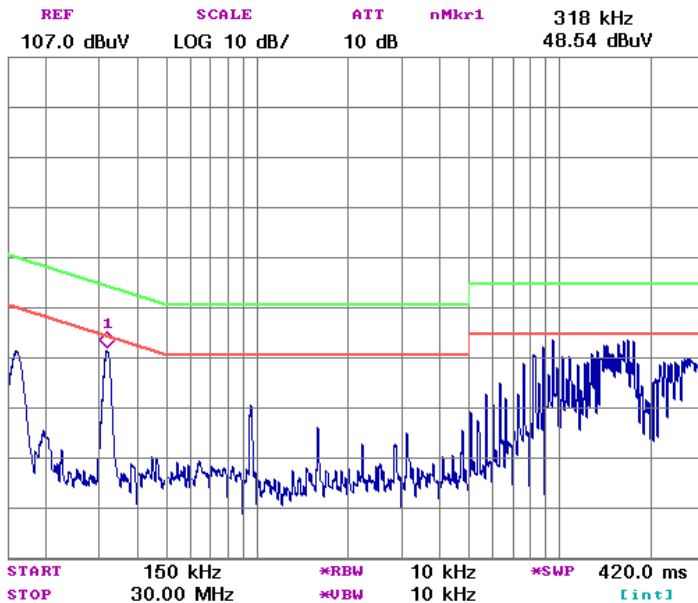

Referenced EMC Performance

The tested result shown in left-hand side is obtained by loading the power module with a resistive load only. It can be used as a design reference for customer system. However! The performance of customer's system depends on the whole system design. It should be noted that modifications on the circuit parameters and fine adjustment of the final layout affect the final EMC performance greatly.

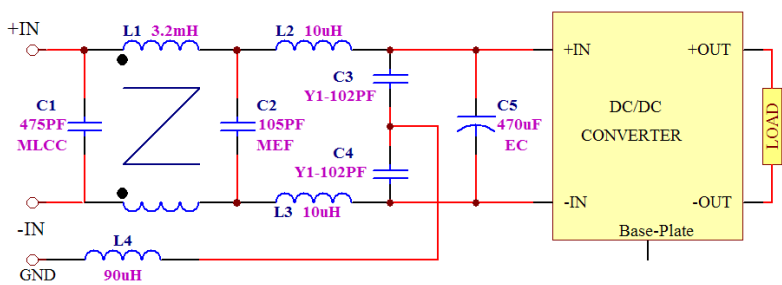

Measured conductive level of UQ48120abcd-21XXX and referenced filter circuit

Bandwidth of EMC Components

No components are ideal for infinite frequency range. The bandwidth of EMC components should be taking into consideration when designing an EMC filter circuit. To connect ceramic capacitor with electricity capacitor in parallel and connect low inductance inductor with big one could get a better bandwidth.

NOTE:

1. It is recommended that the input should be protected by fuses or other protection devices.
2. All specifications are typical at nominal input, full load and 25°C unless otherwise noted.
3. Specifications are subject to change without notice.
4. Printed or downloaded datasheets are not subject to Glary document control.
5. Product labels shown, including safety agency certificates, may vary based on the date of manufacture.
6. Information provided in this documentation is for ordering purposes only.
7. This product is not designed for use in critical life support systems, equipment used in hazardous environments, nuclear control systems or other such applications, which necessitate specific safety and regulatory standards other than the ones listed in this datasheet.

IMPORTANT

- ✳ General specifications and the performances are related to standard series only, no special customer specification display here except requested items.
- ✳ In order to secure effective usage of converter and the validity of Glary's service and warranty coverage, please refer to the application notes for general usage. For needs of usage beyond the application notes, please contact to Glary headquarter or our regional sales representative office for help.

Efficiency >92% 235W/in³ Open Frame Package OCP 2.96Mhrs MTBF

Remote ON/OFF INPUT 2:1 OVP OTP



The **UQ** series provides up to 300W/60A outputs with industry standard quarter brick package. The efficient SR stage is combined with patented "Buck Reset" topology that would reduce power loss to achieve 235W/in³ power density. The multi-layer single side circuit board design plus the patented Sink-Plate technology would enhance the thermal performance and improve its reliability. Modules are designed for Telecom, Servers, Networking equipments and other applications that use a 24V or 48V input bus.

PART NUMBER SYSTEM

UQ	48	120	a	b	c	d	-	25	XX	X
Series Name	Input Voltage	Output Voltage	Enable Logic	Pin Dimension	Standoff Height	Base-Plate		Output Current	Suffix	Version
UQ	48=36V~75V 24=18V~36V	Unit: 0.1V Increments 120=12V 050=5V	P: Positive N: Negative	0 : 0.12" 1 : 0.16" 2 : 0.20" 3 : 0.24"	0 : 0.02" 1 : 0.08" 2 : 0.16"	M : 1.0mm Metal Plate S : 3.0mm Metal Plate Z : 5.0mm Metal Plate A : 3.0mm Sink-Plate B : 5.0mm Sink-Plate		00~60 : For output current rating		For marketing purpose only

MODEL LIST (Contact to factory for special input / output)

Part Number *	Maximum Input	Maximum Output	Efficiency	Part Number *	Maximum Input	Maximum Output	Efficiency
UQ48120abcd-25XXX	36V~75V 326W	12.0V/25A 300W	92%	UQ24120abcd-25XXX	18V~36V 330W	12.0V/25A 300W	91%
UQ48070abcd-40XXX	36V~75V 308W	7.0V/40A 280W	91%	UQ24070abcd-40XXX	18V~36V 308W	7.0V/40A 280W	91%
UQ48050abcd-60XXX	36V~75V 330W	5.0V/60A 300W	91%	UQ24050abcd-60XXX	18V~36V 330W	5.0V/60A 300W	90%
UQ48033abcd-60XXX	36V~75V 221W	3.3V/60A 198W	90%	UQ24033abcd-60XXX	18V~36V 221W	3.3V/60A 198W	90%

REFERENCED THERMAL IMAGES

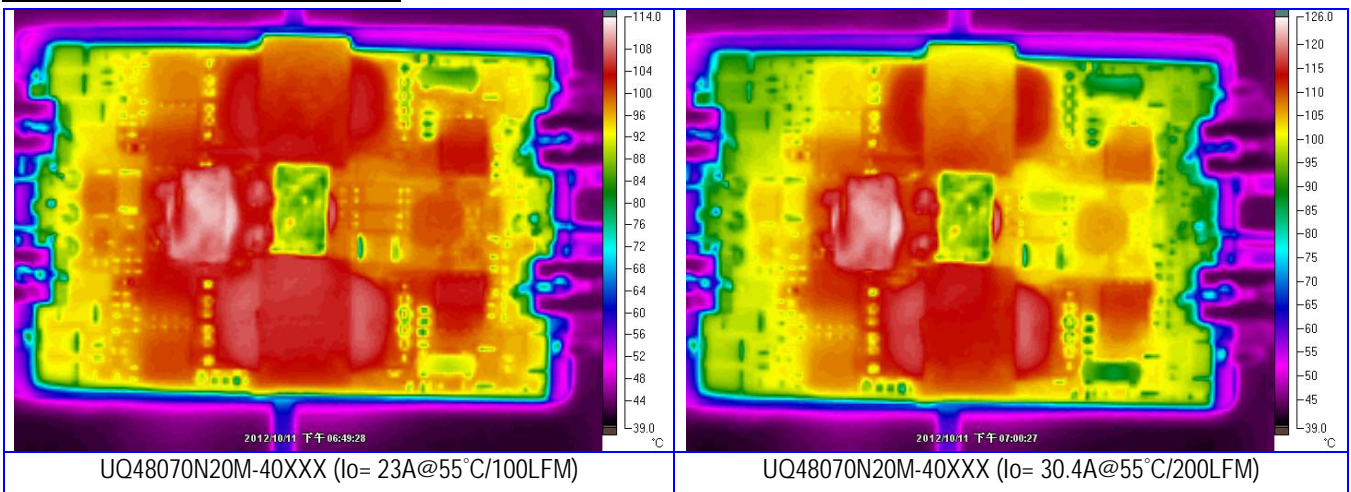

SPECIFICATIONS

Absolute Maximum Ratings		
Temperature	Operation Storage	-40°C to +110°C -55°C to +125°C
Input Voltage Range	Operation: 24V Models 48V Models Transient (100mS): 24V Models 48V Models	-0.5V to +40Vdc -0.5V to +80Vdc 50V Maximum 100V Maximum
Isolation Voltage	Input to Output Input to Case Output to Case	2.0KV Minimum 1.0KV Minimum 1.0KV Minimum
Remote Control		-0.5V to +12Vdc

General Parameters		
Conversion Efficiency	Typical	See table
Switching Frequency	Typical	330KHz
MTBF	Bellcore TR-332 issue 6	2.96x10 ⁶ hrs @GB/25°C (UQ48050abcd-60XXX)
OTP	Internal	110°C(Tc) ±5°C
Weight	1.0mm metal plate 3.0mm metal plate	43g 56g

Control Functions		
Remote Control	Logic High Logic Low	+3.0V to +6.5V 0V to +1.0V
Input Current of Remote Control Pin		-0.5mA ~ +1.5mA

Input		
Operation Voltage Range	24V Models 48V Models	+18V to +36Vdc +36V to +75Vdc
Reflected Ripple Current	L _{EXT} = 10uH	30mA rms/100mAp-p
Power ON Voltage Ranges	24V Models 48V Models	+17.0V to +18.0Vdc +34.0V to +36.0Vdc
Power OFF Voltage Ranges	24V Models 48V Models	+15.6V to +16.6Vdc +31.2V to +33.2Vdc
Off State Input Current	V _{NOM}	6mA Max
Latch-State Input Current	V _{NOM}	8mA Max
Input Capacitance	24V Models 48V Models	33.0uF Max 12.0uF Max

Output		
Voltage Accuracy	Typical	±1.0%
Line Regulation	Full Input Range	±0.3%
Load Regulation	0%~100%	±0.3%
Temperature Drift	-40°C ~100°C	±0.03%/°C
Output Tolerance Band	All Conditions	±4%
Ripple & Noise (20MHz)	Peak-Peak (RMS)	3% (1%) V _O
Over Voltage Protection	V _{NOM} , 10% Load	115~130 %V _O
Output Current Limits	V _{NOM}	108%~125%
Voltage Trim	V _{NOM} , 10% Load	±10%
Input Ripple Rejection (<1KHz)	V _{NOM} , Full Load	-50dB
Step Load (2.5A/μS)	50%~75% Load	±6%Vo/500μS
Start-Up Delay Time	V _{NOM} , Full Load	20mS/250mS

TYPICAL WAVES AND CURVES

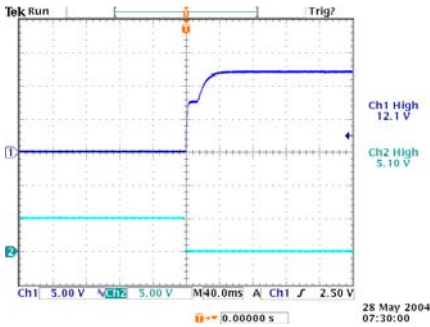

Start-up waveform of UQ48120abcd-21XXX
(V_{IN} : 50V, Load: 21A)

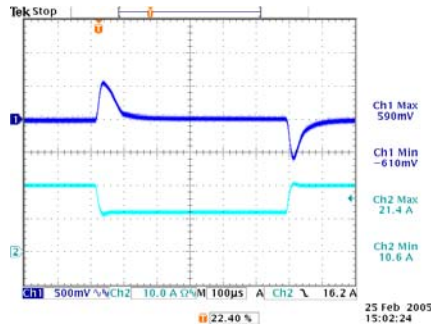

Transient response of UQ48120abcd-21XXX
(V_{IN} : 50V, Load: 20A/10A@2.5A/µs)

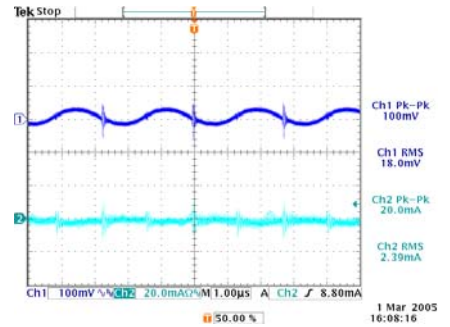

Input/Output ripples of UQ48120abcd-21XXX
(V_{IN} : 50V, Load: 21A, L_{IN} =10µH)

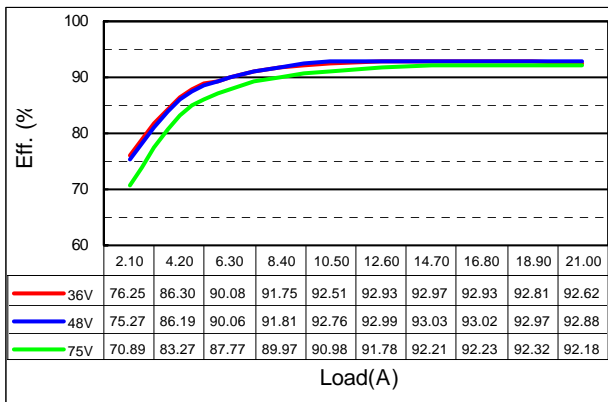

Efficiency plot of UQ48120abcM-21XXX

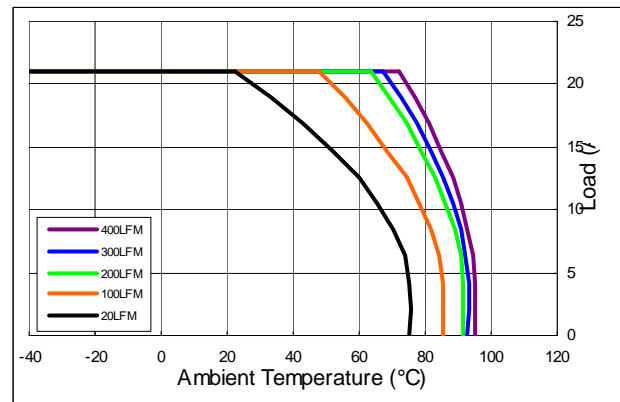

Derating curves of UQ48120abcM-21XXX for $T_C = 110^\circ\text{C}$

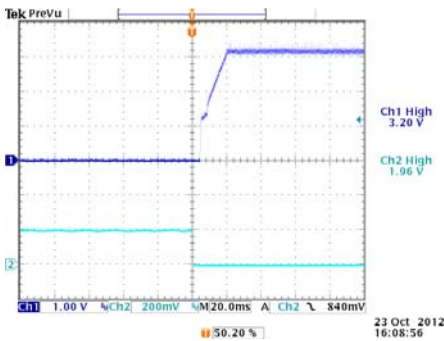

Start-up waveform of UQ48033abcd-60XXX
(V_{IN} : 48V, Load: 60A)

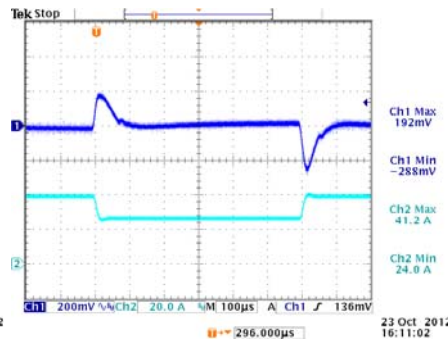

Transient response of UQ48033abcd-60XXX
(V_{IN} : 48V, Load: 41.0A/24.0A@2.5A/µs)

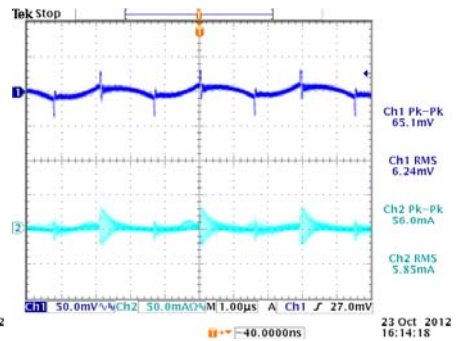

Input/Output ripples of UQ48033abcd-60XXX
(V_{IN} : 48V, Load: 60A, L_{IN} =10µH)

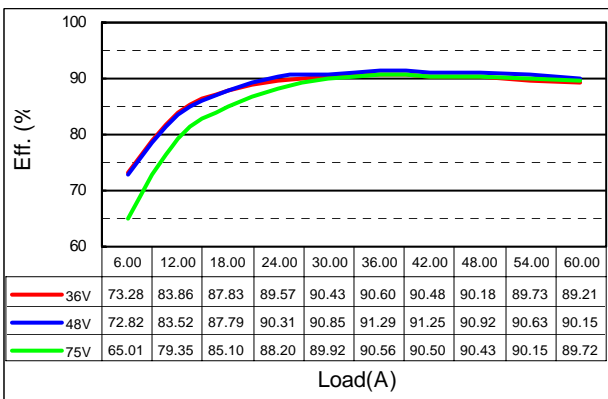

Efficiency plot of UQ48033abcM-60XXX

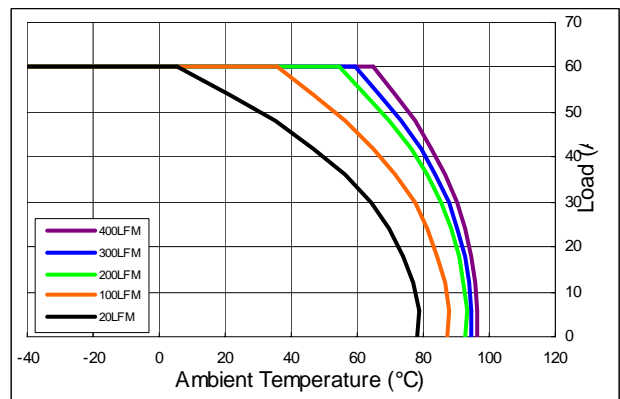

Derating curves of UQ48033abcM-60XXX for $T_C = 110^\circ\text{C}$

OPEN FRAME PACKAGE

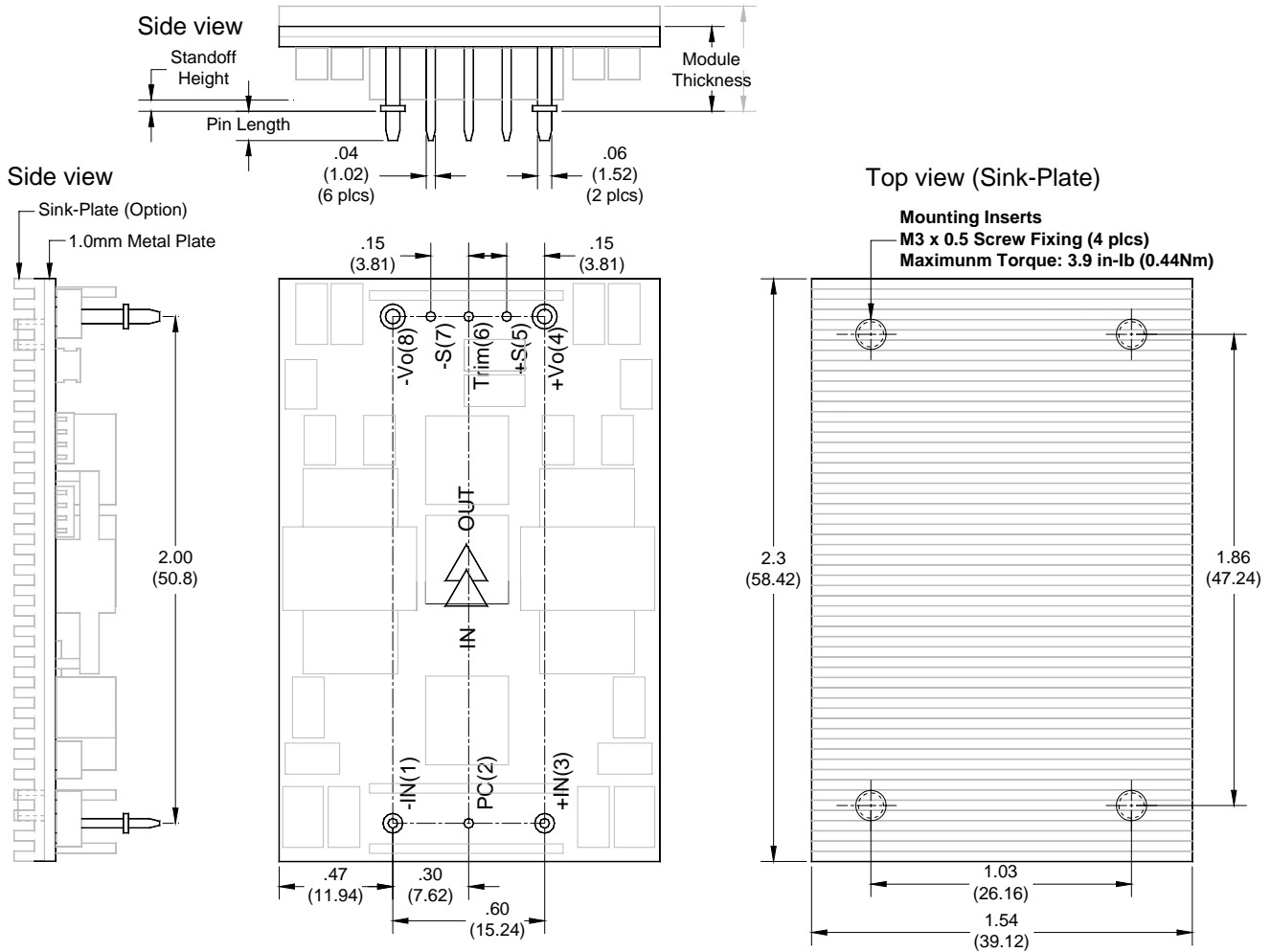

Dimensions and Pin Connections

Designation	Function Description	Pin #
-IN	Negative input	1
PC	Remote control. To turn-on and turn-off output.	2
+IN	Positive input	3
+Vo	Positive output	4
+S	Positive remote sense	5
TRIM	Output voltage adjust	6
-S	Negative remote sense	7
-Vo	Negative output	8

Dimensions: inches (mm)

Tolerances: .xx±0.02 (.x±0.5)
.xxx±0.01 (.x±0.25)

Weight: 43g / 1.0mm metal plate
56g / 3.0mm metal plate

Base plate: Aluminum alloy with anode oxide

Mounting inserts: Stainless steel
Maximum torque: 3.9 in-lb (0.44Nm)

Pin material: Copper alloy or Brass

Pin plating: Golden over Nickel

REFERENCED EMC CIRCUIT

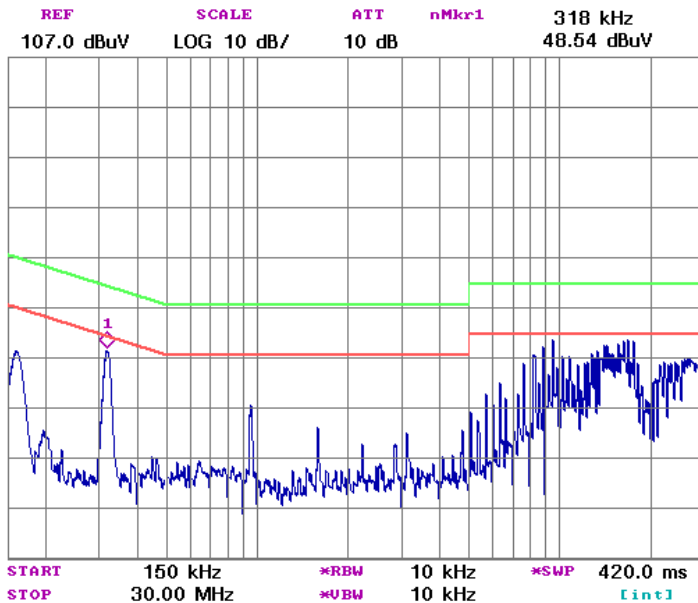

Referenced EMC Performance

The tested result shown in left-hand side is obtained by loading the power module with a resistive load only. It can be used as a design reference for customer system. However! The performance of customer's system depends on the whole system design. It should be noted that modifications on the circuit parameters and fine adjustment of the final layout affect the final EMC performance greatly.

Bandwidth of EMC Components

No components are ideal for infinite frequency range. The bandwidth of EMC components should be taking into consideration when designing an EMC filter circuit. To connect ceramic capacitor with electricity capacitor in parallel and connect low inductance inductor with big one could get a better bandwidth.

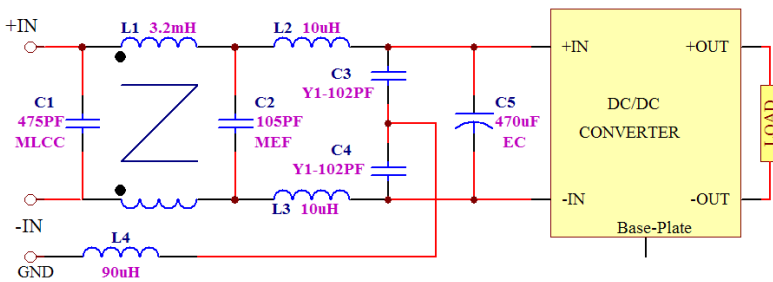

Measured conductive level of UQ48070abcd-35XXX and referenced filter circuit

NOTE:

1. It is recommended that the input should be protected by fuses or other protection devices.
2. All specifications are typical at nominal input, full load and 25°C unless otherwise noted.
3. Specifications are subject to change without notice.
4. Printed or downloaded datasheets are not subject to Glary document control.
5. Product labels shown, including safety agency certificates, may vary based on the date of manufacture.
6. Information provided in this documentation is for ordering purposes only.
7. This product is not designed for use in critical life support systems, equipment used in hazardous environments, nuclear control systems or other such applications, which necessitate specific safety and regulatory standards other than the ones listed in this datasheet.

IMPORTANT

- ✳ General specifications and the performances are related to standard series only, no special customer specification display here except requested items.
- ✳ In order to secure effective usage of converter and the validity of Glary's service and warranty coverage, please refer to the application notes for general usage. For needs of usage beyond the application notes, please contact to Glary headquarter or our regional sales representative office for help.

General Operating Information

General

Absolute Maximum Ratings

Some ratings, shown in ABSOLUTE MAXIMUM RATINGS, are the absolute maximum ratings referring to no destruction or design limits, normally tested with one parameter while exceeding the limits of absolute maximum ratings or electrical characteristics.

The stress exceeding the absolute maximum ratings may cause permanent damage, function and performance degraded. As far as design margin and enhancing system reliability are concerned, it is recommended that Glary DC/DC converters operate below 90°C of case temperature. The over temperature protection set point is 5°C ~10°C higher of maximum operation base plate temperature.

Safety

Standards

All product series of Glary DC/DC converters are designed to comply with UL in accordance with EN60950 safety of information technology equipment including electrical business equipment. These DC/DC converters meet the U.S. and Canadian Standard for safety of information technology equipment, including electrical business equipment applicable requirement in CSA/UL60950. Most product series of Glary DC/DC converters are recognized by UL, CSA and TUV.

Isolation

Operational or Basic insulation is performed in accordance with EN60950. All product series, built in DC-to-DC converter power supplies, should be installed in end-use equipment for printed wiring board or chassis mountable, and intend to be supplied by isolated secondary circuit. Consideration should be given to measure the case temperature to comply with maximum case temperature during module operation.

When the supply to DC/DC converter meets all requirements for SELV, the output is considered to remain SELV limit. For supply voltage from 60V to 75V DC, reinforced insulation must be provided in the 75V power source that isolates the input from the mains. Single fault testing in the 75V supply circuit will be performed in combining with the DC/DC converter to demonstrate that the output meets the requirement for SELV. One pole of the input and the other one of the output are going to be grounded or both circuits are to be kept floated.

The isolation, withstanding 1500V or 2000 DC between input and output depending on different

series, 1000V DC between input/output and case with all series, is verified in an electrical strength test.

Flammability

The flammability ratings of plastic parts and PCBs meet UL-94V-0.

Fusing

A fuse should be used at the input of each converter to isolate the failed one from others, keeping the system continue to operate and prevent the damage of power distribution wiring from over heating. A fast blow fuse should be used with 10A~20A rating or less, it is recommended using a fuse with the lowest current rating.

Input Side

Input (+IN, -IN)

Voltage Range

The input voltage range of 36V~75V meets the requirement of European Telecom Standard ETS 300 132-2 for normal input voltage range in -48V (-40.5V~ -57.0V) and -60V (-50.0V~ -72.0V) DC power systems. The absolute maximum continuous input voltage is 75V DC and withstands 100V DC/100ms maximum transient voltage. The range 18V~36V for 24V version is also available.

Input Capacitance

The input characteristic of a DC/DC converter may be referred as a negative-incremental impedance element in its input voltage range. Sometimes, oscillation will be occurred when high impedance power source is applied to supply power to a DC/DC converter. An external input capacitor is recommended to reduce the characteristic impedance and eliminate the oscillation between the DC/DC converter and the source.

Generally speaking, a 220uF~470uF capacitor across the input of all DC/DC converter product series will help to insure stability.

ON/OFF Control (ON/OFF or PC)

These product series of DC/DC converter has the remote on/off control pin can be connected to an external ON/OFF control signal for turning ON and OFF. The control signal of ON/OFF pin is referred to the negative power input pin and two control logic options are available.

Negative Logic

ON: Short to negative power input pin or apply voltage of logic low.

OFF: Opening circuit or apply the voltage of logic high.

Positive Logic

ON: Opening circuit or apply the voltage of logic high.
OFF: Short to negative power input pin or apply voltage of logic low.

A mechanical switch or an open collector NPN transistor (open drain N channel FET) can be used to drive the ON/OFF pin. The device must be capable of sinking 1mA minimum at a logic low voltage 1.0V and withstands 12V DC minimum.

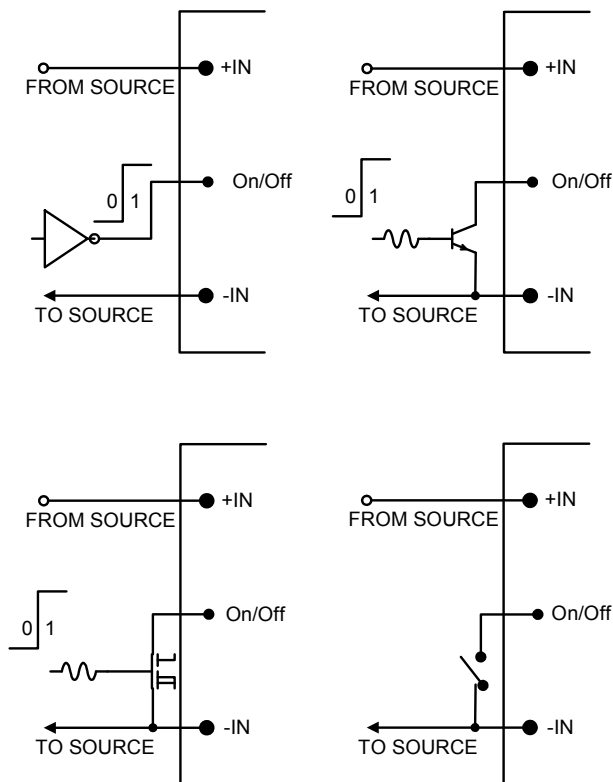

Output Side

Output (+OUT, -OUT)

Ripple & Noise

The ripple of DC/DC converters is measured as peak-to-peak voltage from 0 to 20MHz including the noise and the fundamental ripple. The ripple and noise can be reduced significantly by paralleling a de-coupling capacitor to the output terminal.

Over Current Protection (OCP)

These DC/DC converters provide OCP function to withstand continuous overload or short circuit condition in the output. The converter will recover to normal operation after the overload is removed. The OCP set point of these DC/DC converters is 108%~125% of rated output current.

Output Over Voltage Protection (OVP)

These DC/DC converters provide OVP lockout function to prevent the damage of load from over

voltage condition on the output. The converter will restart after recycling the input power or control signal of primary control pin. The OVP set point of these DC/DC converters is 115%~130% of rated output voltage.

Remote Sense (+S, -S)

These DC/DC converters have the remote sense pins that can be used to compensate voltage drop due to the resistance in the distribution system. It allows the output voltage can be regulated at the load or a selected point. It should be noted that the sense line must be located close to a ground trace or a ground panel to reduce noise, a twisted wire pair is recommended for discrete wiring. The sense pin will compensate 0.5V maximum of voltage drop between the sensed voltage and the voltage of output pins.

Output Voltage Adjust (TRIM or SC)

These DC/DC converters have the secondary control pin used to adjust output voltage beyond or below nominal output voltage. It should be noted that trim up to be above OVP set point may cause a converter to enter the over voltage protection state. The TRIM pin is noise sensitivity and the external resistors should be located within 1cm of the converter. If not using the trim feature, leave the TRIM pin open.

TRIM UP: connect a trim resistor (R_U) between TRIM pin and +S pin.

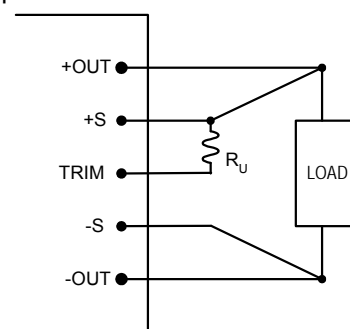

TRIM DOWN: connect a trim resistor (R_D) between SC pin and -S pin.

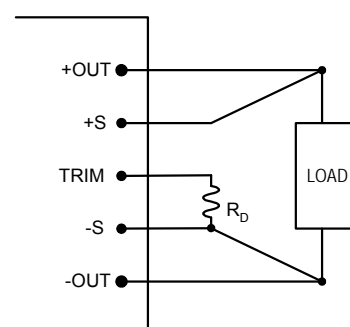

Output Capacitance

The extra output capacitance is required to improve the voltage regulation when powering a load with significant dynamic current requirement. Putting a low ESR capacitor to the load as close as possible to handle the short duration high frequency component of dynamic load current and put the higher value of electrolytic capacitor to progress the mid-frequency component. The capacitance, resistance and inductance of distribution system are used as feedback components that would in affecting stability and dynamic response performance of power converter.

In generally, 47uF~68uF/A of output current can be used for 3.3V output power module without additional analysis. For example, a 35A DC/DC converter, the de-coupling capacitor up to 4700uF can be used on the premise of not affecting the stability. Capacitor of a higher value, as much capacitance as possible, is however not encouraged as it may result in stability risks to the converters. Since the stored energy of the capacitor is proportional to V^2 , which result in the de-coupling capacitor should be reduced by a factor of $(Vo/3.3)^2$ for modules with higher output voltage. Some applications may require longer hold-up time to be performed by high output capacitance anyway, and in such case, the capacitors should be at outside of the feedback loop and closing the load, which should help with insuring the stability. The absolute maximum value of output capacitance is 10,000uF; consult with Glary for high value of output capacitance.

However, the recent modern technology has been advanced enough to allow low ESR on some specific type of capacitors (such as MLCC), which features very high reliability and nearly eliminates the needs of paralleling numerous life span constrained electrolytic caps at the system end to achieve low ESR, and further allows more simplified external output filter design for the power system. Therefore, for Glary Power's full series of product lines, simply adding a MLCC of a few to a few tens of uF close to the load should be sufficient enough. Do note that an exceeded high value of external output capacitance would result in other negative impacts to the converter's feed back loop. Please as well consult with Glary Power if higher external output capacitance is needed for the system design when using the above indicated advanced series.

Quality Reliability

For example, calculated MTBF in accordance with Bellcore TR-332 issue 6, December 1997 of COE series, is 4,801,570hours (+25°C), 2,015,270hours (+50°C), or 940,807hours (+70°C) to demonstrate the reliability of our products. This represents an average failure rate of 280.265 (+25°C), 486.211 (+50°C) and 1,062.918 (+70°C) failures per million unit hours of operations. The assumptions are full load at +25°C, +50°C and +70°C case temperature under ground benign (GB) environment condition.

Warranty

Glary Power Technology warrants to the original purchaser or the end user that the products conform to this data sheet are free from material and workmanship defects for a period of two years since the date of manufacturing, when the product is used within specified condition and not opened.

Handling

Open frame converters can be damaged from poor handling, excessive mechanical shock, or from a static electric discharge. The units should be:

- Carefully handled and not subjected to mechanical stress
- Treated as an ESD sensitive component
- Stored in a static protective container which physically protects the converter
- The converters should not be stored in plastic bags, or stacked on top of one another in any way

Limitation of Liability

Glary Power Technology does not make any warranties, express or imply including any warranty of merchantability or fitness for a particular purpose (including, but not limited to use in life support applications, where malfunction of product can cause injury to a person's health or life).

General Module Thermal Considerations

General

The Glary DC/DC converter product series are designed to operate in a variety of thermal environments; however sufficient cooling should be helpful for reliable operation. General speaking, the heat is removed from module by conduction, convection and radiation to the surrounding but convection is the most important method for the normal application at sea level. Increased airflow may strongly influence the module thermal performance. Proper cooling can be verified by measuring the temperature of base plate.

The available load current with different ambient air temperature and airflow at nominal input voltage for each model is according to real test done in a wind tunnel. However the actual derating performance of each module may slightly vary compared with the derating curves given by test performed in the data sheet, the 90% of available current shown in the derating curves is the highest recommended value for reliable system design. The actual system design would in fact strongly affect the derating performance and generally result in three variable factors to affect the module derating performance described as below:

Conversion Efficiency

The heat is generated by power loss, board mount power module convert input power for output to the load always has an efficiency between 0%~100%. The synchronous rectification technology can make power module converting the required power with dramatic efficiency and dissipating fewer power compared with traditional technology. This leads to a lower temperature rise if the module thermal resistance is the same; it means higher efficiency is better for any kind of cooling conditions because the temperature is always lower and the reliability could also be better secured.

However, most data sheet shows high efficiency with full load condition and not with the real load condition for a practical system. It is better to select a power module that has highest efficiency with specified load condition. This almost leads to a solid answer that to choose a power module rated about 1.2~1.5 times of the required power would be reliable than a power module rated at double of the actual required power or even higher, because large derating always has poor efficiency and more temperature rise. Higher derating always reduces the operation life because the temperature factor has more negative effect on MTBF to further eliminate the positive effect due to the reduced electrical stress.

Roughly calculations of Glary COQ module by changing the temperature stress and electrical stress to have different results as below could be used as an example of reference of power module selection in system design stage. At 25°C, a 10% increasing of module case temperature ($T_c = 90^\circ\text{C}$ to $T_c = 96.5^\circ\text{C}$) will reduce the life to about 75% of its originally designed figure. However! Module derating from 100% to 75% will cause life improve by about 2%.

Efficiency change between different modules also has significant effect on the temperature rise to affect the derating performance. This effect can be seen more clearly especially in high temperature operation.

For example, a 200LFM/83°C of airflow is used for cooling and the maximum case temperature of power module was set as 110°C. A COQ48050N11M-10 module with 90.2% efficiency can have a 9.5A output current with 5.16W power loss. If the efficiency is 2% lower (88.2%) at 9.5A output, it may loss 6.35W of power and further ~~to~~ cause over temperature to $T_c = 114^\circ\text{C}$ or the maximum operable temperature should reduced to $T_a = 75^\circ\text{C}$.

Module Temperature

Follow the result of conversion efficiency section; some power module makers provide derating curves by increasing the maximum board temperature and semiconductor junction temperature to 125°C to have better derating performance. This method pushes converter operating at high temperature environment, which results in two effects on the thermal characteristics:

The first effect of increasing maximum allowable temperature is that it would increase the temperature rise between module and the air may cause more heat flow through module surface to air if assuming module thermal resistance is constant. Typically the thermal resistance of specified form factor is determined by the properties of air and the contacted surface area. The properties of air are fixed when the temperature and pressure are specified. The only variable is the air contacted surface area of power module, but same form factor has almost same construction and the same contacted surface area due to no big difference on the components selection and its counts, so that the thermal resistance can be at the same level.

The second effect is to reduce thermal resistance by increasing nature convection due to increased temperature rise. It has about 8% improvement for thermal resistance with nature convection by changing the maximum allowable temperature from $T_c = 110^\circ\text{C}$ to $T_c = 125^\circ\text{C}$.

Simple calculations of Glary COQ module by changing the maximum allowable temperature from $T_c = 110^\circ\text{C}$ to $T_c = 125^\circ\text{C}$ would demonstrate the improvement of derating performance. By operating a COQ48050N11M-10 module under conditions of $T_a = 95^\circ\text{C}$, $T_c = 110^\circ\text{C}$ and Airflow=200LFM with 90.9% of conversion efficiency, it can deliver 5.0A output current with 2.50W power loss. If the allowable maximum temperature is $T_c = 125^\circ\text{C}$, the allowable power loss will go to 4.76W and the available current could be 9.5A. Plot-1 shows comparison of derating curves for reference.

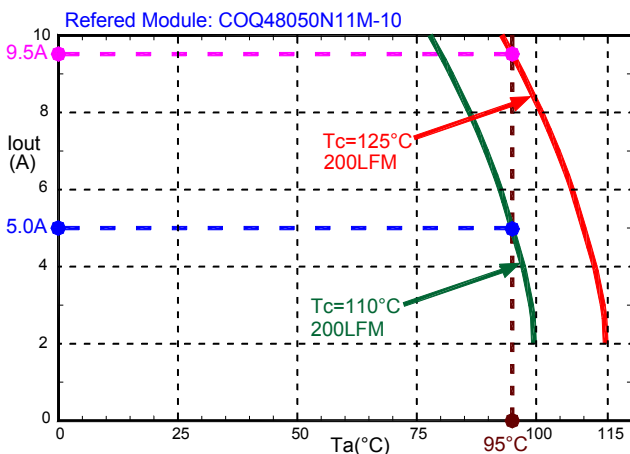

Plot-1: Derating curves for $T_c = 110^\circ\text{C}$ and $T_c = 125^\circ\text{C}$

However, even to increase the maximum allowable temperature from $T_c = 110^\circ\text{C}$ to $T_c = 125^\circ\text{C}$ would make dramatic improvement for derating performance. It pays too much for operation life, most of the circuit components used in modern power modules may reduced its life significantly due to operation under $T_c = 125^\circ\text{C}$ condition and the total effect is to reduce module life about 50%. Generally derating rule request 38°C derating for power semiconductor junction temperature and 15°C derating for $T_g = 130^\circ\text{C}$ rated PCB that means the maximum operation temperature is 112°C . All Glary products are limited under 110°C for safe operation and longer life. Set the case temperature of Glary module below 90°C during operation would be better for high reliability system.

Module Thermal Resistance

Follow the result of module temperature section; the maximum allowable temperature for operation is limited under $T_c = 110^\circ\text{C}$. Glary provide Sink-Plate technology for almost all Glary modules to reduce the module thermal resistance, and further improve thermal performance such as the derating performance and temperature deviation among the components. By choosing the Sink-Plate, the derating performance was improved dramatically and

no any compromise for the reliability and operation life because it can be used as integrated heat sink to reduce module thermal resistance when no additional cooling assemblies were attached to the module.

In general Glary modules were design for board mount application but the Sink-Plate has at least 2pcs of M3 screws to allow module to be attached to the casing, or with its heat sink to extent its thermal performance to meet the requirements of high temperature operated system. The Sink-Plate is able to reduce the deflection that it has special geometry to hold flowed gap filler due mounting force during screw mounting process and improve the thermal contact to has unified temperature map to improve the reliability again.

The simple calculations for COQ with different type of base plate are described as below, which may reflected to all Glary products and give better understanding about thermal performance and derating for specified application conditions:

For the 1.0mm metal plate:

The module thermal resistance θ_M of COQ with 1.0mm metal plate is similar to traditional power module can be listed as below:

$$\theta_M = 11.29 \text{ (Free-Air)}, 7.36 \text{ (100LFM)}, 5.65 \text{ (200LFM)}, 4.20 \text{ (300LFM)}, 3.47 \text{ (400LFM)}, 3.03 \text{ (500LFM)}$$

The thermal resistance data and efficiency plot in the data sheet can be applied to the equation below to determine the available power with specified operation ambient temperature.

$$P_O = (110 - T_a) / (\theta_M)(1/\eta - 1)$$

For example: 200LFM at $T_a = 80^\circ\text{C}$ for COQ with 1.0mm metal plate. The available power is $P_O = (110 - 80) / (5.65)(1/0.9 - 1) = 47.6\text{W}$, or equal to $5.0\text{V}/9.5\text{A}$ output also can be seen in the derating plot in the data sheet directly.

For the 3.0mm Sink-Plate:

The module thermal resistance θ_{S3} of COQ with 3.0mm Sink-Plate is about 30% lower compared to 1.0mm metal plate COQ module, which is listed as below:

$$\theta_{S3} = 9.13 \text{ (Free-Air)}, 5.95 \text{ (100LFM)}, 4.49 \text{ (200LFM)}, 3.40 \text{ (300LFM)}, 2.81 \text{ (400LFM)}, 2.45 \text{ (500LFM)}$$

The thermal resistance data and efficiency plot in the data sheet can be applied to the equation below to determine the available power with specified operation ambient temperature.

$$P_o = (110 - T_a) / (\theta_{S3})(1/\eta - 1)$$

For example: 200LFM at $T_a = 85^\circ\text{C}$ for COQ with 3.0mm metal plate. The available power is $P_o = (110 - 85) / (4.49)(1/0.9 - 1) = 50.01\text{W}$, or equal to 5.0V/10A output.

For the 5.0mm Sink-Plate:

The module thermal resistance θ_{S5} of COQ with 5.0mm Sink-Plate is about 50% lower compared to 1.0mm metal plate COQ module were listed as below:

$$\theta_{S5} = \begin{matrix} 7.28 \text{ (Free-Air), } 4.91 \text{ (100LFM), } 3.17 \text{ (200LFM)} \\ 2.44 \text{ (300LFM), } 2.01 \text{ (400LFM), } 1.83 \text{ (500LFM)} \end{matrix}$$

The thermal resistance data and efficiency plot in the data sheet can be applied to the equation below to determine the available power with specified operation ambient temperature.

$$P_o = (110 - T_a) / (\theta_{S5})(1/\eta - 1)$$

For example: 200LFM at $T_a = 92^\circ\text{C}$ for COQ with 5.0mm metal plate. The available power is $P_o = (110 - 93) / (3.17)(1/0.9 - 1) = 48.26\text{W}$, or equal to 5.0V/9.6A output.

Comparison

Simple comparison between module with 1.0mm metal plat, 3.0mm Sink-Plate, 5.0mm Sink-Plate and change setting for $T_c = 125^\circ\text{C}$ can be made by using COQ module shown as Plot-2.

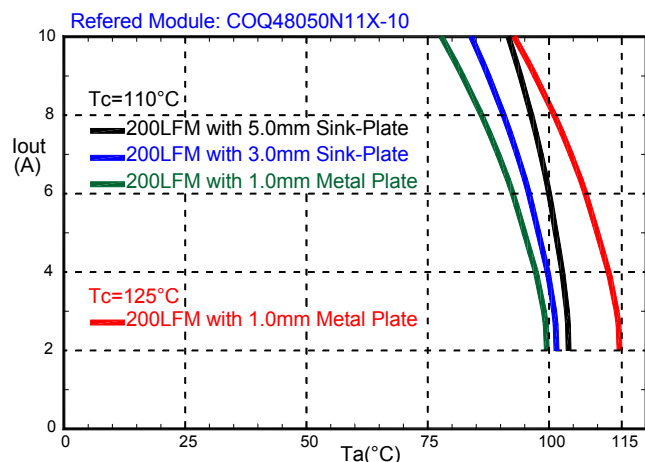

Plot-2: Comparison for $T_c = 110^\circ\text{C}$ and $T_c = 125^\circ\text{C}$

The result shows the improvement of derating performance was achieved and very closed to the result of $T_c = 125^\circ\text{C}$ by using 5.0mm Sink-Plate with no increase on the maximum allowable temperature. The 3.0mm Sink-Plate also have significant improvement for high load condition. The Sink-Plate technology has no significant improvement for the light load condition that it is limited by the fixed no load power consumption.

Conclusion

The high conversion efficiency characteristic is the basic requirement for the modern power module to achieve lowest power loss. However, the latest application is requesting for more power again with smaller package, which may cause higher module temperature. This technical challenge can be solved by two methods. One is to upper the thermal limit for safe operation, which would offer the best effect to extract the available current but pay much for safe operation life.

Another method is to reduce the module thermal resistance by adding more air contacted surface area, which would request low profile converter design with single board single component side mounting technology. It is able to cool down the module and deliver more power with no impact on the reliability and safe operation life.

Module Noise Considerations

Input Side Conducted Noise

Conductive EMC Regulations

In order to achieve a useful EMC filter circuit design, the limits of conducted emissions EN55011/FCC derived from CISPR22 was shown as below and must be well understood.

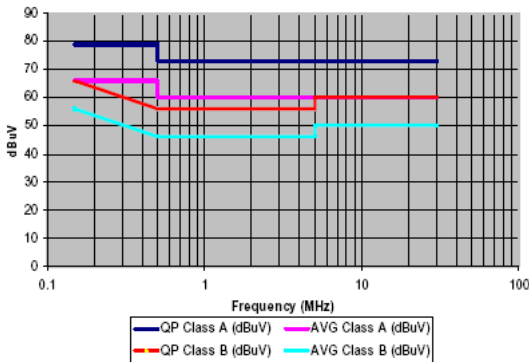

The class A and class B requirements referring to the industrial standard and the domestic standard depend on the antenna used for detecting the noise. The European standards give a higher limit for quasi-peak antenna and the lower limit for average antenna, and both limits must be met for the equipment to pass. The FCC standards used in North America have similar specifications.

Common Mode Noise

Common mode noise is one major noise source of a power module; it comes from a common-mode current that caused by fast voltage change on switching devices and coupled through capacitances between switching device and other components. The common-mode energy travels on all the lines or wires in the same direction at the same time and results in any device between the lines to perform no attenuation. However, a common mode choke or a ground choke may provide impedance between lines and ground to reduce common current. To connect capacitors between lines and ground properly would also be helpful to reduce the noise.

Differential Mode Noise

Differential-mode noise is the AC-component of input current that is caused by pulsating switching current in power stage of power module. This produces a noise voltage between the positive and negative input power terminal, which is opposite in direction or phase with respect to each other. Generally, all Glary converters have an internal π filter to differential-mode conducted noise. However, an external capacitor should be placed between input lines to reduce the noise level again to meet EMC requirement. The capacitor should be placed close to the module to minimize the loop cross-sectional area

and further reduce possible emission due to high frequency ripple current. To twist the input leads or layout a PCB power planes would also be helpful for noise cancellation and to eliminate second order coupling from near field magnetic flux radiation.

Bandwidth of EMC Components

No components are ideal for all frequency ranges. Capacitor may lose its capacitive property when the lead inductance dominates its impedance and inductor will become a capacitive element when parasitic capacitance becomes important at high frequency. The Bandwidth of EMC Components should be taking into consideration when designing an EMC filter circuit. To connect ceramic capacitor with electrolytic capacitor in parallel and connect low inductance inductor with big one could get a better bandwidth.

Referenced EMC Circuit

The referenced EMC circuit was made by verifying a 600W UH48120P20M-S50 power module that is shown as below for a reference to design a useful EMC filter fit into system. It should be noted that the circuit values might need to be modified to meet different requirements of each application.

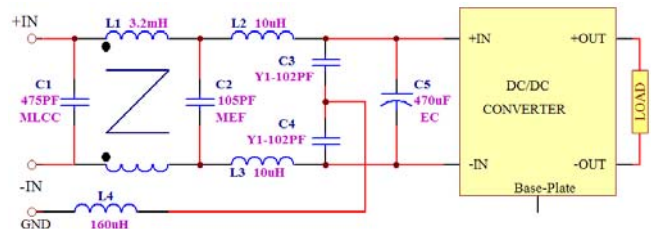

The tested curve is shown as below to demonstrate the performance of the referenced EMC filter circuit with UH48120P20M-S50 module.

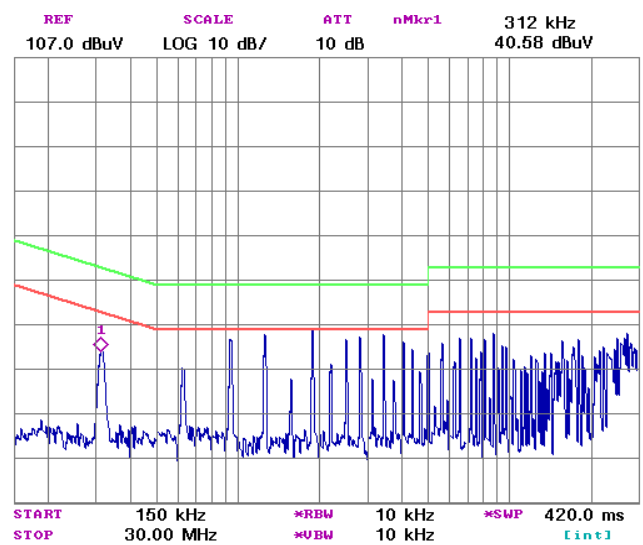

Radiated Noise

The magnetic field radiation and electric field radiation were called “near-field” radiation that decays quickly as a function of distance not usually affects the radiated measurements. However, electromagnetic radiation caused by high frequency current flow through circuit element or traces can be radiated to far distance, it can be minimized by proper board layout to keep all leads with AC current short circuit, twisted or run as ground planes to minimize loop cross-sectional area would be greatly helpful. Glary has six-side metal package option for several product series and could provide extra RFI shielding performance for critical application. It should be noted that in many cases if the device fails in the common mode current test, it will also fail in the radiated-emission test since the lines would carry common mode noise and perform as an antenna to emit radiated noise.

Output Side Ripple/Noise

The output ripple/noise performance can be improved by adding more low-ESR external capacitors closed to output terminals. The reference trace layout that should provide corrective measuring capability and improve output ripple/noise performance is show as below.

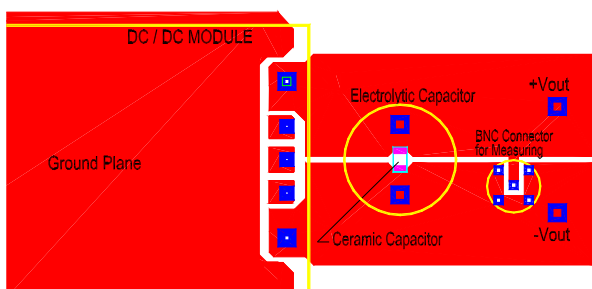

General Application Information

Storage/Handling

Module Storage

It is user's liability to avoid module being overexposure to moisture during storage; board mount assembly and board rework. A below 30°C temperature 85%RH storage condition is acceptable for on production line 24 hours storage maximum to avoid possible risk from wave soldering process.

The solder terminal plating material of Glary module is gold metal, which can meet MSL1 level requirement for long-term storage. However, the module must go through a de-moisture process by being placed into a chamber of 85°C for 12 hours before use, to prevent the module from risk of explosion caused by heated moisture during soldering process. The recommended module storage condition is 30°C-60%RH.

Module Handling

The user must take responsibility during storage, board mount assembly and board rework to avoid module over stress due to drop, impact or any kind of tools touch to its surface and components. The user should also prevent the module from the damage of electrostatic discharge. Except for activities following the application notes herein stated, any extra direct work without consulting and/or consensus with Glary, including but not limit to cutting pins, adding or removing potting compound or glues or enclosures, unauthorized electrical and/or mechanical analysis, would result in waiver of Glary's service and warranty liabilities whatsoever.

Soldering

Hand Soldering

Hand soldering is the preferred method for Glary module due to the variability of the amount of solder applied, the time the soldering iron is held on the joint, the temperature of the iron, and the temperature of the solder joint. A temperature-controlled 70W solder iron with 0.125" tip and 425°C setting is suitable for terminal soldering work. The soldering time is 3S~6S for 0.04" terminal pin diameter, 5S~10S for 0.06" terminal pin diameter and 8S~16S for 0.08" terminal pin diameter.

These guidelines above may require modification to optimize the soldering time for your particular circuit board or soldering iron. The exact soldering time and temperature for your specific application can be determined by mounting a thermocouple to the power module terminal using high-temperature solder. The minimum soldering time is defined as the time required for the terminal to reach 125°C. The maximum

soldering time is the time required for the terminal to reach 165°C. The power module's internal temperature must stay below the storage temperature of 183°C or at least less than the critical continuous temperature of 183°C.

Wave Soldering

Glary understands that wave soldering is the most popular soldering method for the solder attachment of through-hole component leads for mass volume productions. Glary power modules are designed to be compatible with single-wave, dual-wave or turbid-wave soldering machines. The suggested soldering process is to keep the power module's internal temperature below 183°C. The typical recommended preheat temperature range is between 90°C and 105°C on the module-side of the circuit board. The pin-side of circuit board preheat temperature is recommended to be greater than 120°C, and preferable within 100°C of the solder-wave temperature, a maximum preheat rate of 4°C/s of the solder-wave temperature, a maximum preheat rate of 4°C/s is suggested. The maximum recommended solder pot temperature is 250°C with a typical solder-wave dwell time of 3 seconds or up to 6 seconds maximum.

Cleaning/Drying

Cleaning

Post solder cleaning is usually the final process of circuit board assembly prior to electrical-board testing. The result of inadequate circuit board cleaning can affect both the reliability of a power module and the testability of the finished circuit-board assembly. Glary power modules are compatible with most cleaning processes but the cleaning materials should be chosen to be compatible with plastic parts or potted material inside the module. Incompatible cleaning material may cause malfunction or reduce its long-term operation reliability.

Drying

The drying process should be equipped with blowers capable of generating 1000CFM of air or above so that the amount of rinse water left to be dried off with heat is minimal. Handheld air guns are not recommended due to the variability and non-consistency of the operation. For open-frame power module constructions with magnetic structures (transformers

and inductors) that have un-potted windings or cavities, a heating process of 100°C-0.5 hours inside the chamber is recommended for the assembly to ensure that the moisture and other potential foreign contaminants are driven out from the open windings and cavities to ensure that no residues would affect long-term reliability and isolation voltage.

Pad Layout

The pad layout of Glary power module depends on its current rating. The low current model just requires a simple through hole to carry load current. However, the large current models would introduce high I²R loss at the solder point, which may cause over heating effect and further reduce the reliability. The pad layout for high current terminal pins becomes the most important consideration of the circuit board design.

Through Hole Size

For the 0.04" (1.0mm) terminal pins:

Use the 0.05" 1.25mm diameter plated through hole with minimum 0.08" (2.0mm) diameter solder pad for all modules layout.

For the 0.06" (1.5mm) terminal pins:

Use the 0.075" (1.80mm) diameter plated through hole with minimum 0.12" (3.0mm) diameter solder pad for the low current circuit board layout. Based on the layout described above, it is necessary to have 4pcs~8pcs 0.5mm diameter of current distribution via to surround each through hole for reducing the current density and I²R loss while the current is high. The optional double pin layout will be necessary when ultra high current module was used.

For the 0.08" (2.0mm) terminal pins:

Low Current Module: use the 0.10" (2.54mm) diameter plated through hole with minimum 0.16" (4.0mm) diameter solder pad for the circuit board layout.

High Current Module: use the 0.10" (2.54mm) diameter plated through hole with minimum 0.16" (4.0mm) diameter solder pad for the circuit board layout. It is necessary to have 5pcs~10pcs 0.5mm diameter of current distribution via to surround each through hole to reduce the current density and I²R loss. The optional double pin layout will be necessary when ultra high current module was used.

Parallel connection / operations and current share application note

Overview

This document will examine method for active load sharing, basic criteria and performances of such a function on Glary UH and PS module series.

This application note provides also a brief summary about some general guidelines to help accomplishing the task.

System requirements and premises

The basic requirements of a power supply system, consisting of a number of paralleled sources, to increase the total load current are:

- to maintain a regulated output voltage under variations in line or load;
- to control the output current of each supply just to share the total load current equally;

To maximize reliability of the system there are the following features:

- Achieve redundancy, so that a failure of any one supply can be tolerated as long as there is sufficient current capacity available from the remaining power units;
- Implement a load sharing method without any external control system.

In addition, these are the following desirable features:

- to have a common, low bandwidth share bus interconnecting all power units;
- to achieve good load sharing transient response;
- the ability to margin the system output voltage with one control.

In other words, the combination of power supplies behaves like one large supply with equal stress on each of the units. Also, reliability can be better secured by taking advantage of load sharing to incorporate modular redundancy.

Load sharing techniques

There are a number of schemes to achieve load sharing.

Six methods are possible: the following method is passive method while all the rest are active methods.

O-ring diode method

This is the most passive common method of paralleling power modules by using an O-Ring diode on each unit. By using power modules with adjustable outputs, it is possible to 'Balance' the current sharing of the units. By taking a 'differential' voltage measurement at the anodes of the O-Ring diodes current will be shared more equally the closer the differential voltage is to zero. This method has the disadvantage of an additional power loss in the diodes and dissipation of the heat generated in the diodes.

The droop method

The Droop method programs the output impedance of the power supplies to achieve load sharing. It is a simple open loop method, but is not accurate.

The dedicated master

This approach is to select a master module to perform the voltage control and force the remaining modules (slaves) to act as current sources. A dedicated Master approach with current mode supplies will facilitate current sharing but it does not achieve redundancy.

External controller

This method is to use an external controller to perform the load sharing. This is achieved by comparing all loads sharing signals from the individual power units and adjusts the corresponding feedback signal to balance the load currents. This system does perform well but requires an additional controller and multiple connections between the controller and each supply.

Automatic current sharing – average current method

For automatic current sharing no external controller is required and a single share bus interconnects all the supplies. This requires an adjustment amplifier that compares a current signal from the share bus to the individual units current and adjusts the reference of the voltage amp until equal load current distribution is achieved.

The average Current method is a patented technique where each power module's current monitor drives a common share bus via a resistor. While this scheme performs accurate current sharing, it can result in a specific application problem. An example is when a supply runs into current limit, causing the share bus to be loaded down and the output voltage to regulate to the lower adjust limit. A similar failure mode will exist if the share bus is shorted or if any unit on the share bus is inoperative.

Automatic current sharing – highest current method

This technique for automatic current sharing shown compares the highest current module to each individual current, and adjusts the reference voltage accordingly to correct the imbalance of load current.

This technique is similar to the average current method except that the resistor is replaced with a diode, allowing only one unit to communicate on the share bus. This method provides for excellent sharing among the slaves with an error in the master's load current contribution because of the diode.

Internal IC Load Share Regulator has improved this function by replacing the diode with a unidirectional buffer to reduce the master's error. An inoperative or insufficient capacity supply will not effect the sharing of the operational units.

A shorted share bus will disable the reference adjustment section used for load sharing, making the units operate as stand-alone.

A generic load share system with the basic bus connections required performing accurate output voltage control and load sharing is shown in Fig 1. The output voltage is sensed with a fully differential, high-impedance voltage amplifier.

Each individual power supply current is sensed with a differential current amplifier, and it is used for the load share portion of the circuit.

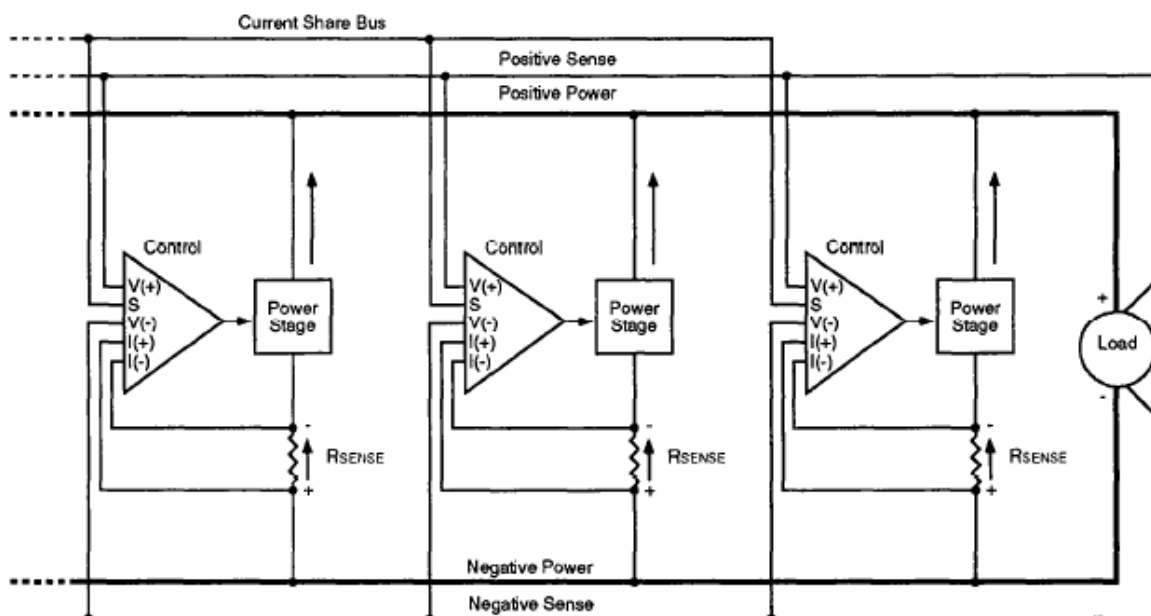

Fig. 1. Basic bus connections required performing accurate output voltage control and load sharing

The share bus signal interconnecting all the paralleled modules is a low-impedance, noise insensitive line. The connection diagram is shown in FIG 2. The following discussion of the voltage and current sharing loops should help the user to understand the operation and features of this technique.

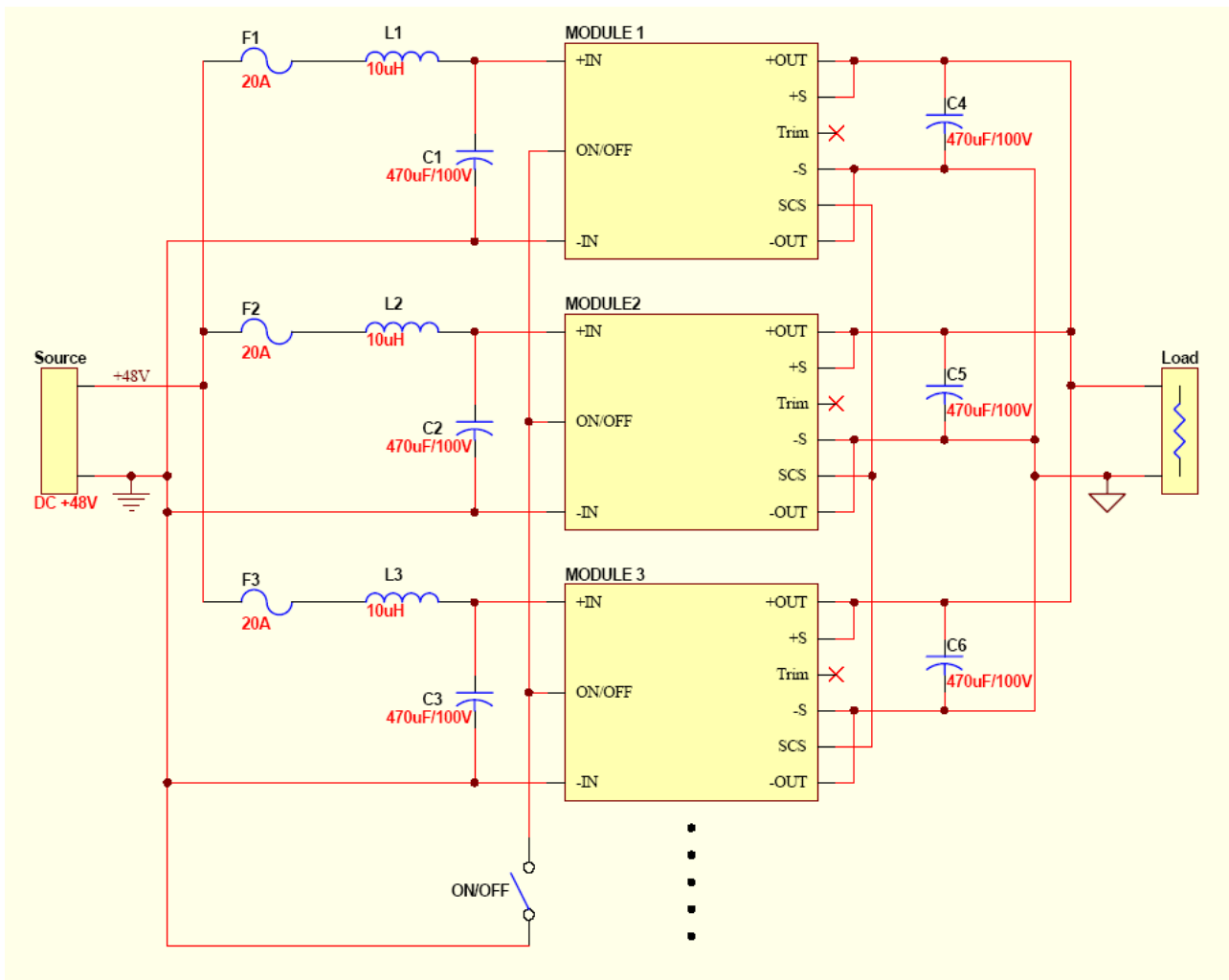

Fig. 2. System connections for modules with independent load sharing

External design basic criteria, design rules, suggestions and reached performances

Layout considerations

It is quite imperative to adopt a symmetrical and “star node” layout of the power circuit with minimum loop area and impedance for each PCB track between modules and load. This basic criterion is also to avoid loop noise generation.

Basic connection diagram to be followed is shown on Fig. 2.

When using units connected in parallel, best suggestion is to not connect **sense pins** unless load is far away from output pin's module; basic criteria to decide about this issue is related to voltage drop across PCB tracks that is suggested to be less than 0,5% of the output voltage; just in case output voltage drop is higher than what is suggested, sense pins can be conveniently connected to load as shown on Fig. 2

Important issue is: **do not connect trim pins and circuitry** when parallel configuration is adopted in order to not defeat parallel performances.

Electrical ratings and thermal suggestions of power modules connected in parallel

All modules connected in parallel are suggested to be mounted on the same heat sink in order to achieve the best possible thermal coupling. It is the best to space the modules apart over the whole surface of the heat sink to avoid creation of hot spots on the heat sink and to minimize heat density.

The current rating of the whole assembly must not exceed 80% to 90% of the total current capability of the modules just to compensate for unavoidable parameter variations between the modules.

Modules must have very symmetrical designs with very short connections both for power and control terminals. Parasitic resistance of connections has to be very low in order to facilitate a parallel module layout with minimum loop impedance.

Additional external components

External delayed fuse type is suggested to be connected on each output DC/DC lines as close as possible to output pins. This suggested solution is to prevent any burns on the system just in case one module goes on hypothetical short circuit failure and so may sink all the current of the entire system. Alternative or equivalent solution to fuse is OK.

A suggested alternative active solution can be implemented by using the Linear Technology IC LTC4357 (Positive High Voltage Ideal Diode Controller) driving N-channel MOSFETs placed in parallel as substitution of above fuse.

This simple solution enhances system reliability and prevents hazard situations.

The suggested best current trip value of fuse could be around 160% of the maximum output current of each module.

General considerations

Paralleling of power modules with good current sharing can be achieved by following some important guidelines. The above recommendations and greater care and maximum precautions are necessary if the number of paralleled modules increases and become very high.

Theoretically speaking the **maximum number of paralleled modules limitation does not exist; however the maximum quantity suggested is over 16-18 pieces**; the only precaution that is necessary to adopt is a safe and reliable design for the entire system and particular attention to electrical power point of view.

Overall electrical Performances for parallel

-Current share tolerance: **+/-5%**

-Voltage tolerance with current share: **+/-1%**

IMPORTANT NOTICE

Glary Power Technology (GLARY) reserves the right to make changes to its products or to discontinue any product or service without notice, and advise customers to obtain the latest version of relevant information to verify, before placing orders, that information being relied on is current and complete. All products are sold subject to the terms and conditions of sale supplied at the time of order acknowledgement, including those pertaining to warranty.

CERTAIN APPLICATIONS, LIKE PRESENT ONE, ARE DELICATE AND SYSTEM DESIGN LEADS TOTALLY THE SAFETY AND THE RELIABILITY OF ENTIRE APPLICATION.

In order to minimize risks associated with the customer's applications, adequate design and operating safeguards must be provided by the customer to minimize inherent or procedural hazards.

Glary assumes no liability for applications assistance or customer product design. Glary does not warrant or represent that any license, either express or implied, is granted under any patent right, copyright, mask work right, or other intellectual property right of Glary covering or relating to any combination, machine, or process in which Glary products or services might be or are used.

2012 New Products

U64 Nano Brick

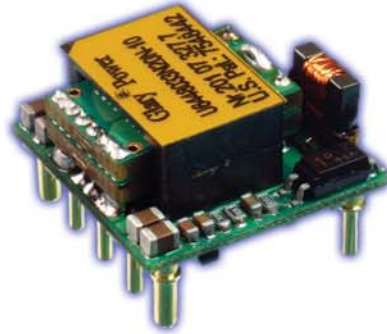

30W~40W
0.71" X 0.71"
93% Efficiency

U32 Micro Brick



60W~75W
0.91" X 0.91"
94% Efficiency

BQ 1/4 Brick

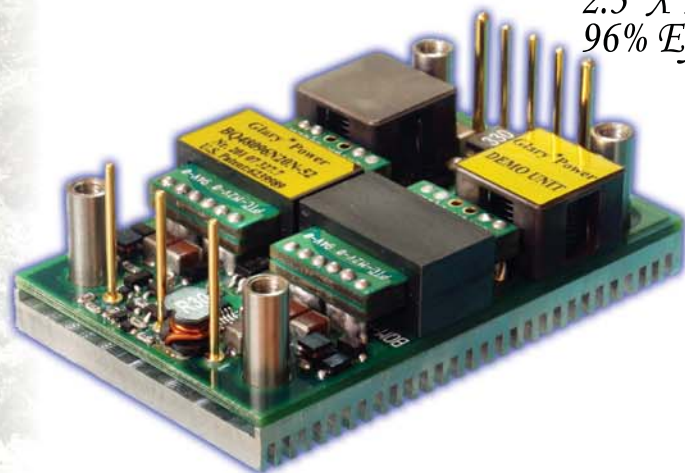

400W~600W
2.3" X 1.45"
96% Efficiency