

CPQ48S050-50

- High efficiency 92%@5.0V/30A
..... 92%@5.0V/40A
..... 91%@5.0V/50A
- High useable current50A at 55°C 200LFM
.....50A at 70°C 300LFM
.....50A at 75°C 400LFM
- High power density214W/in³
- Low profile 0.35"(9.0mm)
- Standard footprint 2.30"×1.45"
- Operation temperature -40°C~120°C
- Quarter Brick Pin Out Compatible
- Open Frame Package

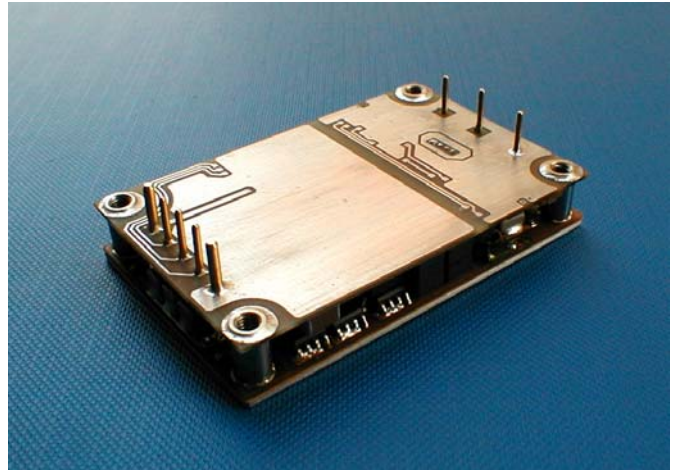

The "Cool" series **CPQ48S050-50** quarter brick size high efficiency dc/dc converter provides 250 watts power or 50A current with industry standard compatible pin assignments. 214W/in³ power density, 0.35" converter profile and 91% efficiency allow a system designer remove the heat sink to save the space in all dimensions. The efficient SR technology combining with patented "Buck Reset" topology reduce total power loss; creative design technology and highly thermal conductivity IMS base-plate eliminate the hot spot gives converter good thermal performance. Highly conversion efficiency with reduced component count circuit design result in good reliability.

This module is designed as a bus converter to provide a tightly regulated 5.0V output for Intermediate Bus Architecture (IBA) across 36~75V wide range input for powering multiple low cost, non-isolated, point-of-load regulators. The module is suited ideally for telecommunication, computer servers, enterprise networking equipment and other applications that use a 48V or 36~75V input bus. Open frame package enhance the thermal performance with low speed airflow and lower the mass of converter to reduce vibration and shock problems greatly. Option of remote control logic is also available for different control signal.

SPECIFICATIONS

ENVIRONMENTAL SPECIFICATIONS

Temperature	Operation	-40°C to +120°C
	Storage	-55°C to +125°C
Altitude	Operation	15000 feet max
	Storage	50000 feet max

GENERAL SPECIFICATIONS

Efficiency	Typical	See table
Frequency	Typical	300KHz
Isolation	In/Case	1000V
	In/Out	2000V
	Out/Case	1000V
MTBF	Bellcore	3.45×10 ⁶ hrs @GB.
OTP	Internal	120°C
Weight		1.45 oz
Size		2.30"×1.45"×0.35"

INPUT SPECIFICATIONS

Input voltage		See table
Ripple current	See note 1	5% I _{in (nom)}
UVLO	Start up	97% V _{in (min)}
	Shut down	92% V _{in (min)}
Remote control	Logic High	3V to +V _{in}
	Logic Low	0V to 1V

OUTPUT SPECIFICATIONS

Voltage accuracy	Typical	±1%
Line regulation		±0.2%
Load regulation	10%~100%	±0.2%
Ripple & noise	20MHz BW	2% V _{o (RMS)}
Temperature drift		±0.02%/°C
Current limits		110%~125%
Voltage trim		±10%

CPQ48S050-50

CONVERSION PARAMETERS

INPUT		OUTPUT		EFF.	PART NUMBER*
36V~75V	275W	250W	5.0V-50A	91%	CPQ48S050-50ABC

* When ordering Glary converters, please ensure that you use the complete ordering code.

* Options for **CPQ48S050-50ABC** are as follows:

- A (Enable Logic): "P" for Positive "N" for Negative.
- B (Output Pin Size): "S" for 1.5mm "L" for 2.0mm.
- C (Pin Dimension): "0" for pin length 0.110", "1" for pin length 0.145"
"2" for pin length 0.180", "3" for pin length 0.250"

Example: **CPQ48S050-50NS3** is a "Cool" series **POWERFUL** version quarter brick size 48V to 5.0V/50A dc/dc converter with options of negative control logic, 1.5mm pin diameter and 0.250" pin length.

DRAWINGS

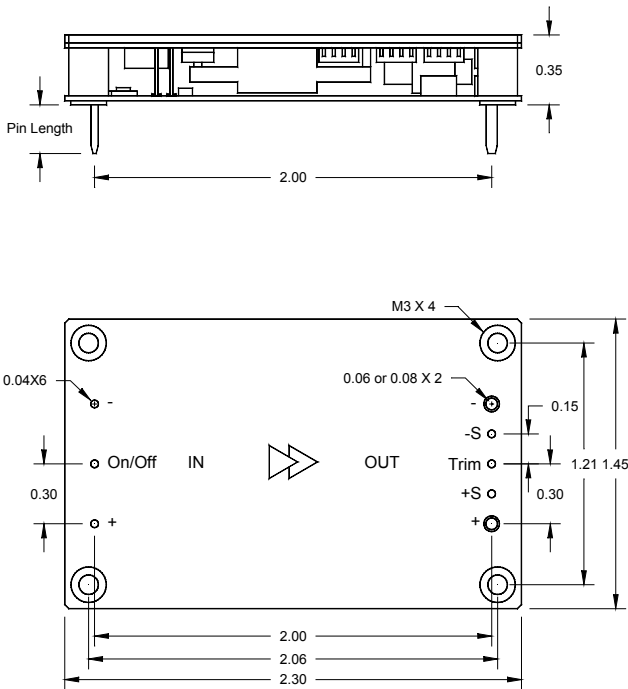

1. Unit: inch
2. Materials: Aluminum & Plastic
3. Tolerance: +/-0.01"

PERFORMANCE

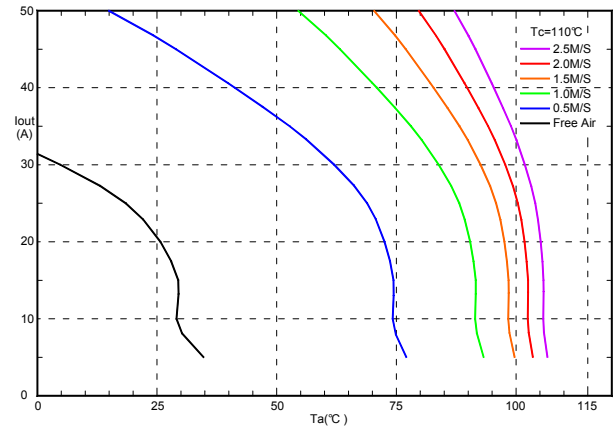

Out Put Current Derating Curves with 0.14" Heat Sink (Horizontal)

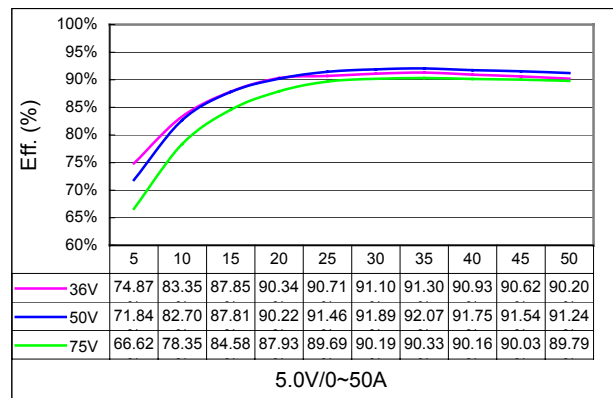

Efficiency Change by Output Current

NOTE

1. 20MHz bandwidth current probe measured without an external filter.
2. Output ripple and noise is measured by using the proposed test method of Glary Power Technology Co. Ltd.
3. Input fusing is required and recommended to base on surge current and maximum input current.
4. Case and base-plate should be connected to AC ground to maintain good EMC performance.
5. Case and base-plate should be inaccessible to prevent the damage from highly operating temperature.
6. Contact Glary Power Technology for non-standard inquiry.